

# IM481H Plus

High performance ultra-miniature microstepping driver



Change Log		
Date	Revision	Change Summary
03/09/2006	R030906	Change Temperature Spec to -40 to +85 deg. C, Changed Quiescent current spec from 40 to 150mA, max step clock rate from 10Mhz to 5 MHz, Step clock response time from 100 to 650nS, MSEL setup time from 100 nS to 4 mS, zero crossing response from 75 to 650 nS.
03/22/2006	R032206	Added notes concerning Fault condition on power up or reset and 150mA quiescent current
04/052007	R040507	Changed 5 Mhz step clock to 2.5 MHz max. Added Appendix B: INT-481, Appendix C: Cabling and Appendix D: Sample Applications. Major updates throughout. Changed layout to reflect current Novanta IMS documentation styles and standards.
01/17/2008	R011708	Minor updates and corrections throughout.
04/01/2010	R041010	Changes to warranty, disclaimer conditions for use and address information
12/18/2019	R121819	Correction to the Input Pull-up Resistor graphic
06/01/2023	R060123	Rebrand to Novanta IMS

The information in Novanta IMS product manuals and on this web site has been carefully checked and is believed to be accurate; however, no responsibility is assumed for inaccuracies.

Novanta IMS reserves the right to make changes without further notice to any products to improve reliability, function or design. Novanta IMS does not assume any liability arising out of the application or use of any product or circuit described; neither does it convey any license under its patent rights of others.

Novanta IMS's general policy does not recommend the use of its products in life support or aircraft applications wherein a failure or malfunction of the product may directly threaten life or injury. Per Novanta IMS's terms and conditions of sales, the user of Novanta IMS products in life support or aircraft applications assumes all risks of such use and indemnifies Novanta IMS against all damages.

## Important information

The drive systems described here are products for general use that conform to the state of the art in technology and are designed to prevent any dangers. However, drives and drive controllers that are not specifically designed for safety functions are not approved for applications where the functioning of the drive could endanger persons. The possibility of unexpected or un-braked movements can never be totally excluded without additional safety equipment. For this reason personnel must never be in the danger zone of the drives unless additional suitable safety equipment prevents any personal danger. This applies to operation of the machine during production and also to all service and maintenance work on drives and the machine. The machine design must ensure personal safety. Suitable measures for prevention of property damage are also required.

## Qualification of personnel

Only technicians who are familiar with and understand the contents of this manual and the other relevant documentation are authorized to work on and with this drive system. The technicians must be able to detect potential dangers that may be caused by setting parameters, changing parameter values and generally by the operation of mechanical, electrical and electronic equipment.

The technicians must have sufficient technical training, knowledge and experience to recognise and avoid dangers.

The technicians must be familiar with the relevant standards, regulations and safety regulations that must be observed when working on the drive system.

## Intended Use

The drive systems described here are products for general use that conform to the state of the art in technology and are designed to prevent any dangers. However, drives and drive controllers that are not specifically designed for safety functions are not approved for applications where the functioning of the drive could endanger persons. The possibility of unexpected or unbraked movements can never be totally excluded without additional safety equipment.

For this reason personnel must never be in the danger zone of the drives unless additional suitable safety equipment prevents any personal danger. This applies to operation of the machine during production and also to all service and maintenance work on drives and the machine. The machine design must ensure personal safety. Suitable measures for prevention of property damage are also required.

In all cases the applicable safety regulations and the specified operating conditions, such as environmental conditions and specified technical data, must be observed.

The drive system must not be commissioned and operated until completion of installation in accordance with the EMC regulations and the specifications in this manual. To prevent personal injury and damage to property damaged drive systems must not be installed or operated.

Changes and modifications of the drive systems are not permitted and if made all no warranty and liability will be accepted.

The drive system must be operated only with the specified wiring and approved accessories. In general, use only original accessories and spare parts.

The drive systems must not be operated in an environment subject to explosion hazard (ex area).

This page intentionally left blank

# Contents

<b>Section 1: Introduction</b> .....	<b>1</b>
The IM481H Plus Hybrid .....	1
Features and Benefits .....	1
IM481H Plus .....	1
The Product Manual .....	2
Symbols Used In This Document .....	2
Notes and Warnings .....	2
<b>Section 2: Hardware Specifications</b> .....	<b>3</b>
Section Overview .....	3
Mechanical Specifications .....	3
Thermal Specifications .....	3
Electrical Specifications .....	4
Pin Assignment and Description .....	5
Options/Accessories .....	6
<b>Section 3: Mounting the IM481H Plus</b> .....	<b>7</b>
Section Overview .....	7
Mounting the IM481H Plus Using the Optional H-481 Heat Sink .....	8
Mounting the IM481H Plus Using the Optional INT-481 Interface Board .....	9
<b>Section 4: Power Supply Requirements</b> .....	<b>10</b>
Section Overview .....	10
Selecting a Power Supply .....	10
Selecting a Motor Supply (+V) .....	10
Recommended Novanta IMS Power Supplies .....	11
Recommended Wiring .....	12
Rules of Wiring and Shielding .....	12
AC Line Filtering .....	12
<b>Section 5: Motor Requirements</b> .....	<b>13</b>
Section Overview .....	13
Selecting a Motor .....	13
Types and Construction of Stepping Motors .....	13
Sizing a Motor for Your System .....	13
Connecting the Motor .....	15
Pins .....	15
8 Lead Motors .....	15
6 Lead Motors .....	16
4 Lead Motors .....	16
<b>Section 6: Interfacing to the IM481H Plus</b> .....	<b>17</b>
Section Overview .....	17
Layout and Interface Guidelines .....	17
Motor Power .....	17
+5 VDC Input .....	17
Controlling The Output Current Using the Current Adjustment Input .....	18
Setting the Output Current .....	19
Interfacing the IM481H Plus Inputs .....	22
Input Timing .....	22
Interfacing the Fault and Reset Inputs .....	23
Step Clock and Direction .....	24
Interfacing the IM481H Plus Outputs .....	24
Fullstep Output Signal .....	24
Fault Output .....	24
Minimum Connections .....	25

## Appendices

<b>Appendix A: Troubleshooting</b> .....	<b>A-1</b>
Section Overview .....	A-1
Basic Troubleshooting .....	A-1
Common Problems and Solutions .....	A-1
Symptom: Motor does not move. ....	A-1
Symptom: Motor moves in the wrong direction.....	A-1
Symptom: Unit in fault.....	A-1
Symptom: Erratic motor motion. ....	A-2
Symptom: Motor stalls during acceleration. ....	A-2
Symptom: Excessive motor and driver heating. ....	A-2
Symptom: Inadequate holding torque. ....	A-2
Contacting Application Support .....	A-2
Returning Your Product to Novanta IMS .....	A-2
<b>Appendix B: The INT481H Interface Board</b> .....	<b>A-3</b>
Section Overview .....	A-3
Electrical Specifications .....	A-3
Mechanical Specifications .....	A-3
Pin Assignment and Description .....	A-4
Mounting the INT-481 Interface Board .....	A-5
Recommended Wiring .....	A-6
Rules of Wiring and Shielding .....	A-6
Configuration and Interface .....	A-7
Output Current Adjust/Current Reduction .....	A-7
Optically Isolated Inputs .....	A-7
LED Indicators .....	A-9
Fault Protection .....	A-10
Full Step Output .....	A-10
Microstep Resolution Selection .....	A-10
Minimum Required Connections .....	A-11
<b>Appendix C: Recommended Cable Configurations</b> .....	<b>A-12</b>
<b>Appendix D: Application and Usage Examples</b> .....	<b>A-17</b>
Electronic "Gear Shifting" .....	A-17
Using The Full Step Output to Show Axis Position .....	A-18

## List of Figures

Figure 2.1: IM481H Plus Dimensions .....	3
Figure 2.2: Step and Direction Timing Diagram .....	4
Figure 2.3: IM481H Plus Pinout .....	6
Figure 3.1: PCB Hole Pattern (Direct Mounting of the IM481H Plus to a PC Board) .....	7
Figure 4.1: H-481 Heat Sink Kit .....	8
Figure 4.2: IM481H Plus Heat Sink Mounting .....	8
Figure 4.3: IM481H Plus Panel Mount with Heat Sink .....	9
Figure 4.4: IM481H Plus Panel Mount without Heat Sink .....	9
Figure 5.1 A & B: Per Phase Winding Inductance .....	14
Figure 5.2: 8 Lead Series Motor Connections .....	15
Figure 5.3: 8 Lead Parallel Motor Connections.....	15
Figure 5.4: 6 Lead Half Coil (Higher Speed) Motor Connections .....	16
Figure 5.5: 6 Lead Full Coil (Higher Torque) Motor .....	16
Figure 5.6: 4 Lead Motor Connections .....	16
Figure 6.1: +5 VDC Power Supply Connection .....	18
Figure 6.2: Current Adjust Resistor .....	20
Figure 6.3: Current Adjust Voltage .....	20
Figure 6.4: Current Reduction Adjustment Resistor Connection .....	21
Figure 6.5: Interfacing the Current Reduction Input .....	21
Figure 6.6: Input Pull-Up Resistors .....	22
Figure 6.7: MSEL Inputs, Interface Example .....	22
Figure 6.8: Reset Timing .....	23
Figure 6.9: Interfacing the Fault In/Reset Inputs .....	23
Figure 6.10: Multiple Drives - One Reset .....	23
Figure 6.11: Step and Direction Timing Diagram .....	24
Figure 6.12: Minimum Connections .....	25

## Appendices

Figure B.1: INT481H .....	A-3
Figure B.2: INT-481H Mechanical Specifications .....	A-3
Figure B.3: IM481H Plus Panel Mount with Heat Sink .....	A-5
Figure B.4: IM481H Plus Panel Mount without Heat Sink .....	A-5
Figure B.5: INT-481H Current Adjust and Reduction Resistor Connection .....	A-7
Figure B.6: INT-481H Optically Isolated Inputs.....	A-8
Figure B.7: Jumper JP1 and JP2 Placement and Orientation. ....	A-9
Figure B.8: Power and Fault LED Indicators. ....	A-9
Figure B.9: Microstep Resolution Select Switch .....	A-11
Figure B.10: Minimum Required Connections .....	A-11
Figure C.1: DC Cabling Under 50 Feet.....	A-12
Figure C.2: Cabling 50 Feet or Greater, AC Power to Full Wave Bridge .....	A-13
Figure C.3: Cabling 50 Feet or Greater, AC Power to Motor Power Supply .....	A-14
Figure C.4: Cabling Under 50 Feet, Novanta IMS Driver to Motor .....	A-15
Figure C.5: Cabling Under 50 Feet, Novanta IMS Driver to Motor .....	A-16
Figure D.1: Electronic Gear Shifting Application Example .....	A-17
Figure D.2: On-Full-Step Position Counter.....	A-18

## List of Tables

Table 2.1: IM481H Plus DC Electrical Characteristics.....	4
Table 2.2: Pin Assignment and Description.....	5
Table 3.1: H-481 Heat Sink Mounting Hardware.....	9
Table 4.2: +5VDC Power Supply Specifications.....	11
Table 4.1: Motor Power Supply Specifications.....	11
Table 6.1: Current Adjust Reference/Output Current.....	20
Table 6.2: Microstep Resolution Select Settings.....	23

## Appendices

Table B.1: INT-481H Electrical Specifications.....	A-3
Table B.2: Pin Assignment and Description.....	A-4
Table B.3: H-481 Heat Sink Mounting Hardware.....	A-5
Table B.4: Microstep Resolution Switch Settings.....	A-10
Table C.1: Driver Supply Cable Wire Size.....	A-14
Table C.2: Driver Supply Cable Wire Size.....	A-16

# Section 1

---

## Introduction

### The IM481H Plus Hybrid

The IM481H Plus is a high performance, yet low cost microstepping driver that utilizes advanced hybrid technology to greatly reduce size without sacrificing features. The IM481H Plus is exceptionally small, easy to interface and use, yet powerful enough to handle the most demanding applications.

The IM481H Plus has 16 built-in microstep resolutions. The resolution can be changed at any time without the need to reset the driver. This feature allows the user to rapidly move long distances, yet precisely position the motor at the end of travel without the expense of high performance controllers.

With the development of proprietary and patented circuits, ripple current has been minimized to reduce motor heat-ing common with other designs, allowing the use of low inductance motors improving high speed performance and system efficiency.

The IM481H Plus, because of its microstep resolution and superior current control, can be used to increase accuracy and smoothness in systems using higher step angle motors. In many instances mechanical gearing can be replaced with microstepping, reducing cost and eliminating potential maintenance.

**OPTIONAL HEAT SINK KIT:** The H-481 provides effective thermal protection for the IM481H Plus Driver. The extruded aluminum heat sink is designed for direct PCB mounting and is supplied with assembly hardware.

**OPTIONAL INTERFACE BOARD:** The INT-481 is a plug-on interface board which can be used with the IM481H Plus to facilitate testing and prototype development, or in situations where panel mounting is preferred.

The INT-481 contains extra circuitry which includes: Optical isolators for step clock, direction, enable and reset, along with extra fault detection circuits, +5VDC supply, input capacitor, and fault and power LEDs. Wiring is done through a 15 pin screw terminal header. A four position dip switch is supplied for microstep resolution selection.

### Features and Benefits

#### *IM481H Plus*

- Very Low Cost
- Ultra Miniature 1.1" x 2.7" x 0.17"
- High Input Voltage (+12 to +48VDC)
- High Output Current (1.5 Amps RMS, 2.1 Amps Peak)
- Advanced Hybrid Design
- Replaces Mechanical Gearing for Smoothness and Positioning
- Designed for High Performance, Low Inductance Stepping Motors
- 20 kHz - 60 kHz Chopping Rate
- Up to 5 MHz Step Clock Rate
- 16 Selectable Microstepping Resolutions that can be Changed On-The-Fly
- Up to 51,200 Steps/Rev with a 1.8° Motor
- At Full Step Output
- Active Resonance Reduction Circuitry
- Enhanced Current Control to Increase Motor Smoothness

## The Product Manual

The IM481H Plus product manual in its electronic format may be downloaded from the Novanta IMS website at <https://novantaims.com>. This version includes a Bookmarks feature that allows the reader to link from a Book marked Topic in the Table of Contents to a full description of that feature's attributes and functions.

## Symbols Used In This Document



ESD Warning: Components sensitive to Electrostatic Discharge.



Hazardous Voltage Warning: Motion systems may contain dangerous voltage levels.



Product Usage Warning: Failure to heed warnings marked with this symbol may result in damage to the device and/or system components.



Note: Indicates a usage tip for your Novanta IMS Product.



Math: Indicates an equation to be used in configuring your Novanta IMS product.

## Notes and Warnings



WARNING! The IM481H Plus components are sensitive to Electrostatic Discharge (ESD). All handling should be done at an ESD protected workstation.



WARNING! Hazardous voltage levels may be present if using an open frame power supply to power the IM481H Plus.



WARNING! Ensure that the power supply output voltage does not exceed the maximum input voltage of the IM481H Plus.

WARNING! Do not apply power to the IM481H Plus without proper heat sinking or cooling! The included thermal pad (TI-481) MUST be used between the IM481H Plus and the heat sink! The maximum rear plate temperature of the IM481H Plus is 70°C!

# Section 2

## Hardware Specifications

### Section Overview

This section will acquaint you with the dimensional information, pin description, power, environmental and thermal requirements of the IM481H Plus. It is broken down as follows:

- Mechanical Specifications.
- Electrical Specifications.
- Thermal Specifications.
- Pin Assignment and Description.

### Mechanical Specifications

#### Dimensional Information

Dimensions are in inches, parenthesis dimensions are in millimeters. Weight: 0.512 oz./14.6 gm

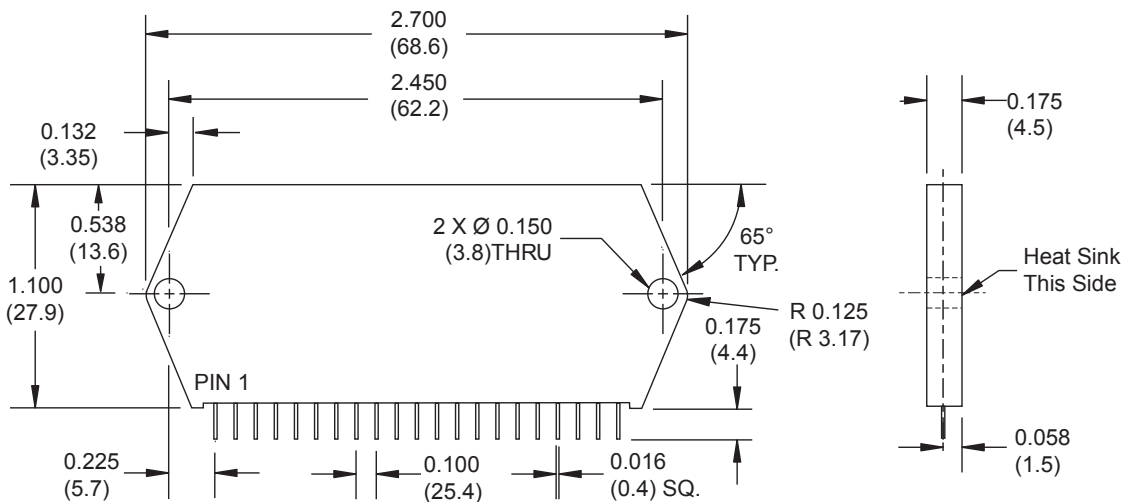

Figure 2.1: IM481H Plus Dimensions

**N** NOTE: An optional Heatsink (Part # H-481) is available for the IM481H Plus.

### Thermal Specifications

Storage Temperature .....	-40° to +125°C
*Operating Temperature.....	-40° to +85°C ±3°
‡Rear Mounting Surface (Max).....	+70°C

\*As measured on the thermal transfer surface of the device

‡Additional cooling may be required to limit rear mounting surface.

Care should be taken when choosing a heat sink to ensure that there is good thermal flow, otherwise hot spots may occur in the IM481H Plus which will reduce the effectiveness of the thermal protection.

An optional Heat Sink (Part # H-481) is available for the IM481H Plus. Thermal Pad (Part # TI-481) is supplied with each IM481H Plus.

**!** WARNING! Do not apply power to the IM481H Plus without proper heat sinking or cooling! The included thermal pad (TI-481) **MUST** be used between the IM481H Plus and the heat sink! The maximum rear plate temperature of the IM481H Plus is 70°C!

**N** NOTE: Care should be taken when choosing a heat sink to ensure that there is good thermal flow, otherwise hot spots may occur in the IM481H Plus which will reduce the effectiveness of the thermal protection.

## Electrical Specifications

Test Parameters:  $T_A = 25^\circ\text{C}$ ,  $+V = 48\text{V}$

Specification	Test Condition / Notes	Min	Typ	Max	Units
Input Voltage		12	45	48*	V
Phase Output Current	RMS	0.14	–	1.5	A
	Peak	–	–	2.1	A
Quiescent Current (+5V, pin 12)	Inputs/Outputs Floating	–	1	–	mA
Quiescent Current (+5V, pin 14)	Inputs/Outputs Floating	–	140	225	mA
Active Power Dissipation	$I_{OUT} = 1\text{A RMS}$	–	–	2	W
Low Level Input Voltage	All Inputs	–	–	1.2	V
High Level Input Voltage	All Inputs Except RESET	2.0	–	–	V
	RESET	–	2.3	–	V
Input Pull-Up Resistance	RES SEL 0-3, ENABLE	–	20	–	k $\Omega$
	STEP CLOCK DIRECTION	–	2.0	–	k $\Omega$
	RESET	–	1.0	–	k $\Omega$
	FAULT IN	–	4.7	–	k $\Omega$
Low Level Output Current	FAULT, FULLSTEP, Inactive	2	–	–	mA
High Level Output Current	FAULT, FULLSTEP, Active	2	–	–	mA
Low Level Output Voltage, $V_{OL}$	$I_{OL} = 1.4\text{ mA}$	–	–	0.5	V
High Level Output Voltage, $V_{OH}$	$I_{OH} = -1.7\text{ mA}$	2.3	–	–	V
Step Clock	Rate	–	–	2.5	MHz
	Width	200	–	–	nS
	Response	–	650	–	nS
Direction Setup/Hold		–	50/100	–	nS
MSEL Setup		–	4	–	mS
Full Step (zero cross)	Response	–	650	–	nS
Reset Pulse Width		1	–	–	$\mu\text{S}$
Enable	Response	–	4	–	mS
Variable PWM Frequency (step rate dependent)	min: reset to low speed max: high speed	20		60	kHz

\* Includes Back EMF of Motor

Table 2.1: IM481H Plus DC Electrical Characteristics

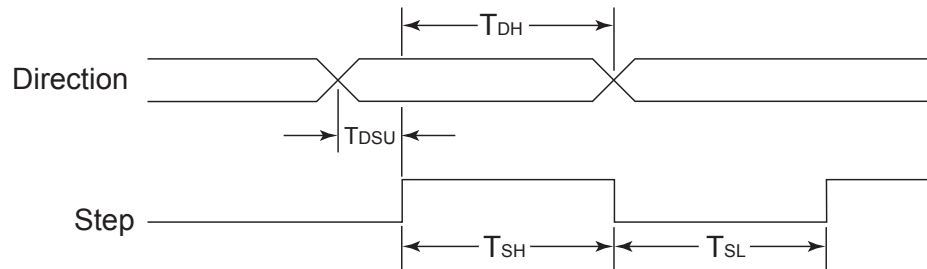

**Direction Timing**  
 $T_{DH} = 50\text{ nS Minimum}$   
 $T_{DSU} = 0\text{ nS Minimum}$

**Step Clock Timing**  
 $T_{SH} = 200\text{ nS Minimum}$   
 $T_{SL} = 200\text{ nS Minimum}$

Figure 2.2: Step and Direction Timing Diagram

## Pin Assignment and Description

PIN #	PIN NAME	FUNCTION
1	PHASE A	Phase A of the stepping motor is connected pin 1. See Section 6.
2	$\overline{\text{PHASE A}}$	$\overline{\text{Phase A}}$ of the stepping motor is connected to pin 2. See Section 6.
3	CURRENT REDUCTION ADJUSTMENT	Phase current reduction adjustment input. A resistor connected between this pin and pin 4 will proportionately reduce current in both windings 0.5 seconds after the last positive edge of the step clock input. See Figure 3.1
4	CURRENT REFERENCE	Phase current reference output. A resistor is connected between this 1 mA current source output and the Ground pin (pin 11) to generate the voltage used to set the peak phase current in the motor. See Figure 3.2
5	CURRENT ADJUSTMENT	Phase current adjustment input. A voltage applied to this input sets the peak phase current in the motor. Note: Pins 4 and 5 must be connected via a 1/8W 1% ohms resistor referenced to ground if using the internal current reference.
6	$\overline{\text{FAULT INPUT}}$	A low signal on this input will generate a latched fault condition. The fault condition can only be cleared by cycling power or resetting the driver by toggling the Reset Input.
7-10	RESOLUTION SELECT 0-3	Microstep resolution select inputs. Used to select the number of microsteps per full step of the motor. See Microstep Selection Table 3.3.
11	SUPPLY GROUND	Power Supply Return (Ground).
12	+V	Motor Power Supply Input. The power output of a +12 tp +48 VDC Unregulated Linear or Switch mode supply is connected here.
13	$\overline{\text{RESET INPUT}}$	When low, this input will reset the driver (phase outputs will disable). When released, the driver will be at its initial state (Phase A off, Phase B on).
14	+5V	+5VDC supply input. This supply is used to power the internal logic. The +5VDC supply should be referenced to pin 11 (supply ground). The 5 Volt supply must be a regulated DC Supply capable of supplying 150 mA minimum with no more than 5% ripple voltage.
15	STEP CLOCK INPUT	A positive going edge on this input advances the motor one increment. The size of the increment is dependent on the microstep select inputs.
16	DIRECTION INPUT	This input is used to change the direction of the motor. Physical direction also depends on the connection of the motor windings.
17	ENABLE INPUT	This input is used to enable/disable the output section of the driver. When high, the outputs are enabled. However, this input does not inhibit the step clock. Therefore when disabled the outputs will update by the number of clock pulses (if any) applied to the driver while it had been disabled.
18	ON FULL STEP OUTPUT	This totem-pole output indicates when the driver is positioned at a full step. This output can be used to count the number of full steps the motor has moved, regardless of the number of microsteps in between. This output is active high.
19	FAULT OUTPUT	This totem-pole output indicates a short circuit has occurred or a low signal was detected on the Fault input. This output is active high.
20	PHASE B	Phase B of the stepping motor is connected to pin 20. See Section 6.
21	$\overline{\text{PHASE B}}$	$\overline{\text{Phase B}}$ of the stepping motor is connected to pin 21. See Section 6.

Table 2.2: Pin Assignment and Description

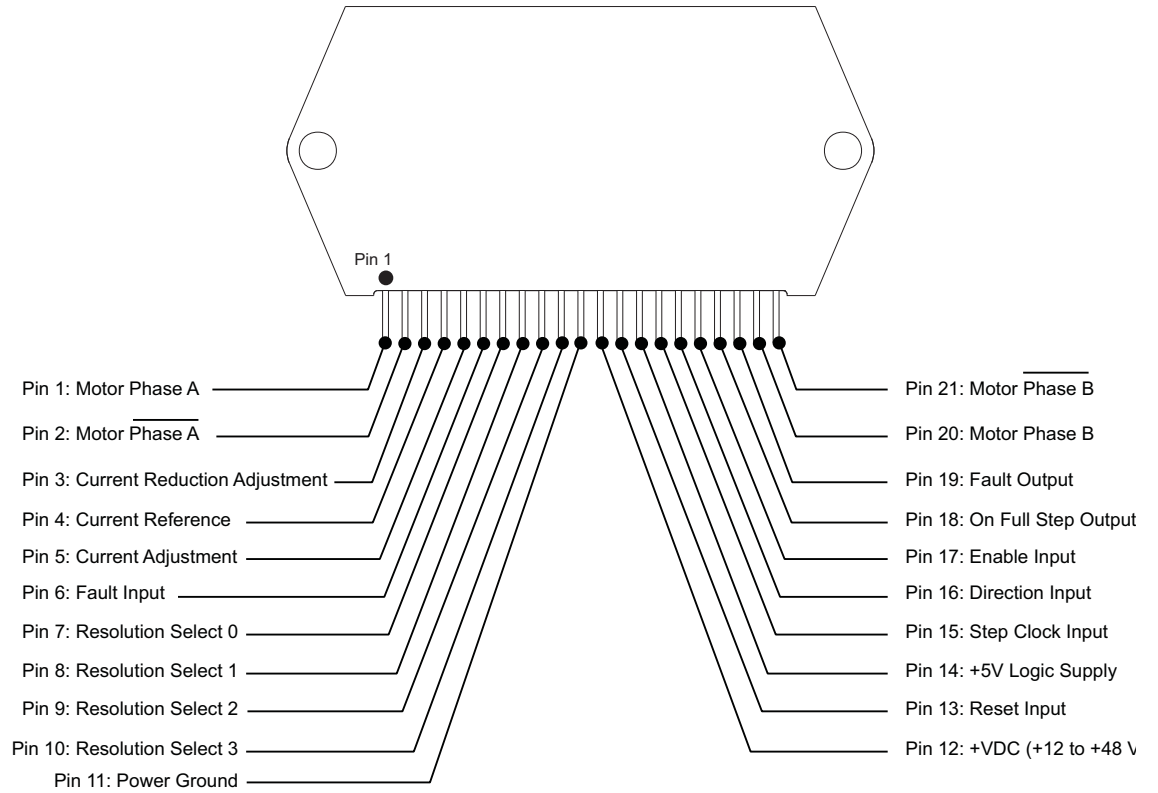

Figure 2.3: IM481H Plus Pinout

## Options/Accessories

DESCRIPTION	PART NUMBER
Thermal Pad .....	TI-481
Interface Board .....	INT-481
Heat Sink Kit (Includes mounting hardware and Thermal Pad) .....	H-481
21 Pin Right Angle Connector .....	HY481-CN021
Small End Screw Driver .....	SD1

# Section 3

## Mounting the IM481H Plus

### Section Overview

This section covers mounting the IM481H Plus in your system. The following mounting options are covered:

- Mounting the IM481H Plus to a PCB.
- Mounting the IM481H Plus.
- Recommended Mounting Hardware.

### Direct Mounting the IM481H Plus to a PC Board

The IM481H Plus hybrid is designed to be soldered directly into a PC board. The following diagram contains the hole pattern and recommended pad sizes for direct mounting of the IM481H Plus.

#### Recommended Soldering Practices

Max. Soldering Temp ..... 371°C (700°F)  
Max. Soldering Time ..... 10 sec.

#### Recommended Solder

Novanta IMS Recommends the use of a SAC305 (Sn96.5Ag3.0Cu0.5) lead free solder for RoHS compliant circuit board manufacture.

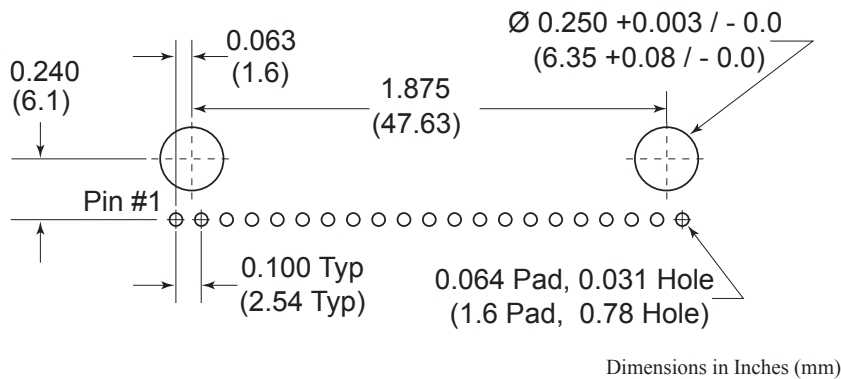

Figure 3.1: PCB Hole Pattern (Direct Mounting of the IM481H Plus to a PC Board)

**N** **NOTE:** The hardware items “A” through “H” are supplied with the H-481 Heat Sink Kit. If the H-481 is not used, the mounting hardware is not supplied.

**NOTE:** The torque specification for the #6-32 INT-481 and IM481H Plus mounting screw is 5.0 - 7.0 in-lbs. (See the hardware list on the following page.)

**WARNING!** The Heat Sink mounting surface must be a smooth, flat surface with no burrs, protrusions, cuttings or other foreign objects.

**WARNING!** If you are planning to wash your PCB it must be done prior to adding the IM481H Plus Driver or damage will occur.

## Mounting the IM481H Plus Using the Optional H-481 Heat Sink

Available as an option for the IM481H Plus is the H-481 Heat Sink kit. The kit contains all the mounting hardware required to mount the IM481H Plus Hybrid to the heat sink.

### Heat Sink Dimensions

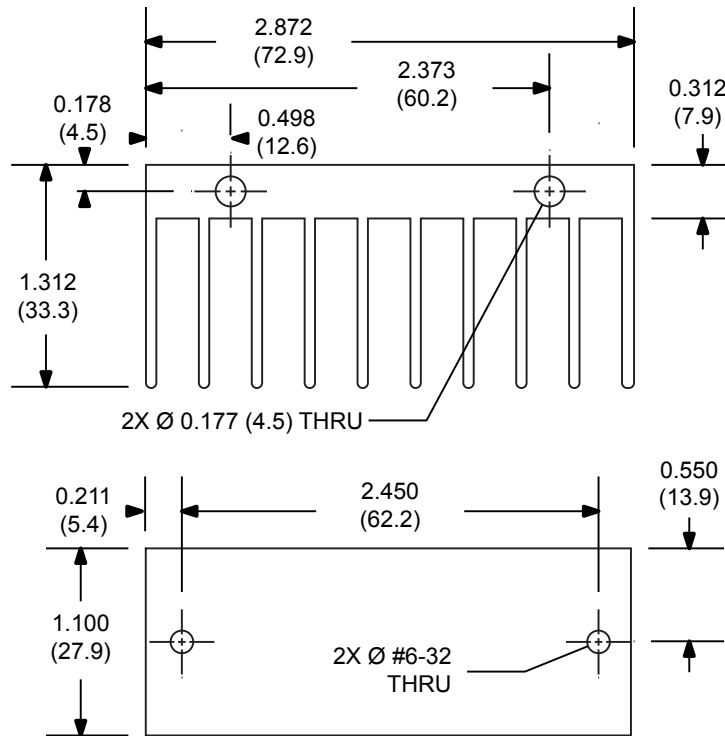

### Heat Sink Kit Contents

- ③ 1 - H-481 Heat Sink
- Ⓓ 2 - 8-32 x 1.375 ScREW
- Ⓐ 2 - 6-32 x 5/8 SCREW
- Ⓒ 2 - SPACERS
- Ⓕ 2 - #8 SPLIT WASHERS
- Ⓒ 2 - #6 FLAT WASHERS
- Ⓑ 2 - #6 SPLIT WASHERS

Figure 4.1: H-481 Heat Sink Kit

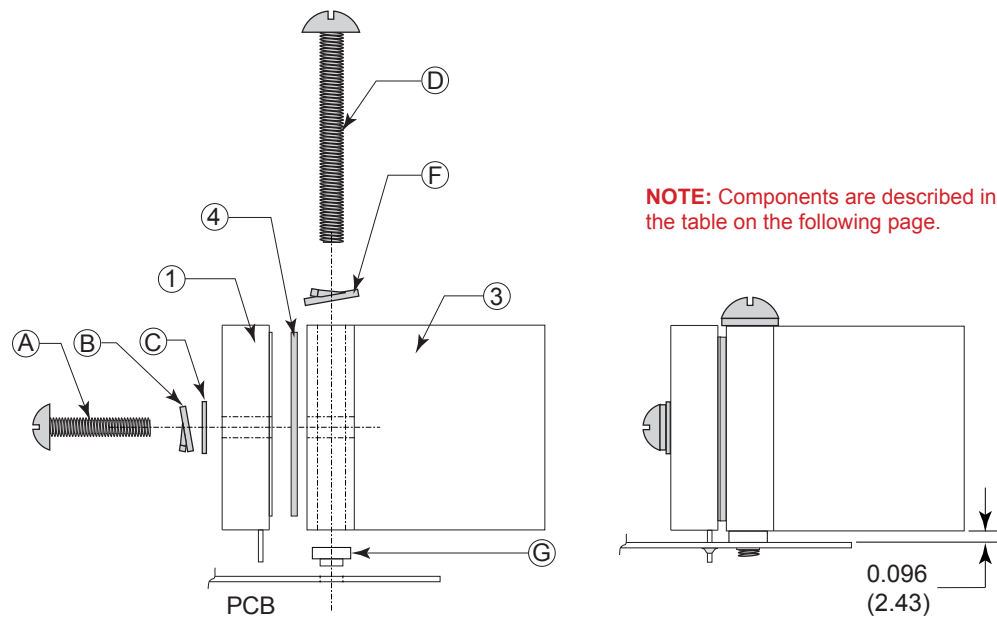

**NOTE:** Components are described in the table on the following page.

Figure 4.2: IM481H Plus Heat Sink Mounting

## Mounting the IM481H Plus Using the Optional INT-481 Interface Board

Available as an option for the IM481H Plus is the INT-483 Interface Board to ease prototyping and connection to the IM481H Plus. Full details for this interface board can be found in Appendix B of this document.

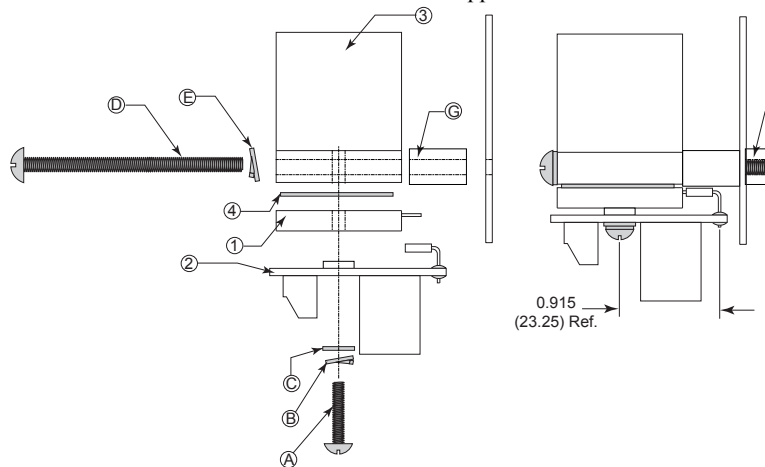

Figure 4.3: IM481H Plus Panel Mount with Heat Sink

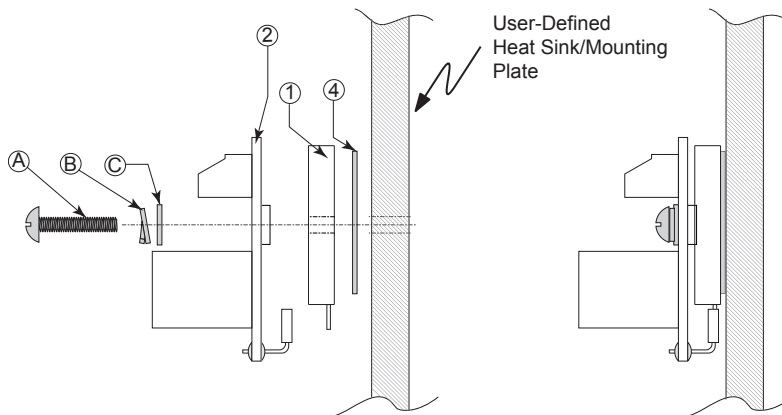

Figure 4.4: IM481H Plus Panel Mount without Heat Sink

Product/Item #	Description	Qty.
1	IM481H Plus Microstepping Driver	1
2	INT-481 Interface Board	1
3	H-481 Heat Sink	1
4	TI-481 Isolating Thermal Pad	1
A	#6-32x5/8" Pan Head Screw	2
B	#6 Split Lock Washer	2
C	#6 Flat Washer, 0.250" OD, 0.145" ID, 0.030" Thick	2
D	#8-32x13/8" Pan Head Screw	2
E	#8-32x2 Pan Head Screw	2
F	#8 Split Lock Washer	2
G	#8-32 Internally Threaded Broaching Nut	2
H	Spacer, 0.312" OD, 0.171" ID, 0.500" Long	2

Table 3.1: H-481 Heat Sink Mounting Hardware

# Section 4

## Power Supply Requirements

### Section Overview

This section covers the power supply requirements of the IM481H Plus. Precise wiring and connection details are to be found in Section 7: Interfacing to the IM481H Plus. The following is covered by this section:

- Selecting a Power Supply.
- Recommended Wiring.
- AC Line Filtering.

### Selecting a Power Supply

#### Selecting a Motor Supply (+V)

Proper selection of a power supply to be used in a motion system is as important as selecting the drive itself. When choosing a power supply for a stepping motor driver, there are several performance issues that must be addressed. An undersized power supply can lead to poor performance and possibly even damage to your drive.

#### The Power Supply - Motor Relationship

Motor windings can basically be viewed as inductors. Winding resistance and inductance result in an L/R time constant that resists the change in current. To effectively manipulate the rate of change, the voltage applied is increased. When traveling at high speeds, there is less time between steps to reach current. The point where the rate of commutation does not allow the driver to reach full current is referred to as voltage mode. Ideally you want to be in current mode, which is when the drive is achieving the desired current between steps. Simply stated, a higher voltage will decrease the time it takes to charge the coil and, therefore, will allow for higher torque at higher speeds.

Another characteristic of all motors is back EMF. Back EMF is a source of current that can push the output of a power supply beyond the maximum operating voltage of the driver. As a result, damage to the stepper driver could occur over a period of time.

#### The Power Supply - Driver Relationship

The IM481H Plus is very current efficient as far as the power supply is concerned. Once the motor has charged one or both windings of the motor, all the power supply has to do is replace losses in the system. The charged winding acts as an energy storage in that the current will recirculate within the bridge and in and out of each phase reservoir. This results in a less than expected current draw on the supply.

Stepping motor drivers are designed with the intent that a user's power supply output will ramp up to greater than or equal to the minimum operating voltage. The initial current surge is substantial and could damage the driver if the supply is undersized. The output of the power supply could fall below the operating range of the driver upon a current surge, if it is undersized. This could cause the power supply to start oscillating in and out of the voltage range of the driver and result in damage to either the supply, the driver, or both. There are two types of supplies commonly used, regulated and unregulated, both of which can be switching or linear. Each have advantages and disadvantages.

#### Regulated vs. Unregulated

An unregulated linear supply is less expensive and more resilient to current surges, however, the voltage decreases with increasing current draw. This can cause problems if the voltage drops below the working range of the drive. Also of concern are the fluctuations in line voltage. This can cause the unregulated linear supply to be above or below the anticipated or acceptable voltage.

A regulated supply maintains a stable output voltage, which is good for high speed performance. These supplies are also not effected by line fluctuations, however, they are more expensive. Depending on the current regulation, a regulated supply may crowbar or current clamp and lead to an oscillation that, as previously stated, can cause damage to the driver and/or supply. Back EMF can cause problems for regulated supplies as well. The current regeneration may be too large for the regulated supply to absorb. This could lead to an over voltage condition which could damage the output circuitry of the IM481H Plus.

Non Novanta IMS switching power supplies and regulated linear supplies with over-current protection are not recommended because of their inability to handle the surge currents inherent in stepping motor systems.

Motor Power Specification	
Recommended Supply Type	Unregulated DC
Ripple Voltage	± 10%
Output Voltage	+12 to +48 VDC
Output Current*	0.75 A Peak

\* The output current is dependant on the power supply voltage, the motor selection and the load.

Table 4.1: Motor Power Supply Specifications

### Recommended IMS Power Supplies

Novanta IMS has designed a series of low cost miniature unregulated Switching and Linear Supplies that can handle extreme varying load conditions. This makes them ideal for stepper motor drives and DC servo motors. Each of these is avail-able in either 120 or 240 VAC configuration. See the Novanta IMS Catalog or website (<https://novantaim.com>) for more information. Listed below are the power supplies recommended for use with the IM481H Plus.

#### IP402/ISP200-4

	Range
120 VAC Version .....	102-132 VAC
240 VAC Version .....	204-264 VAC
IP402 Unregulated Linear Supply	
No Load Output Voltage* .....	39 VDC @ 0 Amps
Continuous Output Rating* .....	30 VDC @ 1 Amps
Peak Output Rating* .....	25 VDC @ 2 Amps
ISP200-4 Unregulated Switching Supply	
No Load Output Voltage* .....	41 VDC @ 0 Amps
Continuous Output Rating* .....	38 VDC @ 1.5 Amps
Peak Output Rating* .....	35 VDC @ 3 Amps

\* All measurements were taken at 25°C, 120 VAC, 60 Hz.

### Selecting a +5VDC Supply

+5 VDC Power Specification	
Recommended Supply Type	Regulated DC
Ripple Voltage	± 5%
Output Voltage	+5 VDC
Output Current*	150mA

Table 4.2: +5VDC Power Supply Specifications

 **NOTE:** With the exception of Novanta IMS Power Supplies, Switching Power Supplies and regulated linears with over-current protection are not recommended because of their inability to handle surge currents. If multiple drivers are to be run off of one power supply each drive should have separate power and ground wires that connect directly to the output capacitor of the power supply.

 **WARNING!** The Fault Output will latch on power up when switching DC Power (Not Recommended). Slowing the DC rise time will allow the unit to power up without latching into fault.

 **WARNING!** When using an unregulated power supply, care should be taken that the output voltage does not exceed the maximum driver input voltage because of variations in line voltage. It is recommended that an input line filter be used on the power supply to limit voltage spikes to the driver!

Do not connect or disconnect motor leads with power applied! Do not connect or disconnect DC input to the IM481H Plus with power applied! Disconnect the AC power side to power down the DC Supply.

For battery operated systems, conditioning measures should be taken to prevent device damage caused by in-rush current draws, transient arcs and high voltage spikes.



**WARNING!** Verify that the power supply wiring is correct prior to power application.

If +V and GND are connected in reverse order, catastrophic damage to the IM481H Plus may occur! Ensure that the power supply output voltage does not exceed +48 VDC, the maximum input voltage of the IM481H Plus!



**WARNING!** Hazardous voltage levels may be present if using an

open frame power supply to power the IM481H Plus!

## Recommended Wiring

### Rules of Wiring and Shielding

Noise is always present in a system that involves both high power and small signal circuitry. Regardless of the power configuration used for your system, there are some wiring and shielding rules that should be followed to keep the noise to signal ratio as small as possible.

#### Rules of Wiring

- Power supply and motor wiring should be shielded twisted pairs run separately from signal carrying wires.
- A minimum of 1 twist per inch is recommended.
- Motor wiring should be shielded twisted pairs using 20 AWG wire or, for distance greater than 5 feet, 18 gauge or better.
- Power ground return should be as short as possible to established ground.
- Power supply wiring should be shielded twisted pairs. Use 18 gauge wire if load is less than 4 amps, or 16 gauge for more than 4 amps.
- Do not “Daisy-Chain” power wiring to system components.

#### Rules of Shielding

- The shield must be tied to zero-signal reference potential. In order for shielding to be effective, it is necessary for the signal to be earthed or grounded.
- Do not assume that earth ground is true earth ground. Depending on the distance to the main power cabinet, it may be necessary to sink a ground rod at a critical location.
- The shield must be connected so that shield currents drain to signal-earth connections.
- The number of separate shields required in a system is equal to the number of independent signals being processed plus one for each power entrance.
- The shield should be tied to a single point to prevent ground loops.
- A second shield can be used over the primary shield, however, the second shield is tied to ground at both ends.

#### Recommended Power Supply Cables

Power supply cables must not run parallel to logic level wiring as noise will be coupled onto the logic signals from the power supply cables. If more than one driver is to be connected to the same power supply, run separate power and ground leads to each driver from the power supply. The following Belden cables (or equivalent) are recommended for use with the IM481H Plus.

Twisted pair jacketed ..... Belden Part# 9740 or equivalent 18 Gauge

#### AC Line Filtering

Since the output voltage of an unregulated power supply will vary with the AC input applied, it is recommended that an AC line filter be used to prevent damage to the IM481H Plus due to a lightning strike or power surge.

# Section 5

## Motor Requirements

### Section Overview

This section covers the motor configurations for the IM481H Plus.

- Selecting a Motor.
- Motor Wiring.
- Connecting the Motor.

### Selecting a Motor

When selecting a stepper motor for your application, there are several factors that need to be taken into consideration.

- How will the motor be coupled to the load?
- How much torque is required to move the load?
- How fast does the load need to move or accelerate?
- What degree of accuracy is required when positioning the load?

While determining the answers to these and other questions is beyond the scope of this document, they are details that you must know in order to select a motor that is appropriate for your application. These details will effect everything from the power supply voltage to the type and wiring configuration of your stepper motor. The current and microstepping settings of your IM481H Plus drive will also be effected.

### Types and Construction of Stepping Motors

The stepping motor, while classed as a DC motor, is actually an AC motor that is operated by trains of pulses. Although it is called a “stepping motor”, it is in reality a polyphase synchronous motor. This means it has multiple phases wound in the stator and the rotor is dragged along in synchronism with the rotating magnetic field. The IM481H Plus is designed to work with the following types of stepping motors:

- 1) Permanent Magnet (PM)
- 2) Hybrid Stepping Motors

Hybrid stepping motors combine the features of the PM stepping motors with the features of another type of stepping motor called a variable reluctance motor (VR), which is a low torque and load capacity motor that is typically used in instrumentation. The IM481H Plus cannot be used with VR motors as they have no permanent magnet.

On hybrid motors, the phases are wound on toothed segments of the stator assembly. The rotor consists of a permanent magnet with a toothed outer surface which allows precision motion accurate to within  $\pm 3$  percent. Hybrid stepping motors are available with step angles varying from  $0.45^\circ$  to  $15^\circ$  with  $1.8^\circ$  being the most commonly used. Torque capacity in hybrid steppers ranges from 5 - 8000 ounce-inches. Because of their smaller step angles, hybrid motors have a higher degree of suitability in applications where precise load positioning and smooth motion is required.

### Sizing a Motor for Your System

The IM481H Plus is a bipolar driver which works equally well with both bipolar and unipolar motors (i.e. 8 and 4 lead motors, and 6 lead center tapped motors).

To maintain a given set motor current, the IM481H Plus chops the voltage using a variable 20 to 60 kHz chopping frequency, which is dependent on the step clock rate, and a varying duty cycle. Duty cycles that exceed 50% can cause unstable chopping. This characteristic is directly related to the motor's winding inductance. In order to avoid this situation, it is necessary to choose a motor with a low winding inductance. The lower the winding inductance, the higher the step rate possible.

### Winding Inductance

Since the IM481H Plus is a constant current source, it is not necessary to use a motor that is rated at the same voltage as the supply voltage. What is important is that the IM481H Plus is set to the motor's rated current. See Section 7: Interfacing to the IM481H Plus for more details.

As was discussed in the previous section, Power Supply Requirements, the higher the voltage used the faster the current can flow through the motor windings. This in turn means a higher step rate, or motor speed. Care should be taken not to exceed the maximum voltage of the driver. Therefore, in choosing a motor for a system design, the best performance for a specified torque is a motor with the lowest possible winding inductance used in conjunction with highest possible driver voltage.

The winding inductance will determine the motor type and wiring configuration best suited for your system. While the equation used to size a motor for your system is quite simple, several factors fall into play at this point.

The winding inductance of a motor is rated in milliHenrys (mH) per Phase. The amount of inductance will depend on the wiring configuration of the motor.

The per phase winding inductance specified may be different than the per phase inductance seen by your IM481H Plus driver depending on the wiring configuration used. Your calculations must allow for the actual inductance that the driver will see based upon the motor's wiring configuration used.

Figure 5.1A shows a stepper motor in a series configuration. In this configuration, the per phase inductance will be 4 times that specified. For example: a stepping motor has a specified per phase inductance of 1.47mH. In this configuration the driver will see 5.88 mH per phase.

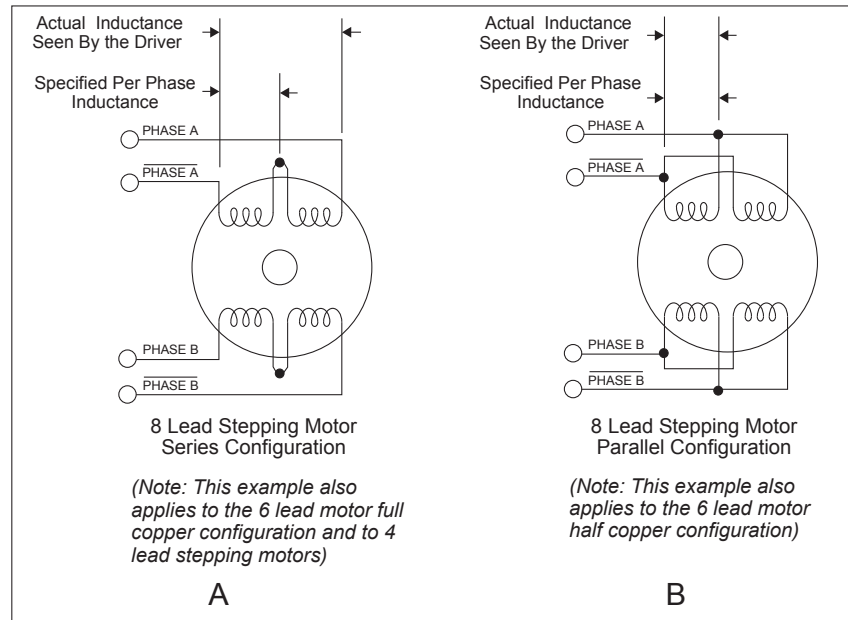

Figure 5.1 A & B: Per Phase Winding Inductance

Figure 5.1B shows an 8 lead motor wired in parallel. Using this configuration the per phase inductance seen by the driver will be as specified.

Using the following equation we will show an example of sizing a motor for a IM481H Plus used with an unregulated power supply with a minimum voltage (+V) of 18 VDC:

$$.2 \times 18 = 3.6 \text{ mH}$$

The maximum per phase winding inductance we can use is 3.6 mH.

**N** NOTE: In calculating the maximum phase inductance, the minimum supply output voltage should be used when using an unregulated supply.



Maximum Motor Inductance (mH per Phase) =  
 $.2 \times \text{Minimum Supply Voltage}$

### Recommended Novanta IMS Motors

Novanta IMS stocks the following 4 lead, 1.8° enhanced torque hybrid stepping motors that are recommended for the IM481H Plus.

These motors use a unique relationship between the rotor and stator to generate more torque per frame size while ensuring more precise positioning and increased accuracy.

The special design allows the motors to provide higher torque than standard stepping motors while maintaining a steadier torque and reducing torque drop-off.

Each frame size is available in 3 stack sizes, single or double shaft (with the exception of the size 23, 2.4A) and are available with or without encoders.

These CE rated motors are ideal for applications where higher torque is required. For more detailed information on these motors, please see the Novanta IMS Full Line catalog or the Novanta IMS website at <https://novantaim.com>.

## 17 Frame Enhanced (1.5A)

### Single Shaft

M-1713-1.5S .....	M-1713-1.5D
M-1715-1.5S .....	M-1715-1.5D
M-1719-1.5S .....	M-1719-1.5D

### Double Shaft

As with the power supply wiring, motor wiring should be run separately from logic wiring to minimize noise coupled onto the logic signals. Motor cabling exceeding 1' in length should be shielded twisted pairs to reduce the transmission of EMI (Electromagnetic Interference) which can lead to rough motor operation and poor system performance overall. For more information on wiring and shielding, please refer to Rules of Wiring and Shielding in Section 5 of this manual.

Below are listed the recommended motor cables:

### Dual Twisted Pair Shielded (Separate Shields)

< 5 feet .....	Belden Part# 9402 or equivalent 20 Gauge
>5 feet .....	Belden Part# 9368 or equivalent 18 Gauge

When using a bipolar motor, the motor must be within 100 feet of the drive.

## Connecting the Motor

The motor leads are connected to the following connector pins:

### Pins

Phase	Connector: Pin
Phase B .....	Pin 20
Phase B .....	Pin 21
Phase A .....	Pin 1
Phase A .....	Pin 2

## 8 Lead Motors

8 lead motors offer a high degree of flexibility to the system designer in that they may be connected in series or parallel, thus satisfying a wide range of applications.

### Series Connection

A series motor configuration would typically be used in applications where a higher torque at low speeds is needed. Because this configuration has the most inductance, the performance will start to degrade at higher speeds. Use the per phase (or unipolar) current rating as the peak output current, or multiply the bipolar current rating by 1.4 to determine the peak output current.

### Parallel Connection

An 8 lead motor in a parallel configuration offers a more stable, but lower torque at lower speeds. But because of the lower inductance, there will be higher torque at higher speeds. Multiply the per phase (or unipolar) current rating by 1.96, or the bipolar current rating by 1.4, to determine the peak output current.

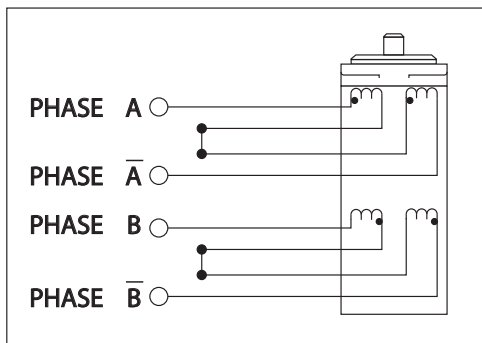

Figure 5.2: 8 Lead Series Motor Connections

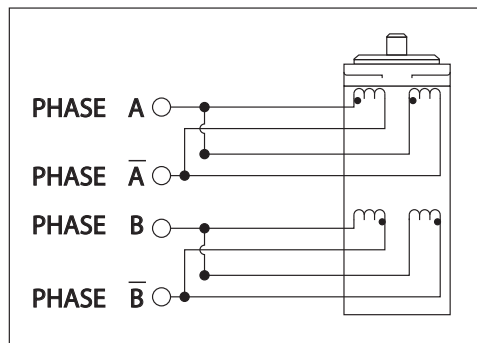

Figure 5.3: 8 Lead Parallel Motor Connections



**WARNING!** Do not connect or disconnect motor or power leads with power applied!



**NOTE:** The physical direction of the motor with respect to the direction input will depend upon the connection of the motor windings. To switch the direction of the motor with respect to the direction input, switch the wires on either Phase A or Phase B outputs.

## 6 Lead Motors

Like 8 lead stepping motors, 6 lead motors have two configurations available for high speed or high torque operation. The higher speed configuration, or half coil, is so described because it uses one half of the motor's inductor windings. The higher torque configuration, or full coil, uses the full windings of the phases.

### Half Coil Configuration

As previously stated, the half coil configuration uses 50% of the motor phase windings. This gives lower inductance, hence, lower torque output. Like the parallel connection of 8 lead motor, the torque output will be more stable at higher speeds. This configuration is also referred to as half copper. In setting the driver output current multiply the specified per phase (or unipolar) current rating by 1.4 to determine the peak output current.

### Full Coil Configuration

The full coil configuration on a six lead motor should be used in applications where higher torque at lower speeds is desired. This configuration is also referred to as full copper. Use the per phase (or unipolar) current rating as the peak output current.

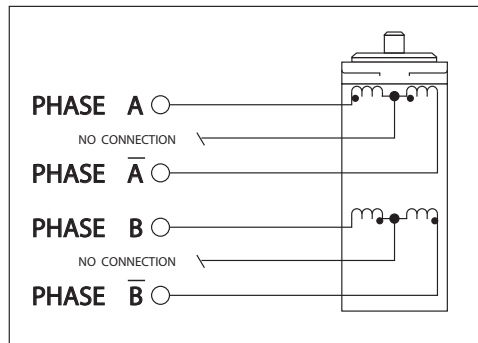

Figure 5.4: 6 Lead Full Coil (Higher Torque) Motor

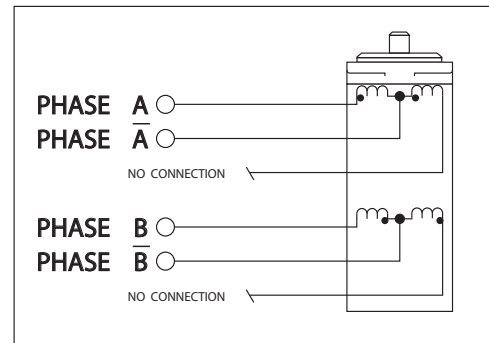

Figure 5.5: 6 Lead Half Coil (Higher Speed) Motor Connections

## 4 Lead Motors

4 lead motors are the least flexible but easiest to wire. Speed and torque will depend on winding inductance. In setting the driver output current, multiply the specified phase current by 1.4 to determine the peak output current.

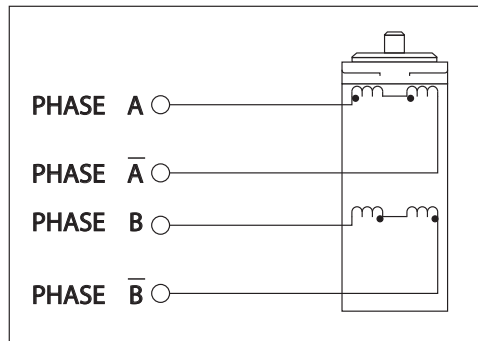

Figure 5.6: 4 Lead Motor Connections

# Section 6

## Interfacing to the IM481H Plus

### Section Overview

The IM481H Plus was designed to be incorporated directly in the user's printed circuit board. In order to operate, the IM481H Plus must have the following connections:

- Motor Power (+V).
- +5VDC Input.
- MSEL Inputs.
- Current Adjust (Reduction is optional).
- Logic Interface.
- Minimum Connections.

### Layout and Interface Guidelines

Logic level signals should not run parallel to motor phase signals. The motor phase signals will couple noise onto the logic level signals. This will cause rough motor motion and unreliable system operation. Motor phase signals should be run as pairs and should be separated from other signals by ground traces where possible.

When leaving the board, motor cables should not run parallel with other wires. Phases should be wired using twisted pairs. If motor cabling in excess of one foot is required, motor cabling should be shielded twisted pairs to reduce the transmission of EMI. The shield must be tied to AC ground at driver end only (or the supply ground if AC ground is not available). The motor end must be left floating.

If more than one driver is connected to the power supply, separate power and ground connections from each driver to the power supply should be used.

The power supply cables need to be a twisted pair if power is connected from a source external to the board. If multiple drivers are used with an external power source, and it is not possible to run separate power and ground connections to each driver, a low impedance electrolytic capacitor equivalent to two times the total capacitance of all driver capacitors and of equal voltage must be placed at the power input of the board.

### Motor Power

Pins 11 (ground) and 12 (+V) are used to connect the motor DC power to the IM481H Plus. Two local capacitors are needed, connected between pins 11 and 12 and located as close to the pins as possible, to ensure stable operation. See Figure 6.1.

The first capacitor is a low impedance, aluminum electrolytic. The continuous operating voltage of the capacitor should exceed the maximum supply voltage as well as any additional voltage caused by the motor's back EMF. The value of the capacitor should be approximately 150 microfarads for every 1 amp of peak per phase output current.

Along with the aluminum electrolytic, a 0.1 microfarad ceramic capacitor must be used to filter out high frequency noise. It should be located between the IM481H Plus power input pins and the aluminum electrolytic capacitor. The continuous operating voltage of the capacitor should exceed the maximum supply voltage as well as any additional voltage caused by the motor's back EMF.

For power supply specifications and recommendations, see Section 5: Power Supply Requirements.

### +5 VDC Input

The IM481H Plus requires an external regulated +5VDC power supply. The supply is connected between pins 11 (ground) and 14 (+5VDC). A 22 microfarad 10v tantalum capacitor must be placed as close to the IM481H Plus as possible between the +5VDC input pin (14) and ground.

The +5VDC supply ground and the motor supply ground should not be connected together at the power supplies. The common ground connection between the motor power supply and the +5VDC supply should be made at the ground pin of the additional electrolytic capacitor used for the motor supply.

The Figure 6.1 shows the proper connection of the external +5VDC supply to the IM481H Plus.



CALCULATING THE VALUE OF THE INPUT CAPACITORS

EXAMPLE: 1.4A (Peak Output Current @ 45VDC) X 150 $\mu$ F = 210 $\mu$ F 63V

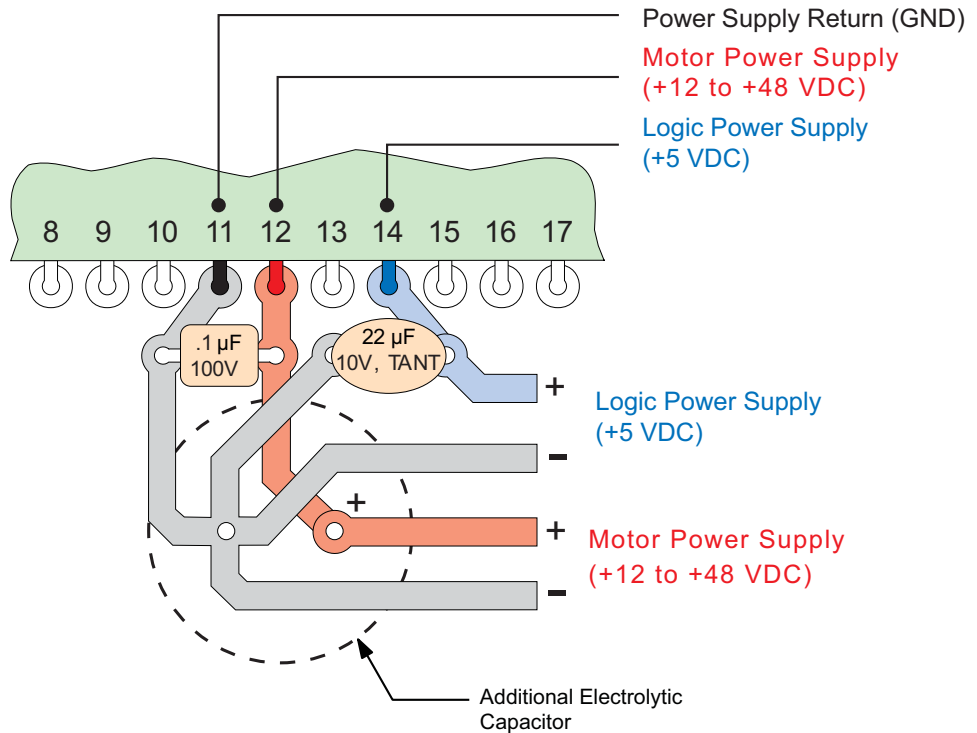

Figure 6.1: +5 VDC Power Supply XZConnection

## Controlling The Output Current Using the Current Adjustment Input

For any given motor, the output current used for microstepping is determined differently from that of a half/full step driver.

In the IM481H Plus, a sine/cosine output function is used in rotating the motor. Therefore, when microstepping, the specified phase current of the motor is considered an RMS value.

### Determining the Output Current

Stepper motors can be configured as 4, 6 or 8 leads. Each configuration requires different currents. Shown below are the different lead configurations and the procedures to determine the peak per phase output current setting that would be used with different motor/lead configurations.

#### 4 Lead Motors

Multiply the specified phase current by 1.4 to determine the peak output current.



EXAMPLE: A 4 lead motor has a specified phase current of 2.0A

$2.0A \times 1.4 = 2.8 \text{ Amps Peak}$

#### 6 Lead Motors

- 1) When configuring a 6 lead motor in a half coil configuration (i.e. connected from one end of the coil to the center tap (high speed configuration)) multiply the specified per phase (or unipolar) current rating by 1.4 to determine the peak output current.



EXAMPLE: A 6 lead motor in half coil configuration has a specified phase current of 3.0A

$3.0A \times 1.4 = 4.2 \text{ Amps Peak}$

- When configuring the motor so the full coil is used (i.e. connected from end-to-end with the center tap floating (higher torque configuration)) use the per phase (or unipolar) current rating as the peak output current.



**WARNING!**  
A current adjustment resistor or reference voltage

is always necessary to keep the Driver and/or Motor in a safe operating range.

DO NOT operate the IM481H Plus Drivers without a current control in place.



EXAMPLE: A 6 lead motor in full coil configuration with a specified phase current of 3.0A

3.0A per phase = 3.0 Amps Peak

## 8 Lead Motors

### SERIES CONNECTION:

- When configuring the motor windings in series, use the per phase (or unipolar) current rating as the peak output current, or multiply the bipolar current rating by 1.4 to determine the peak output current.



EXAMPLE: An 8 lead motor in series configuration with a specified unipolar current of 3.0A

3.0A per phase = 3.0 Amps Peak

An 8 lead motor in series configuration with a specified bipolar current of 2.8A

$2.8 \times 1.4 = 3.92$  Amps Peak

### PARALLEL CONNECTION:

- When configuring the motor windings in parallel, multiply the per phase (or unipolar) current rating by 2.0 or the bipolar current rating by 1.4 to determine the peak output current.



EXAMPLE: An 8 lead motor in parallel configuration with a specified unipolar current of 2.0A.

2.0A per phase X 2.0 = 4.0 Amps Peak

An 8 lead motor in parallel configuration with a specified bipolar current of 2.8A.

$2.8 \times 1.4 = 3.92$  Amps Peak

## Setting the Output Current

The output current can be set on the IM481H Plus one of two ways:

- By connecting the current reference output (Pin 4) to the current adjust input (Pin 5) and placing a resistor between this connection and ground (Pin 11). This uses the internal 1mA current source provided at the current reference Pin 4 (Figure 6.2).
- By applying an external reference voltage to Pin 4 (Figure 6.3).

Table 6.1 defines the current adjust resistor values and the reference voltage required for peak per phase output current setting.

The current adjustment resistor external reference voltage used to set the per phase output current of the IM481H Plus sets the peak per phase output of the sine/cosine waves not the RMS value. Therefore, the peak per phase output current must be used to determine the value to which the IM481H Plus will be set.

The relationship between the output current and the resistor value is as follows:



Peak Output Current (Amps) x 1000 = Resistor Value (Ohms) EXAMPLE:

To set the peak output current of the IM481H Plus to 1.4 Amps:  $1.4 \div .001$

= Resistor Value = 1400

**N** **NOTE:** When connecting the current reduction resistor between pins 3 and 4, the connections should be made as short as possible to help minimize noise coupled into the driver.

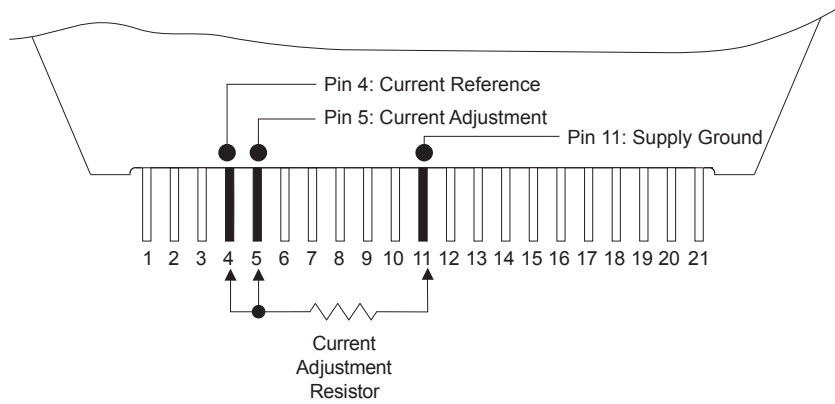

Figure 6.2: Current Adjust Resistor

**!** **WARNING!** Although stepping motors will run hot when configured correctly, damage may occur to a motor if a higher than specified current is used. Most specified motor currents are maximum values. Care should be taken when exceeding these values.

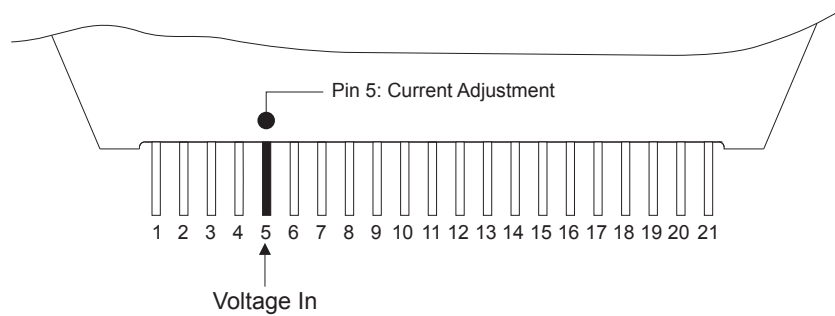

Figure 6.3: Current Adjust Voltage

Peak Output Current (Amps)	Reference (Volts)	Resistor Value (1% (Ohms)
0.20	0.20	200
0.25	0.25	249
0.30	0.30	301
0.35	0.35	348
0.40	0.40	402
0.45	0.45	453
0.50	0.50	499
0.55	0.55	549
0.60	0.60	604
0.65	0.65	649
0.70	0.70	698
0.75	0.75	750
0.80	0.80	806
0.85	0.85	845
0.90	0.90	909
0.95	0.95	953
1.00	1.00	1000
1.05	1.05	1050
1.10	1.10	1100
1.15	1.15	1150

Peak Output Current (Amps)	Reference (Volts)	Resistor Value (1% (Ohms)
1.20	1.20	1210
1.25	1.25	1240
1.30	1.30	1300
1.35	1.35	1330
1.40	1.40	1400
1.45	1.45	1430
1.50	1.50	1500
1.55	1.55	1540
1.60	1.60	1580
1.65	1.65	1650
1.70	1.70	1690
1.75	1.75	1740
1.80	1.80	1780
1.85	1.85	1820
1.90	1.90	1870
1.95	1.95	1960
2.00	2.00	2000
2.05	2.05	2050
2.10	2.10	2100

Table 6.1: Current Adjust Reference/Output Current

## Reducing/Disabling the Output Current

Built into the IM481H Plus is the ability to automatically reduce the current in the motor windings after the completion of a move. The reduction occurs 0.5 seconds after the last positive going edge of the Step Clock input. The IM481H Plus will then revert back to the Current Adjustment setting at the next positive going edge of the Step Clock input.

To utilize this feature, the current reference output must be used to adjust the output current of the IM481H Plus and a resistor must be connected between pins 3 & 4 (See Figure 6.2). The value of the resistor will determine the amount of current reduction.

The amount of current per phase in the current reduction mode is related to the value of the current reference resistor and the current reduction resistor. When the current reduction circuit is activated, the current reduction resistor is paralleled with the current adjustment resistor. The parallel combination of the current reference and current reduction resistors determine the reduced current level. The relationship between the output current and the resistor's values is as follows:



$I_{Run}$  is the desired peak running current.  
Range 0.4A to 4A Peak

$I_{Hold}$  is the desired peak holding current.  
Range 0.2A to 4A Peak

$$R_{Red} = 1000 \times \frac{I_{Run} \times I_{Hold}}{(I_{Run} - I_{Hold})}$$

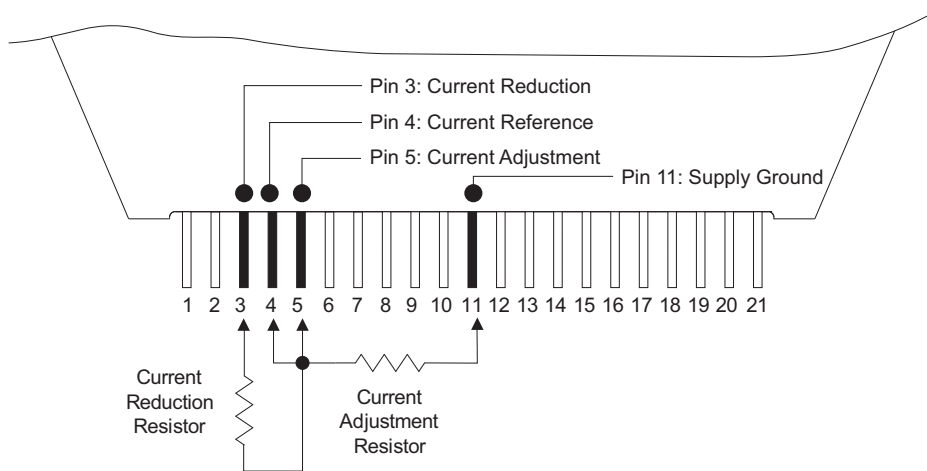

Figure 6.4: Current Reduction Adjustment Resistor Connection

If zero current is required at stand still then the Current Reduction Output (Pin 3) may be tied directly to the Enable Input (Pin 17). This will disable the outputs 0.5 seconds after the last step clock input.

When the Current Reduction Output is used in this manner an open collector output or blocking diode is **REQUIRED** or damage may occur to the internal circuitry. The diode or open collector transistor should be placed after the enable/reduction connection as shown in Figure 6.5.

If a voltage is used to set the output current the Current Reduction Output (Pin 3) will provide an open drain, active low output that occurs 0.5 seconds after the last step clock input and is referenced to Ground (Pin 11) the  $RDS_{ON}$  of the internal MOSFET is approximately  $6.5\Omega$ .

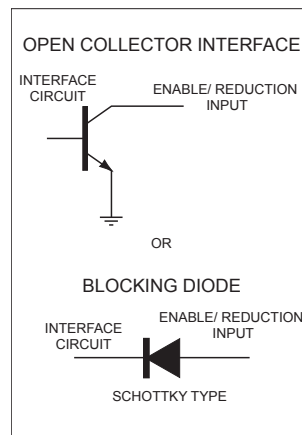

Figure 6.5: Interfacing the Current Reduction Input

**N**OTE: When connecting the current reduction resistor between pins 3 and 4, the connections should be made as short as possible to help minimize noise coupled into the driver.

## Interfacing the IM481H Plus Inputs

The inputs to the IM481H Plus are internally pulled up to the +5VDC supply. Figure 6.6 shows the inputs and their associated pull-up resistor values.

When interfacing to the IM481H Plus logic inputs an open collector output is recommended.

### Input Timing

A positive going edge at the Step Clock Input will advance the motor one step. The pulse must be a minimum 50nS wide. The IM481H Plus will present new phase data to the internal D/A converters 650nS after the Step Clock edge.

The Direction input must be stable on the positive going edge of Step Clock, and must be held for a minimum of 50nS after the step clock that advances a phase to zero cross.

The On Full Step output will assert 650nS after the Step Clock that advances a phase to zero cross.

The Reset and Enable inputs are asynchronous and may be asserted at any time.

The Reset requires a minimum pulse width of 1μS.

### The Microstep Resolution Select Inputs (MSEL)

Microsteps per step are selected via Pins 7 - 10. The table below shows the standard resolution values and the associated input settings.

The microstep resolution can be changed at any time. There is no need to reset the drive or cycle the power. On-the-fly "gear shifting" facilitates high speed slewing combined with high resolution positioning at either end of the move.

When the microsteps are changed so that the IM481H Plus does not fall on a full step (i.e. zero crossing of the sine/cosine) the IM481H Plus will readjust itself at the next pulse that would overshoot the fullstep position. This feature allows the IM481H Plus to readjust the motor position no matter what resolution is chosen when it is changed.

See Appendix D of this document for an "Electronic Gear Shifting" Application example showing a circuit to change the MSEL setting "on-the-fly".

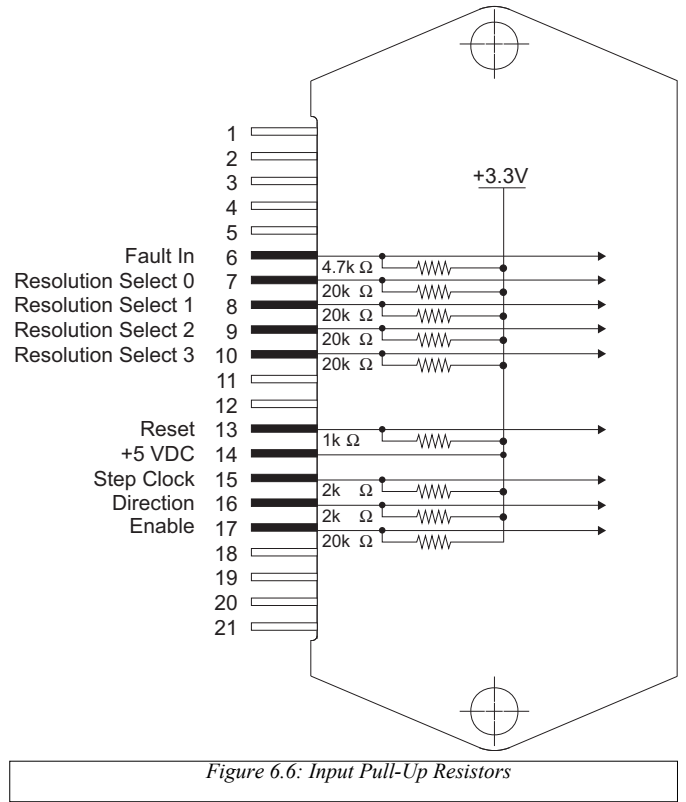

Figure 6.6: Input Pull-Up Resistors

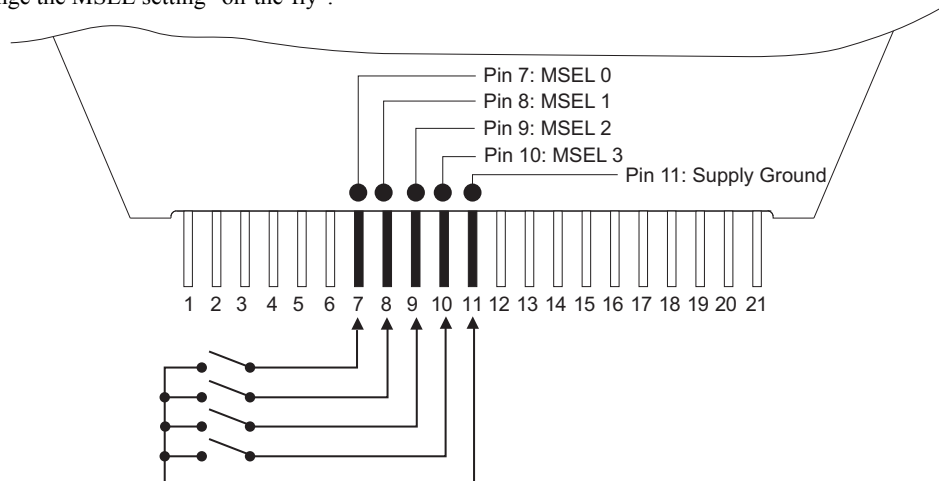

Figure 6.7: MSEL Inputs, Interface Example

Microstep Resolution (MSEL) Settings					
RESOLUTION (Microsteps/Step)	STEPS/REV (1.8° Step Motors)	MSEL 0 (P1:5)	MSEL 1 (P1:6)	MSEL 2 (P1:7)	MSEL 3 (P1:8)
BINARY					
2	400	LOW	LOW	LOW	LOW
4	800	HIGH	LOW	LOW	LOW
8	1,600	LOW	HIGH	LOW	LOW
16	3,200	HIGH	HIGH	LOW	LOW
32	6,400	LOW	LOW	HIGH	LOW
64	12,800	HIGH	LOW	HIGH	LOW
128	25,600	LOW	HIGH	HIGH	LOW
256	51,200	HIGH	HIGH	HIGH	LOW
DECIMAL					
5	1,000	LOW	LOW	LOW	HIGH
10	2,000	HIGH	LOW	LOW	HIGH
25	5,000	LOW	HIGH	LOW	HIGH
50	10,000	HIGH	HIGH	LOW	HIGH
125	25,000	LOW	LOW	HIGH	HIGH
250	50,000	HIGH	LOW	HIGH	HIGH
FULL STEP					
1	200	LOW	HIGH	HIGH	HIGH
DEGREES					
180	36,000	HIGH	HIGH	HIGH	HIGH

Table 6.2: Microstep Resolution Select Settings

### Interfacing the Fault and Reset Inputs

The IM481H Plus has a Fault input located at P1:4. This can be used to force a fault condition. When pulled low the signal is latched and the outputs will be disabled. The fault condition can only be cleared by resetting the drive or cycling the power.

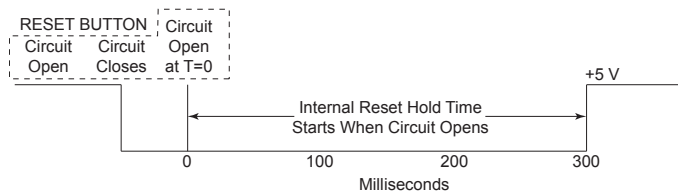

Figure 6.8: Reset Timing

When interfacing this input, an open collector output or blocking diode is REQUIRED or damage may occur to the internal fault detection circuitry.

The IM481H Plus also has a Reset Input. On power up, or if the Reset Input is Closed, the internal reset circuit will hold the input low for 100 to 300 milliseconds. The “holding” time does not begin until the Reset Input is Opened. (See Figure 6.9.)

When controlling multiple drives with a single Reset you must install blocking diodes at the input (Pin 14) of each drive. Because of the slight differences in Reset timing, this will prevent the drives from latching the Reset Input in the LOW state. (See Figure 6.10.)



**WARNING!** When interfacing the FAULT IN/RESET input, an open collector, tri-state output or blocking diode is REQUIRED or damage may occur. (See Figure 6.10.)



**NOTE:** When Powering or Resetting the IM481H Plus, the drive holds a FAULT Condition for 300 mS. Do not check for fault condition for the first 500 mS after power on or a reset.

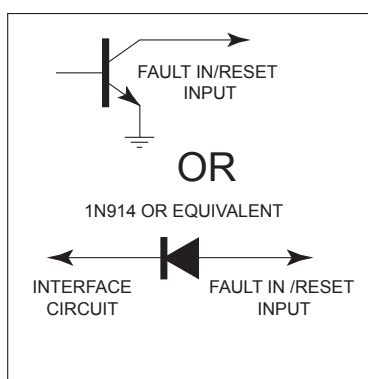

Figure 6.9: Interfacing the Fault In/Reset Inputs

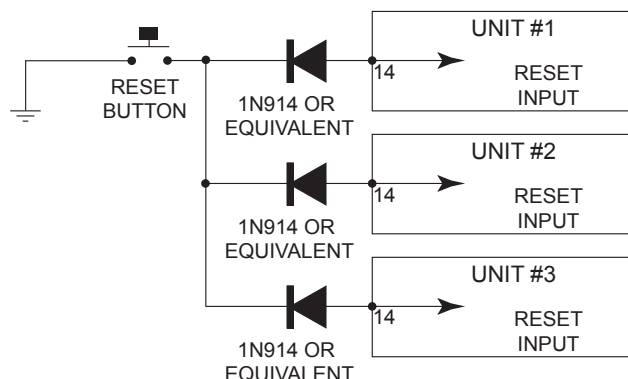
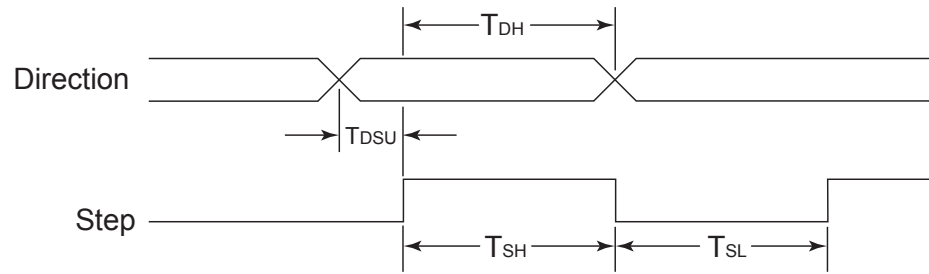

Figure 6.10: Multiple Drives - One Reset

### Step Clock and Direction

A positive going edge at the Step Clock Input will advance the motor one step. The pulse must be a minimum 200nS wide. The IM481H Plus will present new phase data to the internal D/A converters 650nS after the Step Clock edge.

The Direction input must be stable on the positive going edge of Step Clock, and must be held for a minimum of 50nS after the step clock that advances a phase to zero cross.



Direction Timing	Step Clock Timing
$T_{DH} = 50 \text{ nS Minimum}$	$T_{SH} = 200 \text{ nS Minimum}$
$T_{DSU} = 0 \text{ nS Minimum}$	$T_{SL} = 200 \text{ nS Minimum}$

Figure 6.11: Step and Direction Timing Diagram

## Interfacing the IM481H Plus Outputs

### Fullstep Output Signal

The Fullstep output signal from the IM481H Plus is an active high output at pin 18. This output is TRUE for the duration of the full step. A full step occurs when either Phase A or Phase B cross through zero (i.e. full current in one winding and zero current in the other winding). This full step position is a common position no matter what resolution is selected.

The full step output can be used to count the number of mechanical full steps the motor has traveled without having to count the number of microsteps in between. A controller that utilizes this output can greatly reduce system tracking overhead.

For an Example Application using the Fullstep Output please refer to Appendix D of this document.

### Fault Output

The IM481H Plus is internally protected against over temperature and over current.

If the IM481H Plus detects an over temperature condition it will shut down and will activate the fault output. Once the temperature drops to a safe operating temperature, the IM481H Plus must be power recycled (reboot) or toggle Reset Input to reset fault protection and resume operation.

The over temperature fault protection will activate when an operating temperature of 70°C is exceeded. Care should be taken when choosing and installing a heat sink so that there is a good thermal conduction, otherwise hot spots may occur in the IM481H Plus which will reduce the operating thermal range.

If an over current fault is detected by the IM481H Plus, the outputs will be disabled and at the same time the active high Fault Output (Pin 19) is enabled. The IM481H Plus cannot be re-enabled without resetting the driver or by cycling power (reboot).

The over current protection consists of Phase to Phase and +V to Phase.

The Fault Input (Pin 6) can be used to force a fault condition. When pulled low the signal is latched and the outputs will be disabled. The fault condition can only be cleared by cycling power (reboot) or resetting the driver by toggling the Reset Input.

## Minimum Connections

Figure 6:12 illustrates the minimum connections required to operate the IM481H Plus.

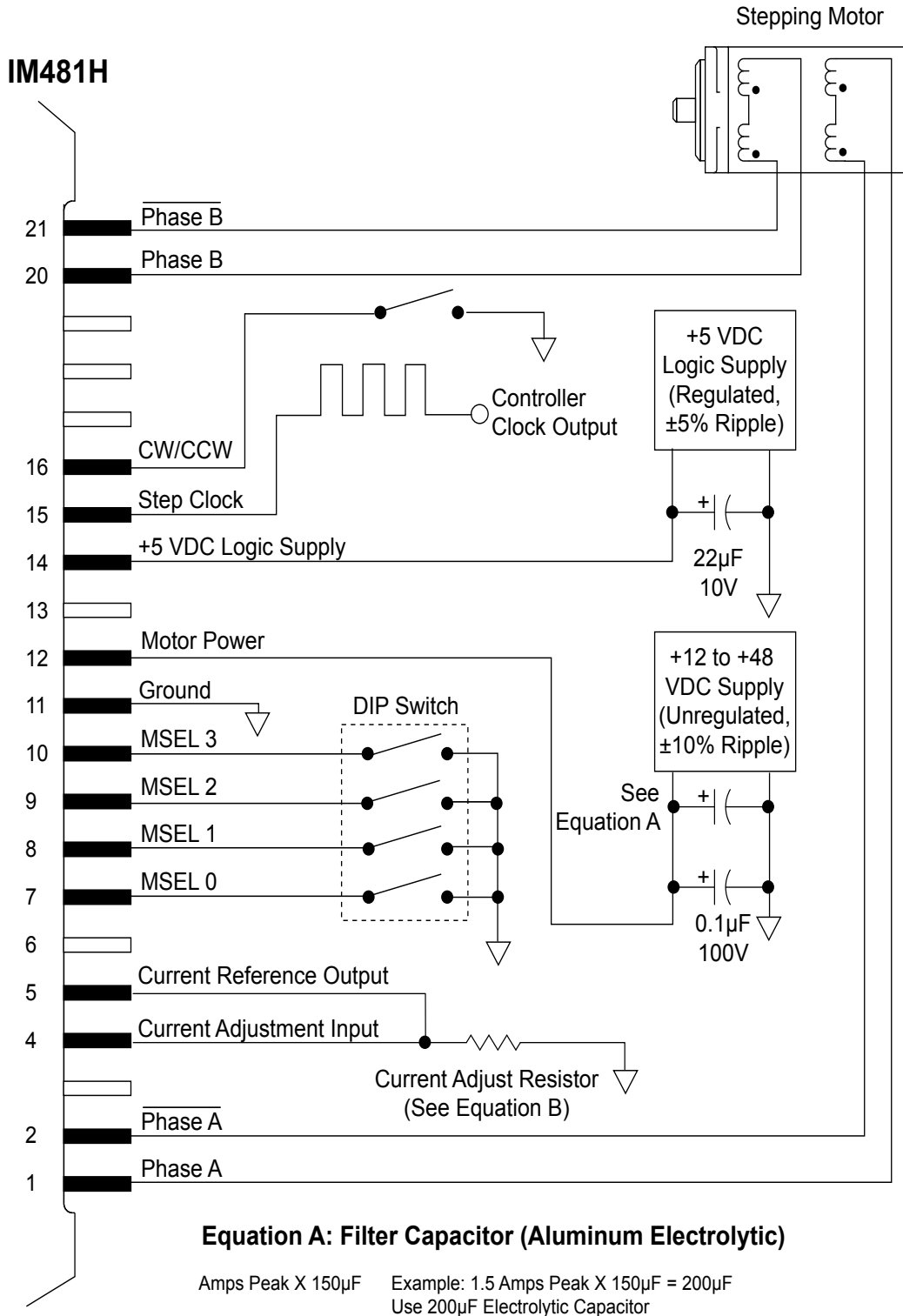

Figure 6.12: Minimum Connections

*Page Intentionally Left Blank*

### Section Overview

This section will cover the following:

- Basic Troubleshooting.
- Common Problems/Solutions.
- Contacting Application Support.
- Product Return Procedure.

### Basic Troubleshooting

In the event that your IM481H Plus doesn't operate properly, the first step is to identify whether the problem is electrical or mechanical in nature. The next step is to isolate the system component that is causing the problem. As part of this process you may have to disconnect the individual components that make up your system and verify that they operate independently. It is important to document each step in the troubleshooting process. You may need this documentation to refer back to at a later date, and, these details will greatly assist one of our application engineers in determining the problem should you need assistance.

Many of the problems that effect motion control systems can be traced to electrical noise, software errors, or mistakes in wiring.

### Common Problems and Solutions

#### *Symptom: Motor does not move.*

##### **Possible Problem**

- No power.
- Unit is in a reset condition.
- Invalid microstep resolution select setting.
- Current adjust resistor is wrong value or not in place.
- Fault condition exists.
- Unit is disabled.

#### *Symptom: Motor moves in the wrong direction.*

##### **Possible Problem**

- Motor phases may be connected in reverse.

#### *Symptom: Unit in fault.*

##### **Possible Problem**

- Current adjust resistor is incorrect value or not in place.
- Motor phase winding shorted.
- Power input or output driver electrically overstressed.
- Unit overheating.

**Symptom: Erratic motor motion.**

**Possible Problem**

- Motor or power wiring unshielded or not twisted pair.
- Logic wiring next to motor/power wiring.
- Ground loop in system.
- Open winding of motor.
- Phase bad on drive.

**Symptom: Motor stalls during acceleration.**

**Possible Problem**

- Incorrect current adjust setting or resistor value.
- Motor is undersized for application.
- Acceleration on controller is set to high.
- Power supply voltage too low.

**Symptom: Excessive motor and driver heating.**

**Possible Problem**

- Inadequate heat sinking / cooling.
- Current reduction not being utilized.
- Current set too high.

**Symptom: Inadequate holding torque.**

**Possible Problem**

- Incorrect current adjust setting or resistor value.
- Increase holding current with the current reduction adjust resistor.

**Contacting Application Support**

In the event that you are unable to isolate the problem with your IM481H Plus, the first action you should take is to contact the distributor from whom you originally purchased your product or Novanta IMS Application Support at 860-295-6102. Be prepared to answer the following questions:

- What is the application?
- In detail, how is the system configured?
- What is the system environment? (Temperature, Humidity, Exposure to chemical vapors, etc.)
- What external equipment is the system interfaced to?

Another product support resource is the Novanta IMS web site located at <https://novantaims.com/> for tech tips, applications and new product updates.

**Returning Your Product to Novanta IMS**

If Application Support determines that your IM481H Plus needs to be returned the factory for repair or replacement you will need to take the following steps:

- Obtain an RMA (Returned Material Authorization) number and shipping instructions at <https://novantaims.com/contacts/request-rma/>
- Enclose the product being returned in its original container if possible. If original packaging is unavailable ensure that the product is enclosed in approved antistatic packing material. Write the RMA number on the box.

The normal repair lead time is 10 business days, should you need your product returned in a shorter time period you may request that a “HOT” status be placed upon it while obtaining an RMA number. Should the factory determine that the product repair is not covered under warranty, you will be notified of any charges.

# Appendix B

## The INT481H Interface Board

### Section Overview

The purpose of this appendix is to acquaint the user with the specifications, basic wiring and configuration of the INT-481 Interface Board for the IM481H Plus Driver.

The INT-481 is an optional plug-on interface board which can be used with the IM481H PLUS to facilitate testing, or in situations where panel mounting the IM481H PLUS is preferred. The INT-481 contains extra circuitry which includes +5 VDC supply, optical isolation for step clock, direction, enable and reset, along with extra fault detection circuits, input capacitor, and fault and power LEDs. Wiring is done through a 15 pin screw terminal. A four position dip switch is supplied for microstep resolution selection.

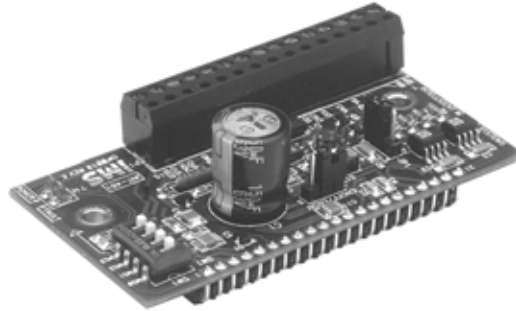

Figure B.1: INT481H

### Electrical Specifications

Test Parameters:  $T_A = 25^\circ\text{C}$ ,  $+V = 45\text{ VDC}$

Specification	Test Condition / Notes	Min	Typ	Max	Units
Opto Supply	Isolated Inputs	+5	–	+40	V
Input Forward Current	Isolated Inputs	5	–	15	mA
Input Forward Voltage	Isolated Inputs	–	1.5	1.7	V
Reverse Breakdown Voltage	Isolated Inputs	5	–	–	V
Signal Output Current	Full Step, Fault	–	–	20	mA
Drain-Source Voltage	Full Step, Fault	–	–	100	V
Drain-Source Resistance	Full Step, Fault	–	6.5	–	$\Omega$

Table B.1: INT-481H Electrical Specifications

### Mechanical Specifications

Dimensions in Inches (mm)

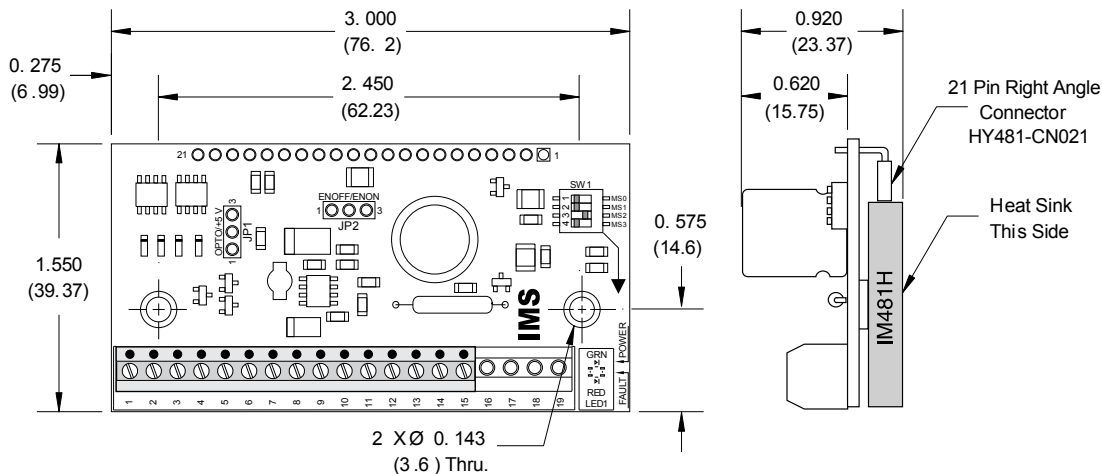

Figure B.2: INT-481H Mechanical Specifications

## Pin Assignment and Description

PIN #	PIN NAME	FUNCTION
1	$\overline{\text{PHASE B}}$	$\overline{\text{Phase B}}$ of the stepping motor.
2	PHASE B	Phase B of the stepping motor.
3	$\overline{\text{PHASE A}}$	$\overline{\text{Phase A}}$ of the stepping motor.
4	PHASE A	Phase A of the stepping motor.
5	ENABLE INPUT	This input is used to enable/disable the output section of the driver. When high, the outputs are enabled. However, this input does not inhibit the step clock. Therefore when disabled the outputs will update by the number of clock pulses (if any) applied to the driver while it had been disabled.
6	$\overline{\text{RESET INPUT}}$	When low, this input will reset the driver (phase outputs will disable). When released, the driver will be at its initial state (phase A off, phase B on).
7	OPTO SUPPLY	+5 to +24 VDC Optocoupler supply voltage.
8	DIRECTION INPUT	This input is used to change the direction of the motor. Physical direction also depends on the connection of the motor windings.
9	STEP CLOCK INPUT	A positive going edge on this input advances the motor one increment. The size of the increment is dependent on the microstep select inputs.
10	FAULT OUTPUT	This totem-pole output indicates a short circuit has occurred or a low signal was detected on the Fault input. This output is active high.
11	ON FULL STEP OUTPUT	This totem-pole output indicates when the driver is positioned at a full step. This output can be used to count the number of full steps the motor has moved, regardless of the number of microsteps in between. This output is active high.
12	+V	Supply voltage input.
13	SUPPLY GROUND	Supply voltage ground (return).
14	CURRENT REFERENCE	Phase current reference output. A resistor is connected between this 1 mA current source output and the Ground pin (pin 13) to generate the voltage used to set the peak phase current in the motor.
15	CURRENT REDUCTION ADJUSTMENT	Phase current reduction adjustment input. A resistor connected between this pin and pin 14 will proportionately reduce current in both windings 0.5 seconds after the last positive edge of the step clock input.

Table B.2: Pin Assignment and Description

## Mounting the INT-481 Interface Board

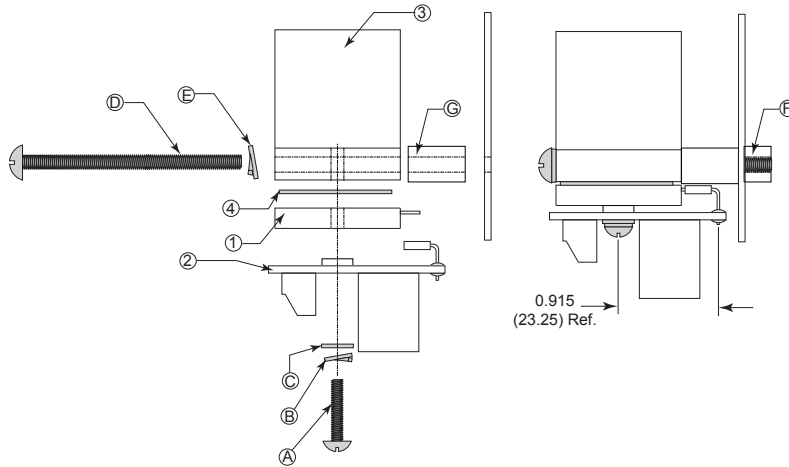

Figure B.3: IM481H Plus Panel Mount with Heat Sink

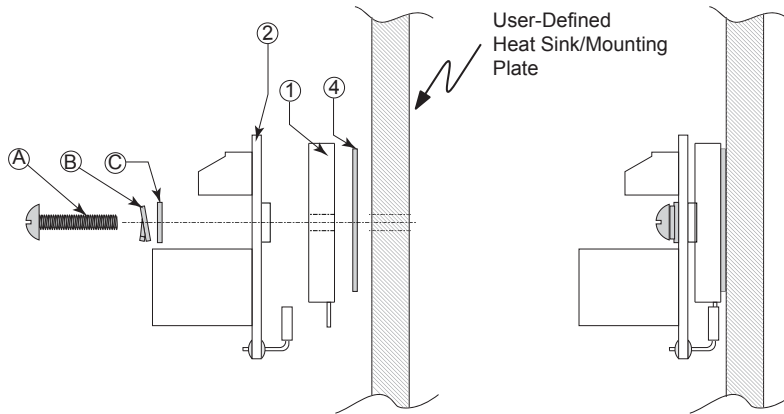

Figure B.4: IM481H Plus Panel Mount without Heat Sink

Product/Item#	Description	Qty
1	IM481H Plus Microstepping Driver	1
2	INT-481 Interface Board	1
3	H-481 Heat Sink	1
4	T1-481 Isolating Thermal Pad	1
A	#6-32x5/8" Pan Head Screw	2
B	#6 Split Lock Washer	2
C	#6 Flat Washer, 0.250" OD, 0.145" ID, 0.030" Thick	2
D	#8-32x2" Pan Head Screw	2
E	#8 Split Lock Washer	
F	#8-32 Internally Threaded Broaching Nut	
G	Spacer, 0.312" OD, 0.171" ID, 0.500" Long	

Table B.3: H-481 Heat Sink Mounting Hardware

## Recommended Wiring

Logic level cables must not run parallel to power cables. Power cables will introduce noise into the logic level cables and make your system unreliable.

Logic level cables must be shielded to reduce the chance of EMI induced noise. The shield needs to be grounded at the signal source to AC ground. The other end of the shield must not be tied to anything, but allowed to float. This allows the shield to act as a drain.

Motor cabling in excess of 1 foot requires twisted pair shielded cable to reduce the transmission of EMI. The shield must be connected to AC ground at the driver. The other end of the shield must not be tied to anything, but allowed to float. This allows the shield to act as a drain.

Power supply leads to the driver need to be twisted. If more than one driver is to be connected to the same power supply, run separate power and ground leads from the supply to each driver.

Refer to the IM481H operating instructions for recommended motor and power supply cables.

## Rules of Wiring and Shielding

Noise is always present in a system that involves both high power and small signal circuitry. Regardless of the power configuration used for your system, there are some wiring and shielding rules that should be followed to keep the noise to signal ratio as small as possible.

### Rules of Wiring

- Power supply and motor wiring should be shielded twisted pairs run separately from signal carrying wires.
- A minimum of 1 twist per inch is recommended.
- Motor wiring should be shielded twisted pairs using 20 AWG wire or, for distance greater than 5 feet, 18 gauge or better.
- Power ground return should be as short as possible to established ground.
- Power supply wiring should be shielded twisted pairs. Use 18 gauge wire if load is less than 4 amps, or 16 gauge for more than 4 amps.
- Do not “Daisy-Chain” power wiring to system components.

### Rules of Shielding

- The shield must be tied to zero-signal reference potential. In order for shielding to be effective, it is necessary for the signal to be earthed or grounded.
- Do not assume that earth ground is true earth ground. Depending on the distance to the main power cabinet, it may be necessary to sink a ground rod at a critical location.
- The shield must be connected so that shield currents drain to signal-earth connections.
- The number of separate shields required in a system is equal to the number of independent signals being processed plus one for each power entrance.
- The shield should be tied to a single point to prevent ground loops.
- A second shield can be used over the primary shield, however, the second shield is tied to ground at both ends.

## Configuration and Interface

### Output Current Adjust/Current Reduction

The INT-481 utilizes the IM481H's internal current source to adjust the Output Current of the IM481H. To calculate both the Run Current and the Reduced Current\*\* (hold) refer to the IM481H instruction manual. The figure below shows the resistor connections for both run and hold currents.

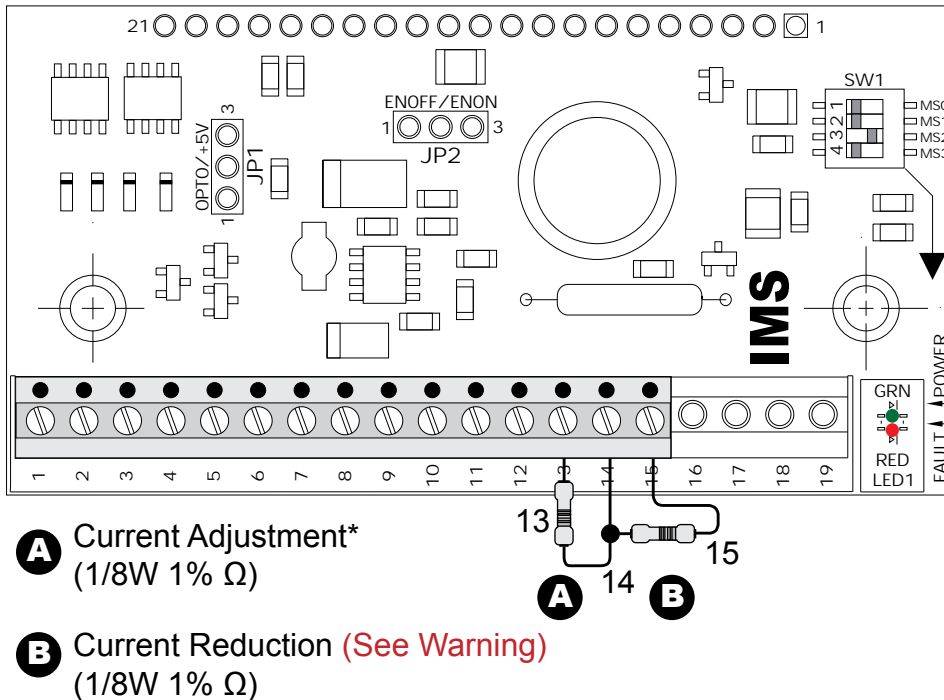

Figure B.5: INT-481H Current Adjust and Reduction Resistor Connection

\*When connecting both the current reference and current reduction resistors, connections should be made as short as possible to minimize the noise coupled into the driver. For Current Adjust Resistor values see Table 6.1 in Section 6.

### Optically Isolated Inputs

The INT-481 features four optically isolated inputs which operate at a recommended voltage range of +5 to +24 VDC. these are:

1. Step Clock
2. CW/CCW Direction
3. Enable
4. Reset

The Optocouplers may be powered by an external +5 to +24 VDC supply to allow for ease of interface to a PLC or +5 to +24V control device, or by the internal +5 VDC supply by placing Jumper JP1 in the +5V (2-3) position.

Please note that if you use the internal +5 VDC supply voltage, you defeat the optical isolation as the ground of the onboard +5 VDC is common with power ground.

If using an external optocoupler supply, connect the supply ground to the ground of your control circuitry/ device.

**WARNING!** When using the "ENON" mode of disabling the outputs following a move the current reduction resistor **MUST NOT** be used or the drive will operate erratically.

**N** NOTE: When connecting both the current adjust and the current reduction resistors, connections should be made as short as possible to minimize the amount of electrical noise coupled into the driver.

**N** NOTE: When using the on-board +5VDC supply (JP1:2-3) to power the opto-isolators, electrical isolation between drive power and the logic inputs is defeated!

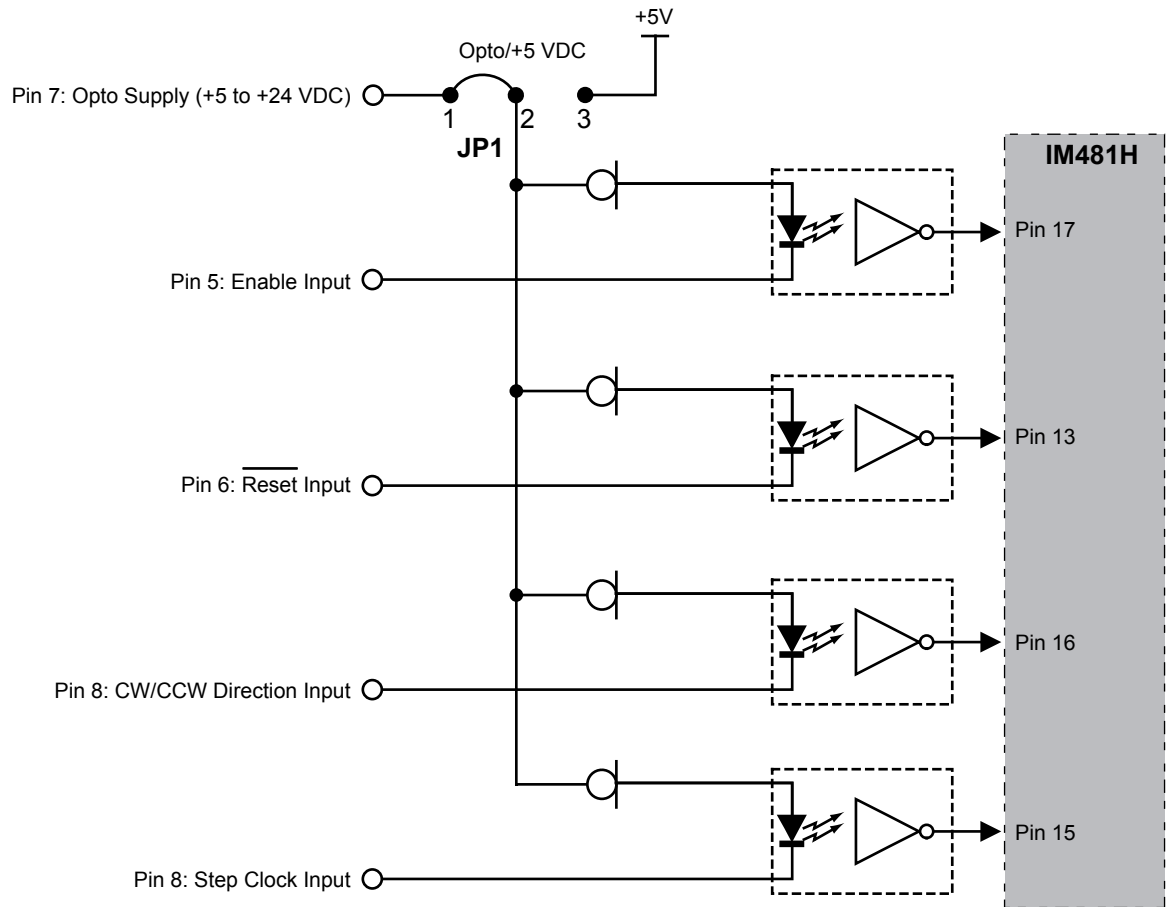

Figure B.6: INT-481H Optically Isolated Inputs

### Jumper JP1:

If the shunt is placed on the “OPTO” side of the jumper the power for the Opto Isolators must be provided by the user at Pin 7 on the P1 connector. If the shunt is placed on the “+5V” side of the jumper then the Opto Isolators will be powered by the

on-board supply and electrical isolation between the inputs and the drive power will be eliminated.

### Jumper JP2:

If the shunt is placed on the “ENON” side of the jumper then the drive outputs will be automatically disabled approximately 0.5 seconds after the last step clock input. No Reduction Adjust resistor is required or desired.

NOTE: In this mode the current reduction resistor MUST NOT be used or it will cause erratic operation of the driver. If the shunt is placed on the “ENOFF” side of the jumper then a current reduction resistor may be used to set the level of current in the motor after the last step clock input.

See Figure B.5 for Jumper placement.

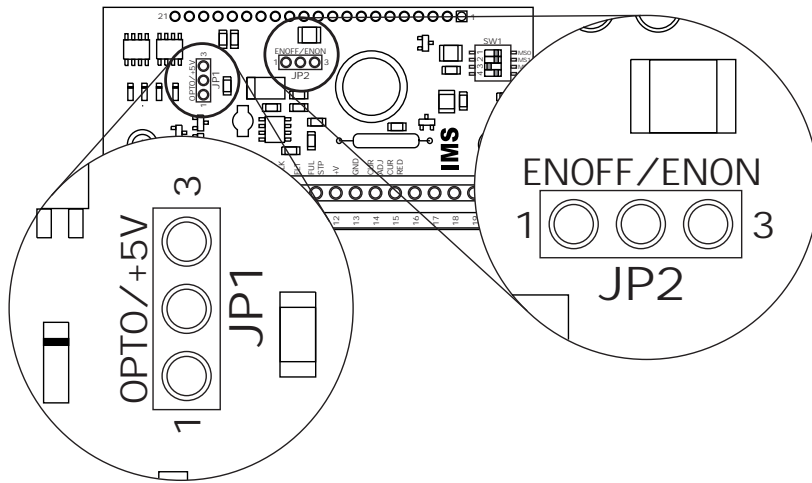

Figure B.7: Jumper JP1 and JP2 Placement and Orientation.

### LED Indicators

The green LED is controlled by the on-board +5VDC power supply.

The red LED is controlled by the Fault Output of the IM481H. If the red LED is illuminated turn off power and check for a system fault.

A fault may be caused by a short or incorrect wiring of the motor or power supply. A fault condition can only be reset by cycling power or toggling of the Reset Input on P1 Pin 6. In the case of an over temperature fault allow the drive to cool before re-applying power.

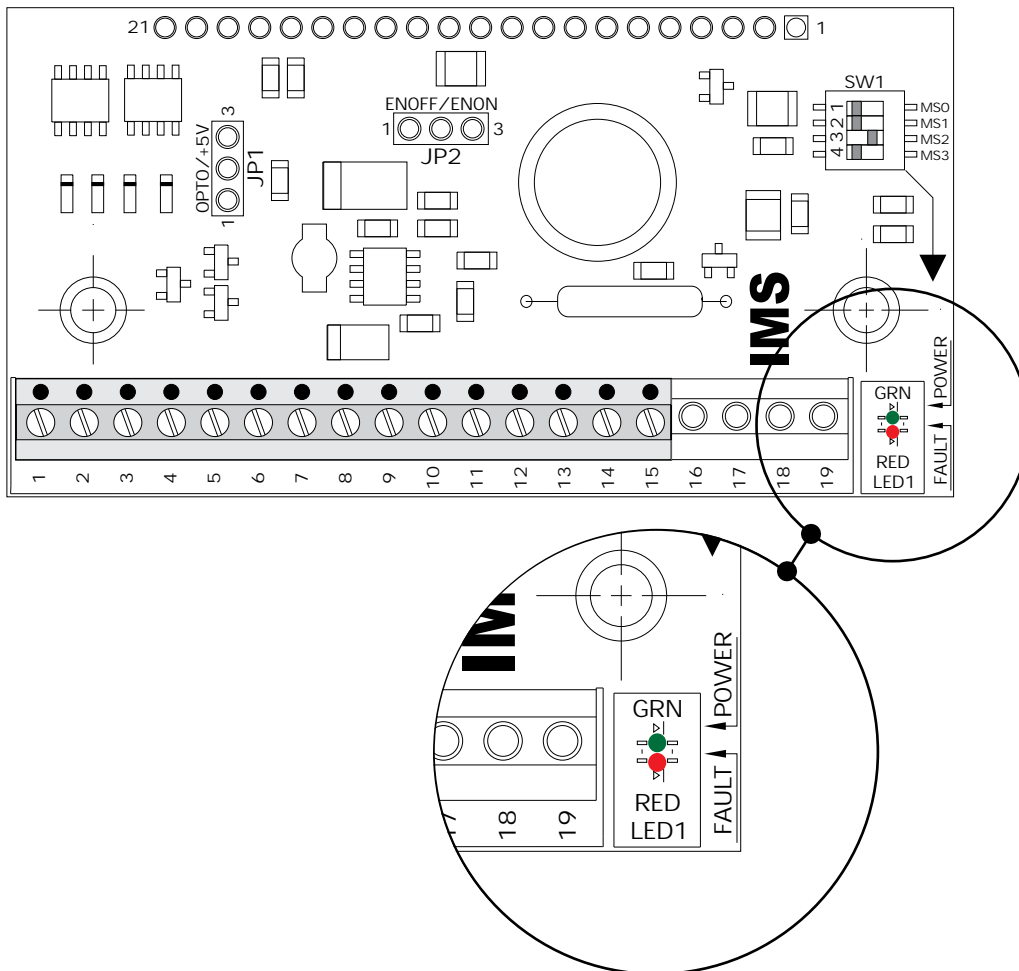

Figure B.8: Power and Fault LED Indicators.

### Fault Protection

The INT-481 adds phase to ground fault protection to the IM481H. If a phase to ground fault is detected the IM481H will latch the signal, set the Fault Output and illuminate the red Fault LED. To clear the fault condition, the IM481H will have to be Reset or power will need to be cycled.

The INT-481 buffers the IM481H Fault Output signal through an open drain N-channel FET. The signal at the terminal strip is inverted and is active LOW.

In the case of an over temperature fault, neither the red LED or the Fault Output become activated. The IM481H's motor outputs will disable. They will not re-enable until the drive cools to a safe operating level.

### Full Step Output

The INT-481 buffers the IM481H Full Step Output through an open drain N-channel FET. The signal available at the terminal strip is inverted and is active low. Reset or Power Up = Full Step.

### Microstep Resolution Selection

The number of microsteps per step is selected by the dip switch (SW1). The following table shows the standard resolution values along with the associated switch settings.

Microstep Resolution (MSEL) Settings					
RESOLUTION (Microsteps/Step)	STEPS/REV (1.8° Step Motors)	MSEL 0 (P1:5)	MSEL 1 (P1:6)	MSEL 2 (P1:7)	MSEL 3 (P1:8)
BINARY					
2	400	OFF	OFF	OFF	OFF
4	800	ON	OFF	OFF	OFF
8	1,600	OFF	ON	OFF	OFF
16	3,200	ON	ON	OFF	OFF
32	6,400	OFF	OFF	ON	OFF
64	12,800	ON	OFF	ON	OFF
128	25,600	OFF	ON	ON	OFF
256	51,200	ON	ON	ON	OFF
DECIMAL					
5	1,000	OFF	OFF	OFF	ON
10	2,000	ON	OFF	OFF	ON
25	5,000	OFF	ON	OFF	ON
50	10,000	ON	ON	OFF	ON
125	25,000	OFF	OFF	ON	ON
250	50,000	ON	OFF	ON	ON
FULL STEP					
1	200	OFF	ON	ON	ON
DEGREES					
180	36,000	ON	ON	ON	ON

Table B.4: Microstep Resolution Switch Settings

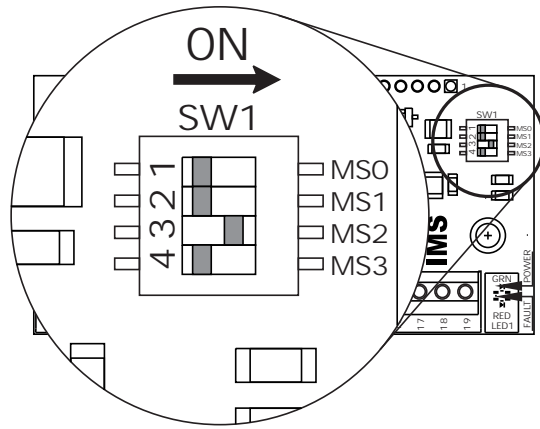

Figure B.9: Microstep Resolution Select Switch

### Minimum Required Connections

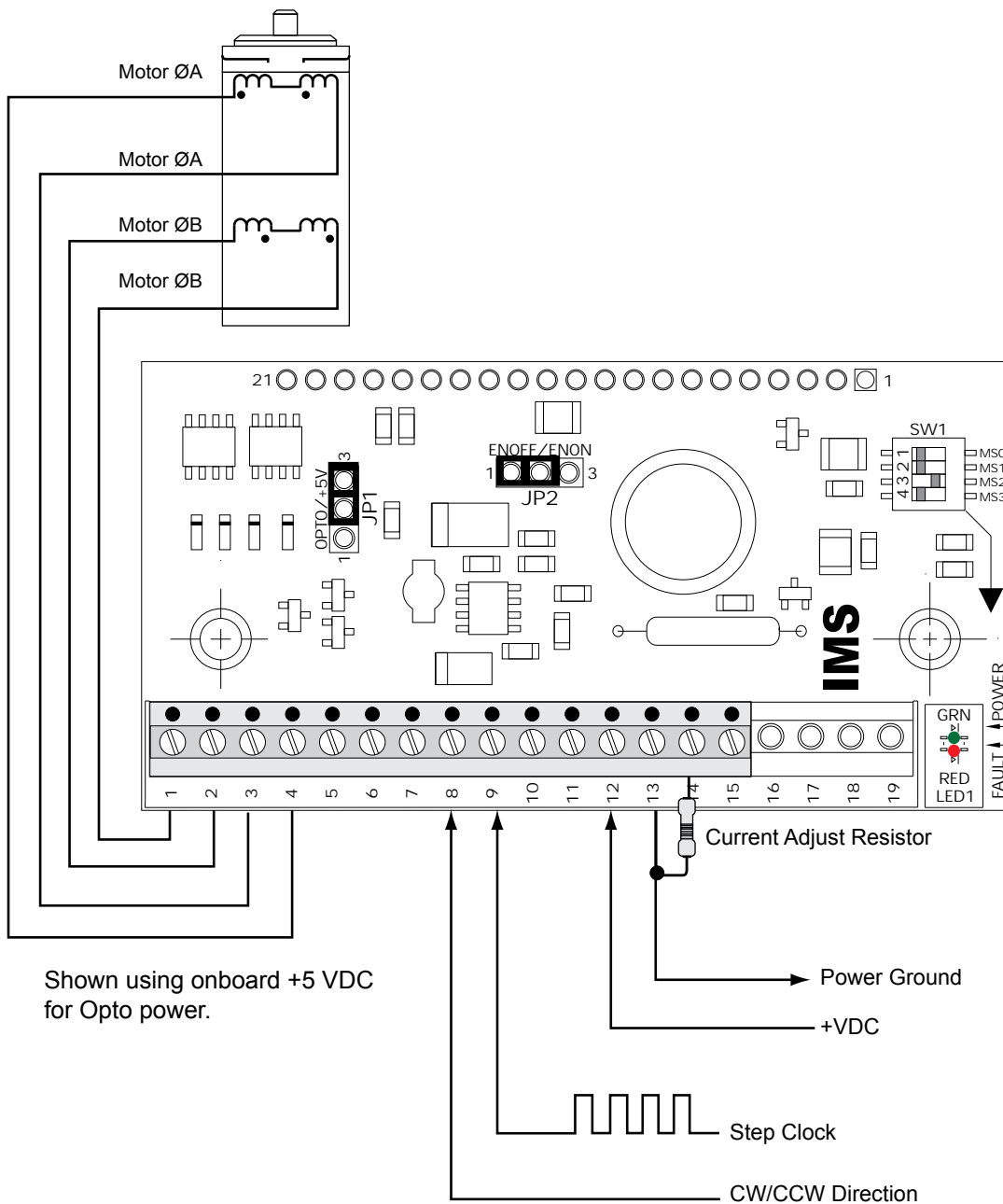

Figure B.10: Minimum Required Connections

# Appendix C

## Recommended Cable Configurations

**N** NOTE: These recommendations will provide optimal protection against EMI and RFI. The actual cable type, wire gauge, shield type and filtering devices used are dependent on the customer's application and system.

**N** NOTE: Always use Shielded/Twisted Pairs for the Novanta IMS Driver DC Supply Cable, the AC Supply Cable and the Novanta IMS Driver to Motor Cable.

### DC Power To IMS Driver

Cable length, wire gauge and power conditioning devices play a major role in the performance of your Novanta IMS Driver and Motor.

NOTE: The length of the DC power supply cable to the Novanta IMS Driver should not exceed 50 feet.

Example A demonstrates the recommended cable configuration for DC power supply cabling under 50 feet long. If cabling of 50 feet or longer is required, the additional length may be gained by adding an AC power supply cable (see Examples B & C).

Correct AWG wire size is determined by the current requirement plus cable length. Please see the Novanta IMS Driver Supply Cable AWG Table in this Appendix.

### Example A – Cabling Under 50 Feet, DC Power

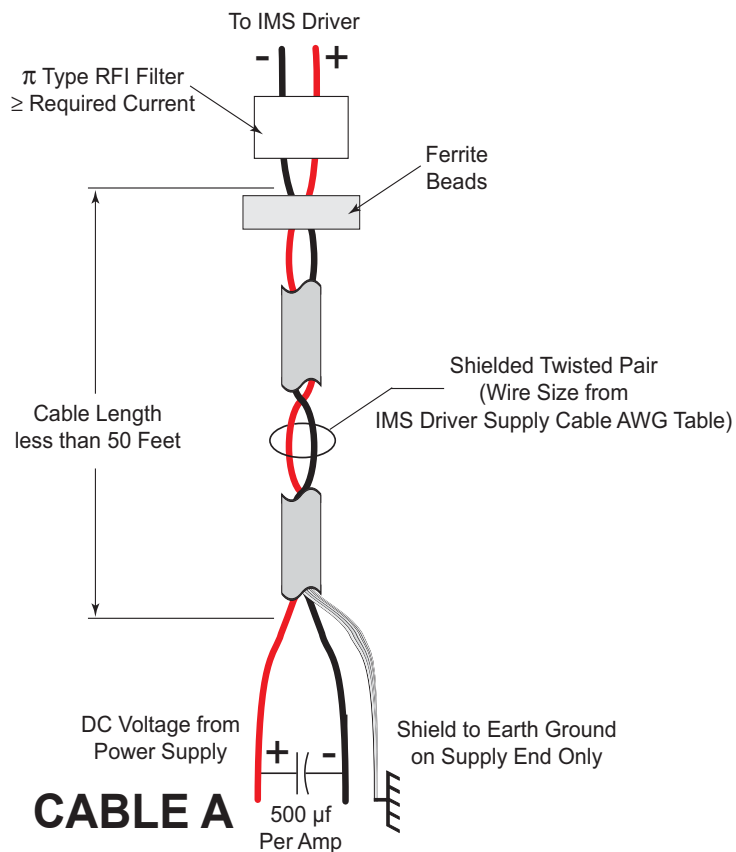

Figure C.1: DC Cabling Under 50 Feet

**Example B – Cabling 50 Feet or Greater, AC Power to Full Wave Bridge**

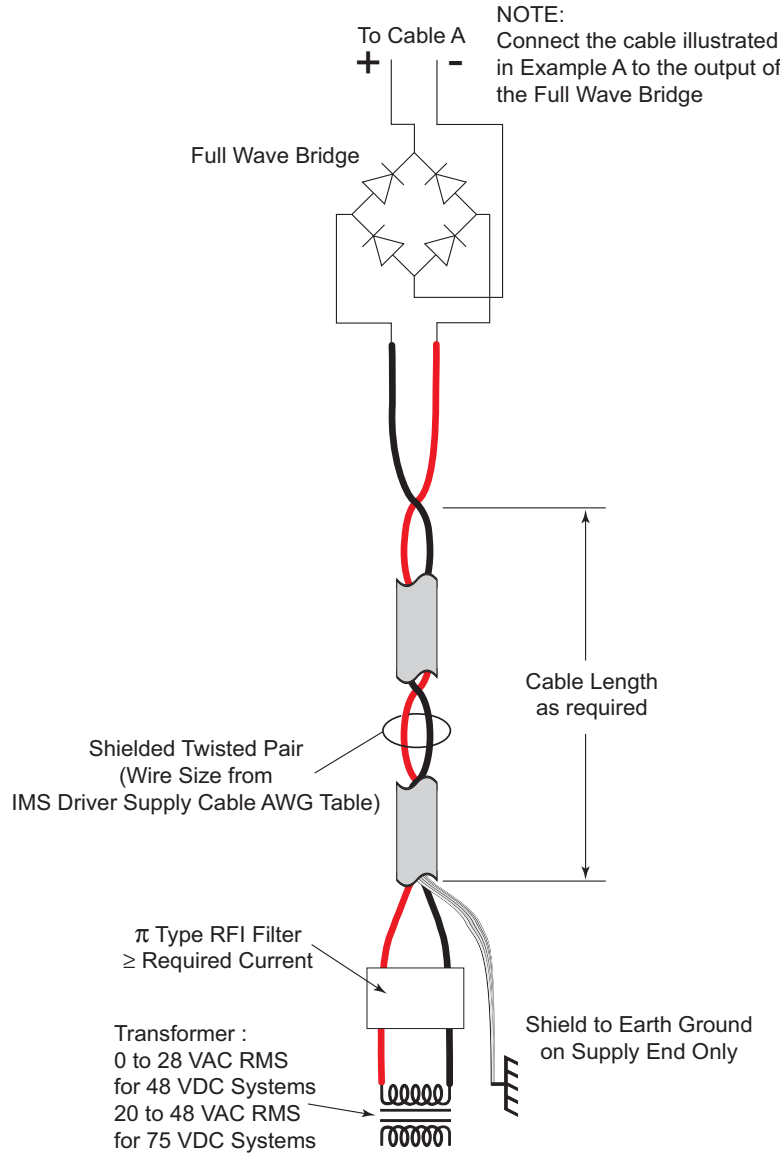

Figure C.2: Cabling 50 Feet or Greater, AC Power to Full Wave Bridge

### Example C – Cabling 50 Feet or Greater, AC Power to Power Supply

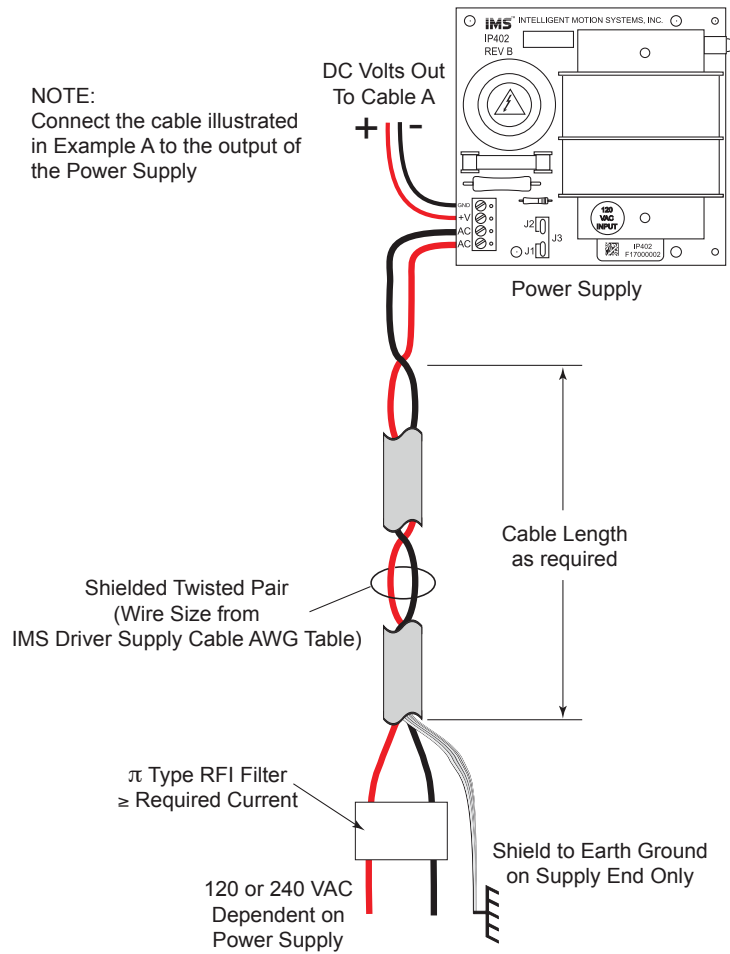

Figure C.3: Cabling 50 Feet or Greater, AC Power to Motor Power Supply

Novanta IMS Driver Supply Cable AWG Table					
1 Ampere (Peak)					
Length (Feet)	10	25	50*	75*	100*
Minimum AWG	20	20	18	18	16
2 Amperes (Peak)					
Length (Feet)	10	25	50*	75*	100*
Minimum AWG	20	18	16	14	14
3 Amperes (Peak)					
Length (Feet)	10	25	50*	75*	100*
Minimum AWG	18	16	14	12	12
4 Amperes (Peak)					
Length (Feet)	10	25	50*	75*	100*
Minimum AWG	18	16	14	12	12
* Use the alternative methods innustrated in Examples B and C when the cable length is $\geq$ 50 feet. Also, use the same current rating when the alternate AC power is used.					

Table C.1: Driver Supply Cable Wire Size

## Motor Driver to Motor

Cable length, wire gauge and power conditioning devices play a major role in the performance of your Novanta IMS Driver and Motor.

NOTE: The length of the DC power supply cable between the Novanta IMS Driver and the Motor should not exceed 50 feet.

Example A demonstrates the recommended cable configuration for the Novanta IMS Driver to Motor cabling under 50 Feet long. If cabling of 50 feet or longer is required, the additional length can be gained with the cable configuration in Example B.

Correct AWG wire size is determined by the current requirement plus cable length. Please see the Novanta IMS Driver to Motor Cable AWG Table in this Appendix.

### Example A - Cabling Under 50 Feet, Novanta IMS Driver to Motor

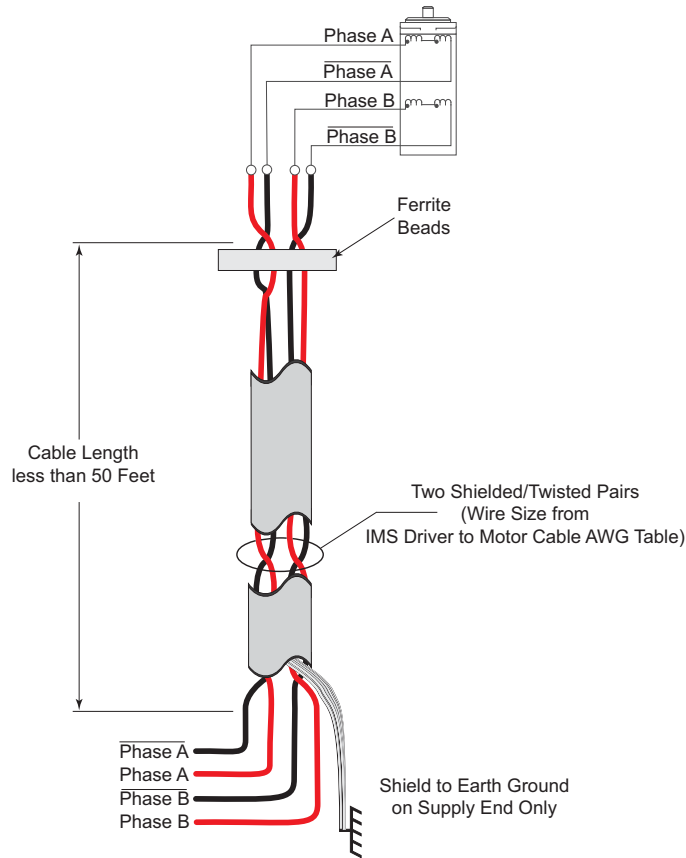
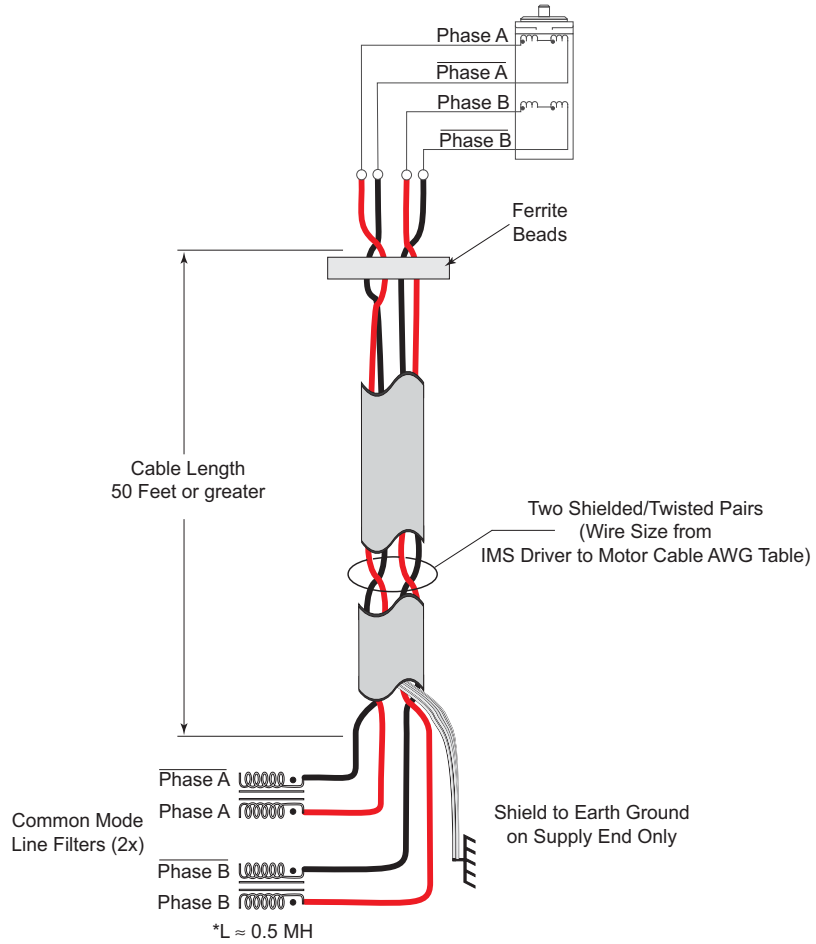

Figure C.4: Cabling Under 50 Feet, Novanta IMS Driver to Motor

Example B - Cabling 50 Feet or Greater, IMS Driver to Motor



\* 0.5 MH is a typical starting point for the Common Mode Line Filters. By increasing or decreasing the value of L you can set the drain current to a minimum to meet your requirements.

Figure C.5: Cabling Under 50 Feet, Novanta IMS Driver to Motor

Novanta IMS Driver to Motor Cable AWG Table											
1 Ampere (Peak)					5 Amperes (Peak)						
Length (Feet)	10	25	50*	75*	100*	Length (Feet)	10	25	50*	75*	100*
Minimum AWG	20	20	18	18	16	Minimum AWG	16	16	14	12	12
2 Amperes (Peak)					6 Amperes (Peak)						
Length (Feet)	10	25	50*	75*	100*	Length (Feet)	10	25	50*	75*	100*
Minimum AWG	20	18	16	14	14	Minimum AWG	14	14	14	12	12
3 Amperes (Peak)					7 Amperes (Peak)						
Length (Feet)	10	25	50*	75*	100*	Length (Feet)	10	25	50*	75*	100*
Minimum AWG	18	16	14	12	12	Minimum AWG	12	12	12	12	12
4 Amperes (Peak)											
Length (Feet)	10	25	50*	75*	100*	* Use the alternate method illustrated in Example B when cable length is ≥ 50 feet.					
Minimum AWG	18	16	14	12	12						

Table C.2: Driver Supply Cable Wire Size

# Appendix D

## Application and Usage Examples

### Electronic "Gear Shifting"

Electronic Gear Shifting applications use the IM481H Plus ability to change the Microstep Resolution on the fly. Using solid state outputs of a PLC or other control device allows the system to "Shift Gears" by changing the state of the Microstep Resolution Select inputs (MSEL 0 - 3).

In the example shown below, the control device will change the microstep resolution from 256  $\mu$ steps/step to 128  $\mu$ steps/step, doubling the motor velocity.

Note: Use solid state, not mechanical switching.

Note 2: The below diagram is for illustration purposes only, additional circuitry may be required between your control interface and the IM481H Plus Product.

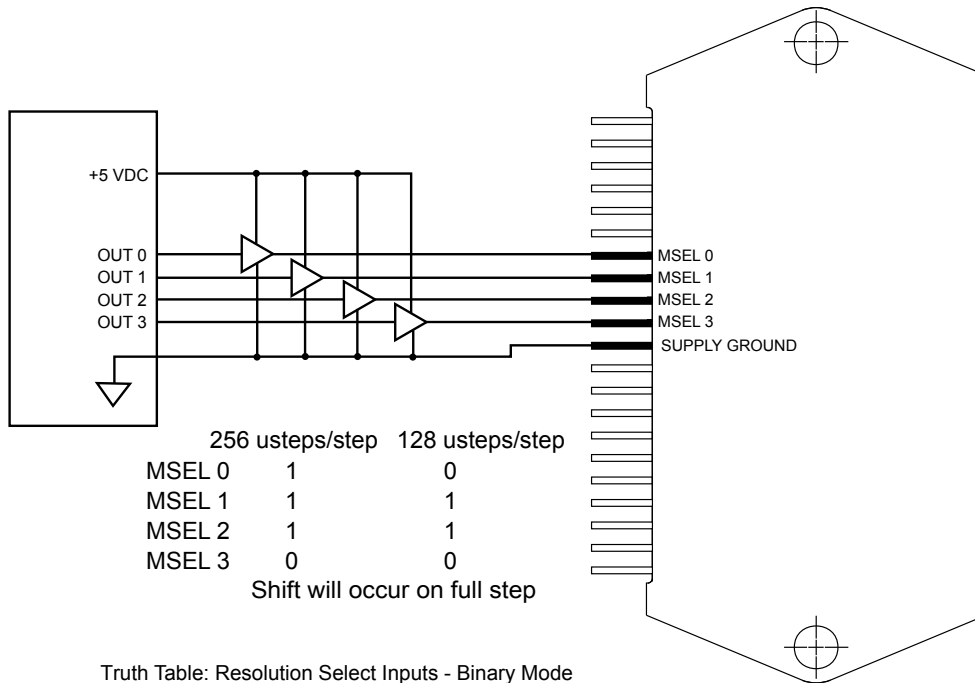

Truth Table: Resolution Select Inputs - Binary Mode

Microsteps per Full Step	MSEL 0	MSEL 1	MSEL 2	MSEL 3
2	0	0	0	0
4	1	0	0	0
8	0	1	0	0
16	1	1	0	0
32	0	0	1	0
64	1	0	1	0
128	0	1	1	0
256	1	1	1	0

Truth Table: Resolution Select Inputs - Decimal Mode

Microsteps per Full Step	MSEL 0	MSEL 1	MSEL 2	MSEL 3
5	0	0	0	1
10	1	0	0	1
25	0	1	0	1
50	1	1	0	1
125	0	0	1	1
250	1	0	1	1

Additional Microstep Resolution Settings

Microsteps per Full Step	MSEL 0	MSEL 1	MSEL 2	MSEL 3
1 (Full Step)	0	1	1	1
180 (Degrees)	1	1	1	1

Figure D.1: Electronic Gear Shifting Application Example

## Using The Full Step Output to Show Axis Position

The IM481H Plus features an On-Full-Step output. This totem-pole output will send a HIGH Pulse when the motor is positioned at Full Step regardless of the number of microsteps in between.

The below application example illustrates a simple counter system that would track the position of the axis in Full Steps. The state of the Direction input will determine the up/down state of the counter.

The below diagram is for illustration purposes only, additional circuitry may be required between your control interface and the IM481H Plus Product.

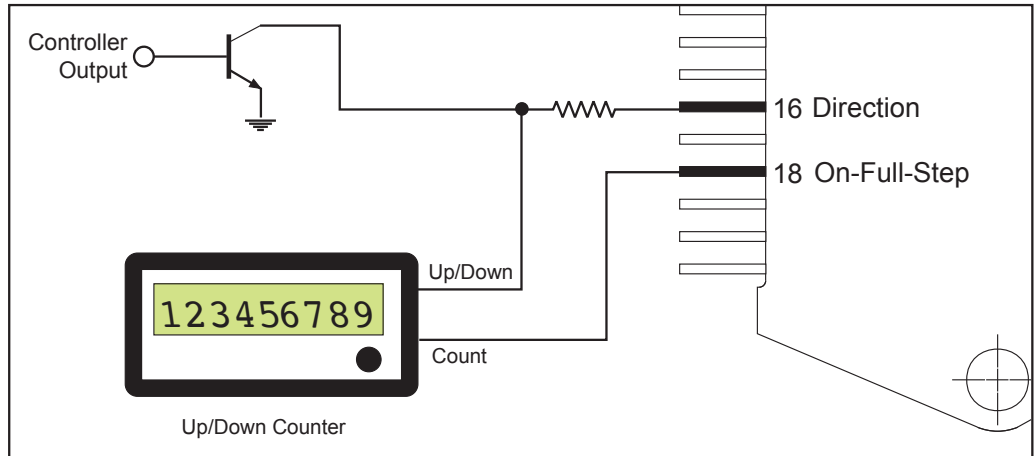

Figure D.2: On-Full-Step Position Counter

# WARRANTY

## TWENTY-FOUR (24) MONTH LIMITED WARRANTY

Novanta IMS warrants only to the purchaser of the Product from Novanta IMS (the "Customer") that the product purchased from Novanta IMS (the "Product") will be free from defects in materials and workmanship under the normal use and service for which the Product was designed for a period of 24 months from the date of purchase of the Product by the Customer. Customer's exclusive remedy under this Limited Warranty shall be the repair or replacement, at Company's sole option, of the Product, or any part of the Product, determined by Novanta IMS to be defective. In order to exercise its warranty rights, Customer must notify Company in accordance with the instructions described under the heading "Obtaining Warranty Service".

*NOTE: MDrive Motion Control electronics are not removable from the motor in the field. The entire unit must be returned to the factory for repair.*

This Limited Warranty does not extend to any Product damaged by reason of alteration, accident, abuse, neglect or misuse or improper or inadequate handling; improper or inadequate wiring utilized or installed in connection with the Product; installation, operation or use of the Product not made in strict accordance with the specifications and written instructions provided by Novanta IMS; use of the Product for any purpose other than those for which it was designed; ordinary wear and tear; disasters or Acts of God; unauthorized attachments, alterations or modifications to the Product; the misuse or failure of any item or equipment connected to the Product not supplied by Novanta IMS; improper maintenance or repair of the Product; or any other reason or event not caused by Novanta IMS.

NOVANTA IMS HEREBY DISCLAIMS ALL OTHER WARRANTIES, WHETHER WRITTEN OR ORAL, EXPRESS OR IMPLIED BY LAW OR OTHERWISE, INCLUDING WITHOUT LIMITATION, ANY WARRANTIES OF MERCHANTABILITY OR FITNESS FOR ANY PARTICULAR PURPOSE. CUSTOMER'S SOLE REMEDY FOR ANY DEFECTIVE PRODUCT WILL BE AS STATED ABOVE, AND IN NO EVENT WILL NOVANTA IMS BE LIABLE FOR INCIDENTAL, CONSEQUENTIAL, SPECIAL OR INDIRECT DAMAGES IN CONNECTION WITH THE PRODUCT.

This Limited Warranty shall be void if the Customer fails to comply with all of the terms set forth in this Limited Warranty. This Limited Warranty is the sole warranty offered by Novanta IMS with respect to the Product. Novanta IMS does not assume any other liability in connection with the sale of the Product. No representative of Novanta IMS is authorized to extend this Limited Warranty or to change it in any manner whatsoever. No warranty applies to any party other than the original Customer.

Novanta IMS and its directors, officers, employees, subsidiaries and affiliates shall not be liable for any damages arising from any loss of equipment, loss or distortion of data, loss of time, loss or destruction of software or other property, loss of production or profits, overhead costs, claims of third parties, labor or materials, penalties or liquidated damages or punitive damages, whatsoever, whether based upon breach of warranty, breach of contract, negligence, strict liability or any other legal theory, or other losses or expenses incurred by the Customer or any third party.

### **OBTAINING WARRANTY SERVICE**

If the Product was purchased from a Novanta IMS Distributor, please contact that Distributor to obtain a Returned Material Authorization (RMA). If the Product was purchased directly from Novanta IMS, please contact Customer Service at [custservicegroup@novantaims.com](mailto:custservicegroup@novantaims.com) or 860-295-6102 (Eastern Time Zone).

Customer shall prepay shipping charges for Products returned to Novanta IMS for warranty service and Novanta IMS shall pay for return of Products to Customer by ground transportation. However, Customer shall pay all shipping charges, duties and taxes for Products returned to Novanta IMS from outside the United States.

**Novanta IMS**  
370 N. Main Street  
Marlborough, CT 06447  
860-295-6102  
[www.novantaims.com](http://www.novantaims.com)

© Novanta IMS All Rights Reserved. *Product Disclaimer and most recent product information at [www.novantaims.com](http://www.novantaims.com).*

REV060123

