

IM483H Plus & IM805H Plus

High performance ultra-miniature microstepping drivers



Change Log		
Date	Revision	Changes
07/13/2006	R071306	Change Temperature Spec to -40 to +85 deg. C, Changed Quiescent current spec from 40 to 150mA, max step clock rate from 10MHz to 5 MHz, Step clock response time from 100 to 650nS, MSEL setup time from 100 nS to 4 mS, zero crossing response from 75 to 650 nS. Added notes concerning Fault condition on power up or reset and 150mA quiescent current. Added two new Microstep Resolutions, Full Step and Degrees.
01/26/2007	R012607	Added note about Phase reversal between IM483H and IM805H Plus Hybrids on Phase A.
03/12/2007	R031207	Changed max Step Frequency to 2.5 MHz, Min Step pulse width to 200 nS. Added CE and RoHS compliance logos. Clarification on pin description Table 2.5 page 7.
01/22/2008	R012208	Changed Solder recommendation to a SAC305 (Sn96.5Ag3.0Cu0.5) lead free solder for RoHS compliant circuit board manufacture.
03/30/2010	R033010	Changes to warranty, disclaimer, conditions for use and address information
06/01/2023	R060123	Rebrand to Novanta IMS

The information in Novanta IMS product manuals and on this web site has been carefully checked and is believed to be accurate; however, no responsibility is assumed for inaccuracies.

Novanta IMS reserves the right to make changes without further notice to any products to improve reliability, function or design. Novanta IMS does not assume any liability arising out of the application or use of any product or circuit described; neither does it convey any license under its patent rights of others.

Novanta IMS's general policy does not recommend the use of its products in life support or aircraft applications wherein a failure or malfunction of the product may directly threaten life or injury. Per Novanta IMS's terms and conditions of sales, the user of Novanta IMS products in life support or aircraft applications assumes all risks of such use and indemnifies Novanta IMS against all damages.

Important information

The drive systems described here are products for general use that conform to the state of the art in technology and are designed to prevent any dangers. However, drives and drive controllers that are not specifically designed for safety functions are not approved for applications where the functioning of the drive could endanger persons. The possibility of unexpected or un-braked movements can never be totally excluded without additional safety equipment. For this reason personnel must never be in the danger zone of the drives unless additional suitable safety equipment prevents any personal danger. This applies to operation of the machine during production and also to all service and maintenance work on drives and the machine. The machine design must ensure personal safety. Suitable measures for prevention of property damage are also required.

Qualification of personnel

Only technicians who are familiar with and understand the contents of this manual and the other relevant documentation are authorized to work on and with this drive system. The technicians must be able to detect potential dangers that may be caused by setting parameters, changing parameter values and generally by the operation of mechanical, electrical and electronic equipment.

The technicians must have sufficient technical training, knowledge and experience to recognise and avoid dangers.

The technicians must be familiar with the relevant standards, regulations and safety regulations that must be observed when working on the drive system.

Intended Use

The drive systems described here are products for general use that conform to the state of the art in technology and are designed to prevent any dangers. However, drives and drive controllers that are not specifically designed for safety functions are not approved for applications where the functioning of the drive could endanger persons. The possibility of unexpected or unbraked movements can never be totally excluded without additional safety equipment.

For this reason personnel must never be in the danger zone of the drives unless additional suitable safety equipment prevents any personal danger. This applies to operation of the machine during production and also to all service and maintenance work on drives and the machine. The machine design must ensure personal safety. Suitable measures for prevention of property damage are also required.

In all cases the applicable safety regulations and the specified operating conditions, such as environmental conditions and specified technical data, must be observed.

The drive system must not be commissioned and operated until completion of installation in accordance with the EMC regulations and the specifications in this manual. To prevent personal injury and damage to property damaged drive systems must not be installed or operated.

Changes and modifications of the drive systems are not permitted and if made all no warranty and liability will be accepted.

The drive system must be operated only with the specified wiring and approved accessories. In general, use only original accessories and spare parts.

The drive systems must not be operated in an environment subject to explosion hazard (ex area).

This page intentionally left blank

Table of Contents

Section 1: Introduction	1
The IM483H Plus/IM805H Plus Hybrid	1
Features and Benefits	1
<i>IM483H Plus/IM805H Plus</i>	1
The Product Manual	2
Symbols Used In This Document	2
Notes and Warnings	2
Section 2: Hardware Specifications	3
Section Overview	3
Mechanical Specifications	3
<i>Dimensional Information - IM483H Plus/IM805H Plus</i>	3
Thermal Specifications	4
Electrical Specifications	5
<i>IM483H Plus DC Electrical Characteristics</i>	5
<i>IM805H Plus DC Electrical Characteristics</i>	6
Pin Assignment and Description	7
Section 3: Mounting the IM483H Plus/IM805H Plus	9
Section Overview	9
Mounting the IM483H Plus/IM805H Plus	9
<i>Direct Mounting the IM483H Plus/IM805H Plus to a PC Board</i>	9
<i>Mounting the IM483H Plus/IM805H Plus Using the PR-22 Receptacle</i>	10
<i>Recommended Mounting Hardware</i>	10
<i>Attaching the HFC-22 Heat Sink/Fan/Clip Assembly</i>	11
<i>Removing the HFC-22 Heat Sink/Fan/Clip Assembly</i>	11
Section 4: Power Supply Requirements	12
Section Overview	12
Selecting a Power Supply	12
<i>Selecting a Motor Supply (+V)</i>	12
<i>Recommended Novanta IMS Power Supplies</i>	13
Recommended Wiring	14
<i>Rules of Wiring and Shielding</i>	14
AC Line Filtering	14
Section 5: Motor Requirements	15
Section Overview	15
Selecting a Motor	15
<i>Types and Construction of Stepping Motors</i>	15
<i>Sizing a Motor for Your System</i>	15
<i>Connecting the Motor</i>	18
<i>IM483H Plus/IM805H Plus</i>	18
<i>8 Lead Motors</i>	18
<i>6 Lead Motors</i>	19
<i>4 Lead Motors</i>	19
Section 6: Interfacing to the IM483H Plus/IM805H Plus	20
Section Overview	20
Layout and Interface Guidelines	20
Motor Power	20
+5 VDC Input	21
Interfacing the Current Adjust Input	21
<i>Setting the Output Current</i>	22
<i>Current Adjust Resistor and Reference Values</i>	23
Interfacing the IM483H Plus/IM805H Plus Inputs	25
<i>The Microstep Resolution Select Inputs (MSEL)</i>	25
<i>Interfacing the Fault and Reset Inputs</i>	26
Minimum Connections	27

Appendices

Appendix A: Troubleshooting	A-1
Section Overview	A-1
Basic Troubleshooting	A-1
Common Problems and Solutions	A-1
Contacting Application Support	A-2
The Novanta IMS Web Site.....	A-2
Returning Your Product to Novanta IMS	A-2
Appendix B: The IM483H Plus/IM805H Plus Developer's Kit (-DK1)	A-3
Assembling the HFC-22 Heat Sink/Fan/Clip Assembly and Interface Board	A-3
Pin Assignment and Descriptions	A-4
Electrical Specifications	A-4
Dimensional Information.....	A-5
Setting the Output Current	A-6
Isolated Inputs	A-6
Microstep Resolution Settings	A-7
LED Indicators.....	A-8
Fault Protection	A-8
Minimum Connections for the IM483H Plus/IM805H Plus-DK1	A-9
Appendix C: Recommended Cable Configurations	A-10
Appendix D: Application and Usage Examples.....	A-15
Electronic "Gear Shifting"	A-15
Speed Control with Following on a Second Axis using the OSC-805H	A-16
Using The Full Step Output to Show Axis Position	A-16

List of Figures

Figure 2.1: IM483H Plus/IM805H Plus Dimensions	3
Figure 2.2: PR-22 Dimensions	4
Figure 2.3: IM483H Plus/IM805H Plus Step and Direction Timing Diagram	6
Figure 2.4: IM483H Plus/IM805H Plus Connectors	8
Figure 3.1: PCB Hole Pattern (Direct Mounting to a PC Board)	9
Figure 3.2: PR-22 Pin Receptacle Carrier	10
Figure 3.3: PCB Hole Pattern (for Mounting of the PR-22 Pin Receptacle Carrier)	10
Figure 3.4: PCB Mounting Hardware (Direct Mounting or Socketed)	10
Figure 3.5: HFC-22 Heat Sink/Fan/Clip Assembly	11
Figure 5.1 A & B: Per Phase Winding Inductance	16
Figure 5.2: 8 Lead Series Motor Connections	18
Figure 5.3: 8 Lead Parallel Motor Connections.....	18
Figure 5.4: 6 Lead Half Coil (Higher Speed) Motor Connections	19
Figure 5.5: 6 Lead Full Coil (Higher Torque) Motor	19
Figure 5.6: 4 Lead Motor Connections	19
Figure 6.1: Power Interface	20
Figure 6.2: Current Adjust Resistor Connection	22
Figure 6.3: Setting the Output Current using an External Source	22
Figure 6.4: Current Reduction Adjustment Resistor Connection	24
Figure 6.5: Interfacing the Current Reduction Input	24
Figure 6.6: Input Pull-Up Resistors	25
Figure 6.7: MSEL Inputs, Interface Example	26
Figure 6.8: Reset Timing	26
Figure 6.9: Interfacing the Fault In/Reset Inputs	26
Figure 6.10: Multiple Drives - One Reset	26
Figure 6.11: IM483H Plus/IM805H Plus Minimum Connections	27
Figure B.1: IM483H Plus-DK1/IM805H Plus-DK1	A-3
Figure B.2: HFC-22 Exploded View	A-3
Figure B.3: INT-483 / INT-805 Interface Board Dimensions.....	A-5
Figure B.4: INT-483 / INT-805 Current Adjustment Resistors	A-6
Figure B.5: Jumpers JP1 & JP2	A-6
Figure B.6: Opto Isolated Inputs	A-7
Figure B.7: MSEL Select Switch	A-7
Figure B.8: Minimum Connections	A-9
Figure C.1: DC Cabling Under 50 Feet.....	A-10
Figure C.2: Cabling 50 Feet or Greater, AC Power to Full Wave Bridge	A-11
Figure C.3: Cabling 50 Feet or Greater, AC Power to Motor Power Supply	A-12
Figure C.4: Cabling Under 50 Feet, Novanta IMS Driver to Motor	A-13
Figure C.5: Cabling Under 50 Feet, Novanta IMS Driver to Motor	A-14
Figure D.1: Electronic Gear Shifting Application Example	A-15
Figure D.2: Speed Control Application	A-16
Figure D.3: On-Full-Step Position Counter.....	A-16

List Of Tables

Table 2.1: IM483H Plus/IM805H Plus Thermal Specifications	4
Table 2.2: IM483H Plus DC Electrical Characteristics.....	5
Table 2.3: IM805H Plus DC Electrical Characteristics.....	6
Table 2.4: IM483H Plus/IM805H Plus Connector P1 Configuration.....	7
Table 2.5: IM483H Plus/IM805H Plus Connector P2 Configuration.....	7
Table 4.1: Motor Power Supply Specifications	13
Table 4.2: +5VDC Power Supply Specifications	13
Table 6.1: Current Adjust Reference/Output Current (IM483H Plus)	23
Table 6.2: Current Adjust Reference/Output Current (IM805H Plus)	23
Table 6.3: Microstep Resolution Select Settings.....	25
Table 6.4: Minimum Connections	27
Table B.1: INT-483 / 805 Pin Assignment and Descriptions.....	A-4
Table B.2: INT-483 / 805 Interface Board Electrical Characteristics.....	A-4
Table B.3: Microstep Resolution Switch Settings.....	A-8
Table C.1: Driver Supply Cable Wire Size	A-12
Table C.2: Driver Supply Cable Wire Size	A-14

Section 1

Introduction

The IM483H Plus/IM805H Plus Hybrid

The IM483H Plus and IM805H Plus are high performance, yet low cost microstepping drivers that utilize advanced hybrid technology to greatly reduce size without sacrificing features. The IM483H Plus and IM805H Plus are exceptionally small, easy to interface and use, yet powerful enough to handle the most demanding applications.

The IM483H Plus and IM805H Plus have 16 built-in microstep resolutions (both binary and decimal). The resolution can be changed at any time without the need to reset the driver. This feature allows the user to rapidly move long distances, yet precisely position the motor at the end of travel without the expense of high performance controllers.

With the development of proprietary and patented circuitry, ripple current has been minimized to reduce motor heating common with other designs, allowing the use of low inductance motors to improve high speed performance and system efficiency.

The IM483H Plus and IM805H Plus, because of their ultra small size and low cost, can be used to increase accuracy and smoothness in systems using higher step angle motors. In many instances mechanical gearing can be replaced with microstepping, reducing cost and eliminating potential maintenance.

Available as options for the IM483H Plus/IM805H Plus are the HFC-22 Heat Sink/Fan/Clip assembly and the PR-22 Pin Receptacle carrier. The HFC-22 provides a unique cooling solution and was designed specifically for the IM483H Plus and IM805H Plus Hybrid Microstepping Drivers. The HFC-22 will easily maintain a reliable rear plate temperature without using large heat sinks and cumbersome mounting hardware. The heat sink and fan are easily mounted to the driver by means of a removable clip developed by Novanta IMS. The HFC-22 fully assembled with the IM483H Plus or IM805H Plus takes up only 6.8 in³ of space! For applications where ease of removal is required, the PR-22 provides reliable, high quality receptacle set which comes attached to a high temperature plastic throwaway carrier that allows for ease of placement for wave or hand soldering.

The IM483H Plus and IM805H Plus were developed to provide designers with affordable, state-of-the-art technology for the competitive edge needed in today's market.

Features and Benefits

IM483H Plus/IM805H Plus

- Very Low Cost.
- Ultra Miniature 2.10" x 2.60" x 0.362"
(53.34 x 66.04 x 9.19 mm).
- Advanced Hybrid Design.
- High Input Voltage (+12 to +48VDC/+12 to +75 VDC).
- High Output Current (3A RMS, 4A Peak/5A RMS, 7A Peak).
- No Minimum Inductance.
- FAULT Input and Output.
- Phase-to-Phase Short Circuit Protection.
- Over Temperature Protection.
- Microstep Resolution to 51,200 Steps/Rev.
- Microstep Resolutions can be Changed "On-The-Fly" Without Loss of Motor Position.
- 20-60 kHz Variable Chopping Rate.
- 16 Selectable Microstep Resolutions.
- Adjustable Automatic Current Reduction.
- At Full Step Output.
- Optional Cooling Solution (HFC-22).
- Optional Receptacle Carrier (PR-22).
- Development Kit for Prototyping (DK-1).

The Product Manual

The IM483H Plus/IM805H Plus product manual in its electronic format may be downloaded from the Novanta IMS website at www.novantaims.com. This version includes a Bookmarks feature that allows the reader to link from a Book marked Topic in the Table of Contents to a full description of that feature's attributes and functions.

Symbols Used In This Document



ESD Warning: Components sensitive to Electrostatic Discharge.



Hazardous Voltage Warning: Motion systems may contain dangerous voltage levels.



Product Usage Warning: Failure to heed warnings marked with this symbol may result in damage to the device and/or system components.



Note: Indicates a usage tip for your Novanta IMS product.



Math: Indicates an equation to be used in configuring your Novanta IMS product.

Notes and Warnings



WARNING! The IM483H Plus/IM805H Plus components are sensitive to Electrostatic Discharge (ESD). All handling should be done at an ESD protected workstation.



WARNING! Hazardous voltage levels may be present if using an open frame power supply to power the IM483H Plus/IM805H Plus.



WARNING! Do not apply power to the IM483H Plus/IM805H Plus without proper heat sinking or cooling! The included thermal pad (TI-22) MUST be used between the IM483H Plus/IM805H Plus and the heat sink! The maximum rear plate temperature of the IM483H Plus/IM805H Plus is 70°C!

Section 2

Hardware Specifications

Section Overview

This section will acquaint you with the dimensional information, pin description, power, environmental and thermal requirements of the IM483H Plus/IM805H Plus. It is broken down as follows:

- Mechanical Specifications.
- Electrical Specifications.
- Thermal Specifications.
- Pin Assignment and Description.

Mechanical Specifications

Dimensional Information - IM483H Plus/IM805H Plus

Dimensions in Inches (mm)

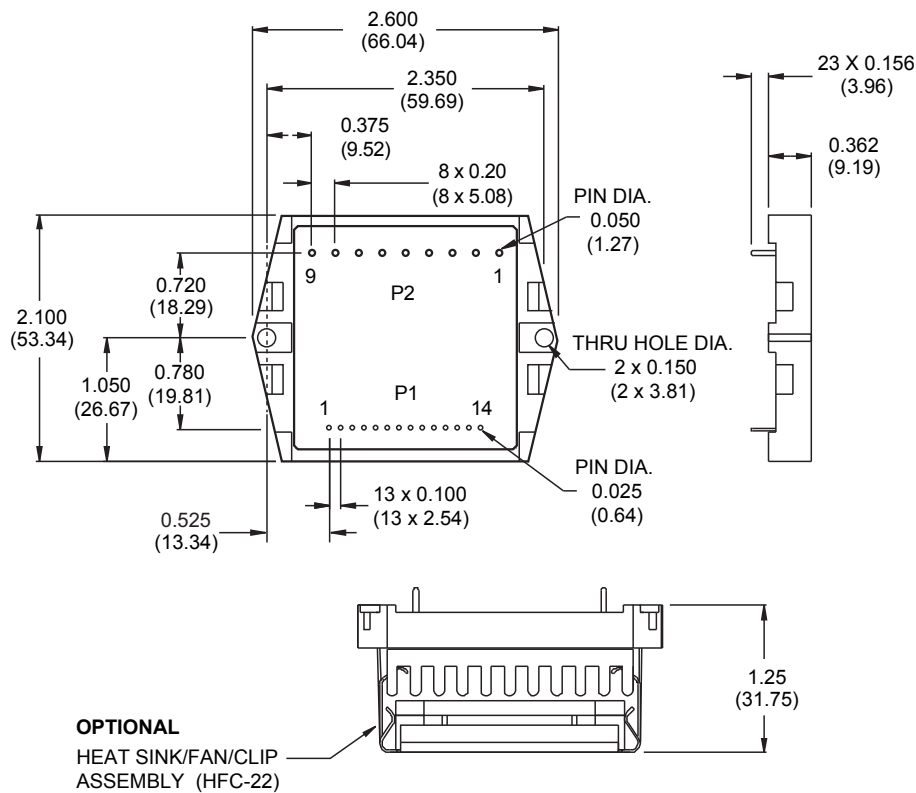

Figure 2.1: IM483H Plus/IM805H Plus Dimensions

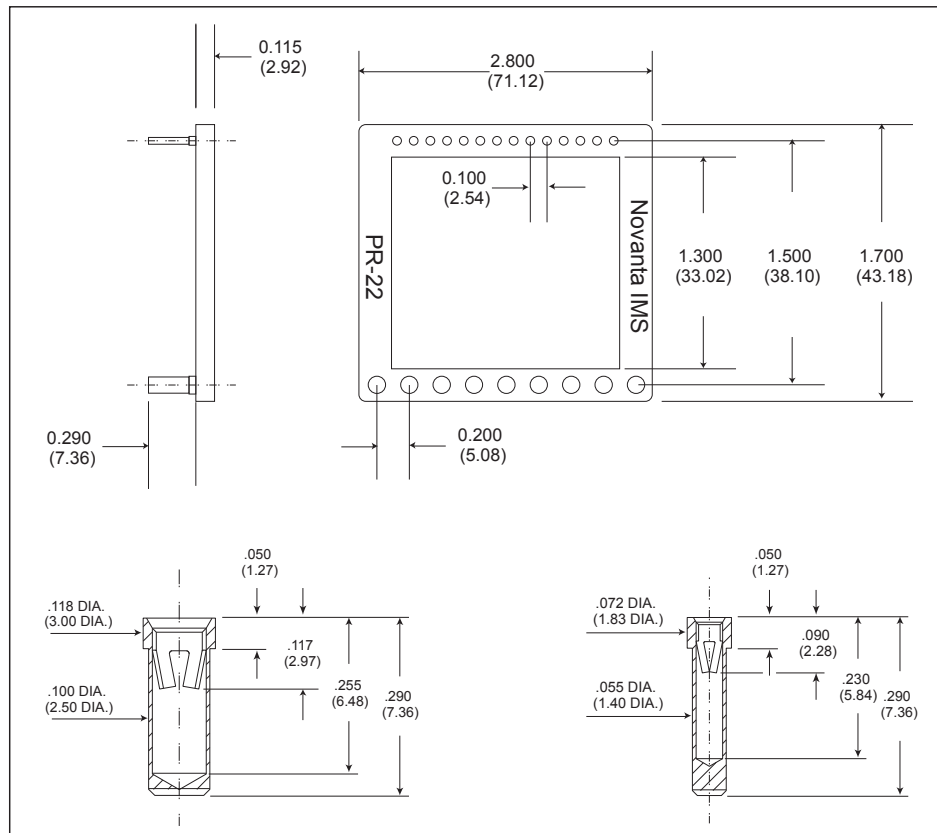

Figure 2.2: PR-22 Dimensions



WARNING! Do not apply power to the IM483H Plus/IM805H Plus without proper heat sinking or cooling! The included thermal pad (TI-22) **MUST** be used between the IM483H Plus/IM805H Plus and the heat sink! The maximum rear plate temperature of the IM483H Plus/IM805H Plus is +85°C!

Thermal Specifications

IM483H Plus/IM805H Plus Thermal Specifications	
Specification	Range
Ambient Temperature	0 to 50°C
Storage Temperature	-40 to +125°C
Maximum Plate Temperature	+85°C

Table 2.1: IM483H Plus/IM805H Plus Thermal Specifications



NOTE: Care should be taken when choosing a heat sink to ensure that there is good thermal flow, otherwise hot spots may occur in the IM483H Plus/IM805H Plus which will reduce the effectiveness of the thermal protection.



NOTE: An optional cooling fan assembly (Part # HFC-22) is available for the IM483H Plus/IM805H Plus.

Electrical Specifications

IM483H Plus DC Electrical Characteristics

Test Parameters: $T_A = 25^\circ\text{C}$, $+V = 48\text{V}$					
Specification	Test Condition / Notes	Min	Typ	Max	Units
Input Voltage		12	–	48*	V
Phase Output Current	RMS	–	–	3	A
	Peak	0.5	–	4.2	A
Quiescent Current (+5V, pin 14)	Inputs/Outputs Floating	–	140	225	mA
Active Power Dissipation	$I_{\text{OUT}} = 3\text{A RMS}$	–	7	9	W
Low Level Input Voltage	All Inputs	–	–	1.2	V
High Level Input Voltage	All Inputs Except RESET	–	–	2.0	V
	RESET	–	2.3	–	V
Input Pull-Up Resistance	RES SEL 0-3, ENABLE	–	20	–	k Ω
	STEP CLOCK DIRECTION	–	2.0	–	k Ω
	RESET	0.9	1.0	1.1	k Ω
	FAULT IN	–	4.7	–	k Ω
Low Level Output Current	FAULT, FULLSTEP, Inactive	–	–	–2	mA
High Level Output Current	FAULT, FULLSTEP, Active	–	–	2	mA
Low Level Output Voltage, V_{OL}	$I_{\text{OL}} = 1.4\text{ mA}$	–	–	0.5	V
High Level Output Voltage, V_{OH}	$I_{\text{OH}} = -1.7\text{ mA}$	2.3	–	–	V
Step Clock	Rate	–	–	2.5	MHz
	Width	200	–	–	nS
	Response	–	650	–	nS
Direction Setup/Hold		–	50/100	–	nS
MSEL Setup		–	4	–	mS
Full Step (zero cross)	Response	–	650	–	nS
Reset Pulse Width		1	–	–	μS
Enable	Response	–	4	–	mS
Variable PWM Frequency (step rate dependent)	min: reset to low speed max: high speed	20	–	60	kHz

* Includes Back EMF of Motor

Highlighted Specifications Represent Changes from the legacy IM483H.

Table 2.2: IM483H Plus DC Electrical Characteristics

IM805H Plus DC Electrical Characteristics

Test Parameters: $T_A = 25^\circ\text{C}$, $+V = 48\text{V}$					
Specification	Test Condition / Notes	Min	Typ	Max	Units
Input Voltage		12	–	75*	V
Phase Output Current	RMS	–	–	5	A
	Peak	1	–	7.1	A
Quiescent Current (+5V, pin 14)	Inputs/Outputs Floating	–	140	225	mA
Active Power Dissipation	$I_{\text{OUT}} = 3\text{A RMS}$	–	9	12	W
Low Level Input Voltage	All Inputs	–	–	1.2	V
High Level Input Voltage	All Inputs Except RESET	–	–	2.0	V
	RESET	–	2.3	–	V
Input Pull-Up Resistance	RES SEL 0-3, ENABLE	–	20	–	k Ω
	STEP CLOCK DIRECTION	–	2.0	2.2	k Ω
	RESET	0.9	1.0	1.1	k Ω
	FAULT IN	–	4.7	–	k Ω
Low Level Output Current	FAULT, FULLSTEP, Inactive	–	–	–2	mA
High Level Output Current	FAULT, FULLSTEP, Active	–	–	2	mA
Low Level Output Voltage, V_{OL}	$I_{\text{OL}} = 1.4\text{ mA}$	–	–	0.5	V
High Level Output Voltage, V_{OH}	$I_{\text{OH}} = -1.7\text{ mA}$	2.3	–	–	V
Step Clock	Rate	–	–	2.5	MHz
	Width	200	–	–	nS
	Response	–	650	–	nS
Direction Setup/Hold		–	0/50	–	nS
MSEL Setup		–	4	–	mS
Full Step (zero cross)	Response	–	650	–	nS
Reset Pulse Width		1	–	–	μS
Enable	Response	–	4	–	mS
Variable PWM Frequency (step rate dependent)	min: reset to low speed max: high speed	20	–	60	kHz

* Includes Back EMF of Motor

Highlighted Specifications Represent Changes from the legacy IM805H.

Table 2.3: IM805H Plus DC Electrical Characteristics

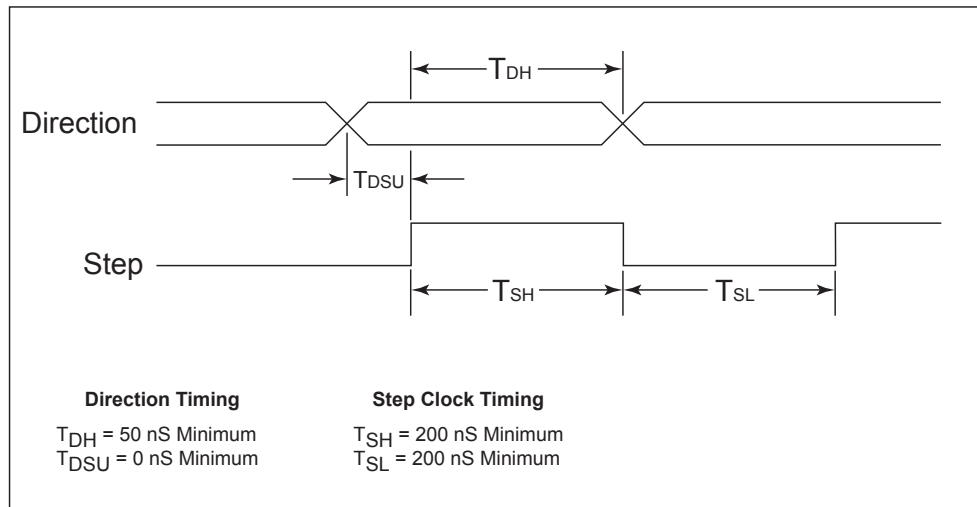

Figure 2.3: IM483H Plus/IM805H Plus Step and Direction Timing Diagram

Pin Assignment and Description

PIN #	PIN NAME	FUNCTION
Connector P1		
1	CURRENT REFERENCE	Phase current reference output. A resistor is connected between this 1 mA current source output and the Ground pin (pin 11) to generate the voltage used to set the peak phase current in the motor.
2	CURRENT ADJUSTMENT	Phase current adjustment input. A voltage applied to this input sets the peak phase current in the motor. Note: DC Power must be connected if using the internal current reference.
3	CURRENT REDUCTION ADJUSTMENT	Phase current reduction adjustment input. A resistor connected between this pin and Power Ground will proportionately reduce current in both windings 0.5 seconds after the last positive edge of the step clock input.
4	FAULT INPUT	A low signal on this input will generate a latched fault condition. The fault condition can only be cleared by cycling power or resetting the driver by toggling the Reset Input.
5-8	RESOLUTION SELECT 0-3	Microstep Resolution Select (MSEL) inputs. Used to select the number of microsteps per full step of the motor. See Microstep Selection Table 6.3.
9	STEP CLOCK INPUT	A positive going edge on this input advances the motor one increment. The size of the increment is dependent on the microstep select inputs.
10	DIRECTION INPUT	This input is used to change the direction of the motor. Physical direction also depends on the connection of the motor windings.
11	ENABLE INPUT	This input is used to enable/disable the output section of the driver. When high, the outputs are enabled. However, this input does not inhibit the step clock. Therefore when disabled the outputs will update by the number of clock pulses (if any) applied to the driver while it had been disabled.
12	ON FULL STEP OUTPUT	This totem-pole output indicates when the driver is positioned at a full step. This output can be used to count the number of full steps the motor has moved, regardless of the number of microsteps in between. This output is active high.
13	FAULT OUTPUT	This totem-pole output indicates a short circuit has occurred or a low signal was detected on the Fault input. This output is active high.
14	RESET INPUT	When low, this input will reset the driver (phase outputs will disable). When released, the driver will be at its initial state (phase A off, phase B on).

Table 2.4: IM483H Plus/IM805H Plus Connector P1 Configuration

PIN #	PIN NAME	DESCRIPTION
Connector P2		
1	PHASE /B	Phase /B of the stepping motor.
2	GND B	Motor Phase B Ground. This Ground should be connected to the "ground" lead of the external capacitor for Phase B.
3	PHASE B	Phase B of the stepping motor.
4	SUPPLY GROUND	Supply voltage ground (return).
5	+V	Supply voltage input: +12 to +48 (IM483H Plus), +12 to +75 (IM805H Plus).
6	+5V	+5VDC supply input. This supply is used to power the internal logic. The +5VDC supply should be referenced to pin 4 (supply ground). The 5 Volt supply must be capable of supplying 225 mA minimum.
7	PHASE A	Phase B of the stepping motor.
8	GND A	Motor Phase A Ground. This Ground should be connected to the "ground" lead of the external capacitor for Phase A.
9	PHASE /A	Phase /A of the stepping motor.

Table 2.5: IM483H Plus/IM805H Plus Connector P2 Configuration

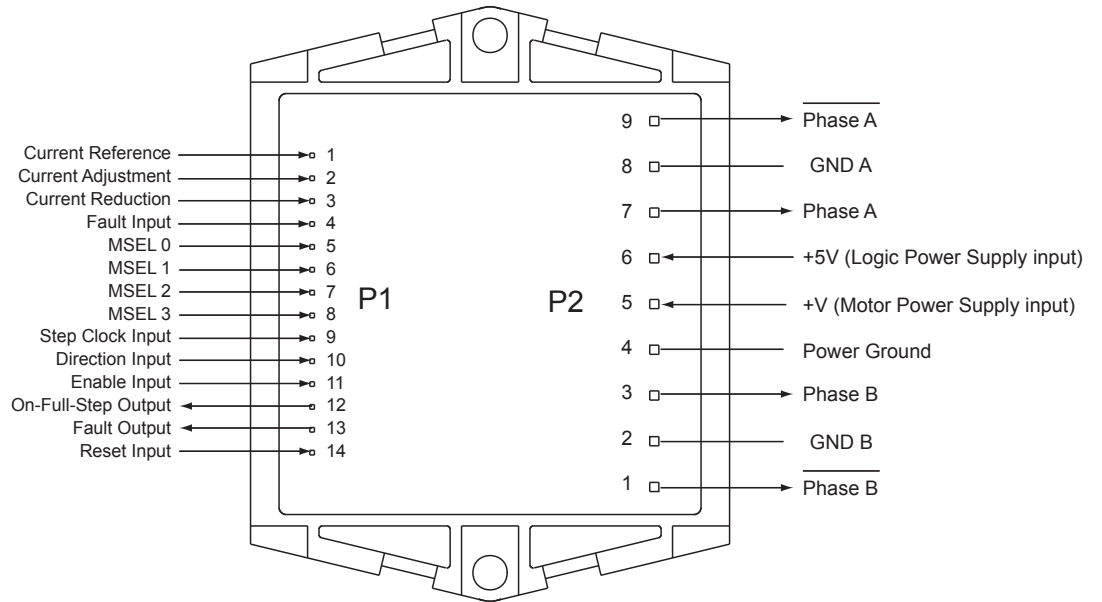

IMxH Plus Bottom View

Figure 2.4: IM483H Plus/IM805H Plus Connectors

N NOTE: If upgrading your system from an IM483H Plus to an IM805H Plus, or vice-versa, please note that the Phase A and Phase /A output pins (Pins 7 & 9) are reversed. This will cause the motor to turn in the opposite direction. To correct this condition swap the motor wires on Phase A.

Section 3

Mounting the IM483H Plus/IM805H Plus

Section Overview

This section covers mounting the IM483H Plus/IM805H Plus in your system. The following mounting options are covered:

- Mounting the IM483H Plus/IM805H Plus to a PCB.
- Mounting the IM483H Plus/IM805H Plus using the PR-22 Pin Receptacle.
- Recommended Mounting Hardware.
- Attaching/Removing the HFC-22 Heat Sink/Fan/Clip Assembly.

Mounting the IM483H Plus/IM805H Plus

The IM483H Plus and IM805H Plus hybrids are designed to be soldered into the user's PC board, however, they may also be mounted using the PR-22 pin receptacle carrier for ease of removal.

Direct Mounting the IM483H Plus/IM805H Plus to a PC Board

The IM483H Plus and IM805H Plus hybrids are designed to be soldered directly into a PC board. The following diagram contains the hole pattern and recommended pad sizes for direct mounting of the IM483H Plus/IM805H Plus.

Recommended Soldering Practices

Max. Soldering Temp 371°C (700°F)
Max. Soldering Time 10 sec.

Recommended Solder

Novanta IMS Recommends the use of a SAC305 (Sn96.5Ag3.0Cu0.5) lead free solder for RoHS compliant circuit board manufacture.

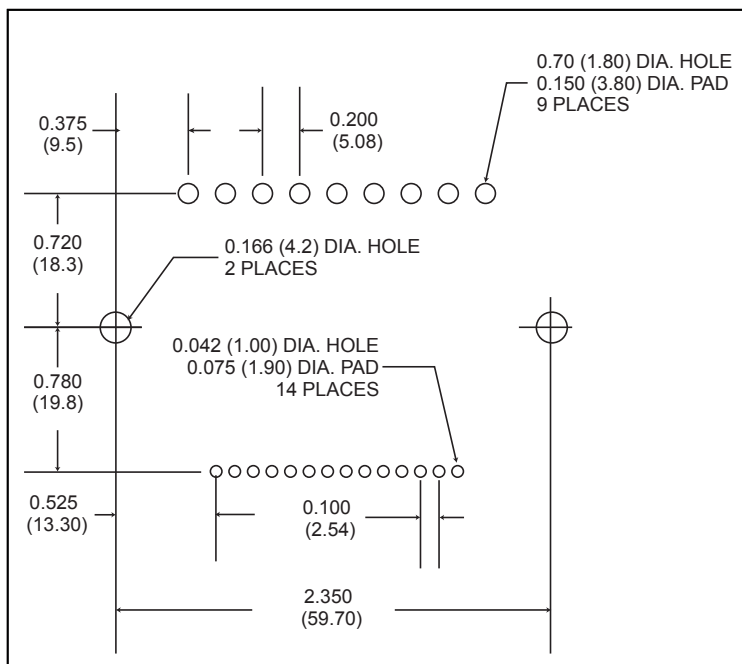

Figure 3.1: PCB Hole Pattern (Direct Mounting of the IM483H Plus/IM805H Plus to a PC Board)

Mounting the IM483H Plus/IM805H Plus Using the PR-22 Receptacle

The PR-22 pin receptacle carrier allows for easy placement of multi-fingered receptacle pins facilitating easy removal and placement of the IM483H Plus/IM805H Plus driver. The PR-22 is a disposable plastic frame containing 23 receptacles in a layout that matches the pin layout of the IM483H Plus/IM805H Plus hybrid.

This tool enables the user to insert the 23 receptacles into their PC board design in a single operation for wave or hand Figure 3.3 shows the PCB hole pattern and recommended pad size that should be used on the end-user PC board. The recommended mounting hardware components are illustrated in Figure 3.4.

To lift the disposable carrier after soldering, gently pry the carrier from the PCB with a flat head screwdriver or, to avoid chancing PC board damage, use the optional pry bar (PB-22).

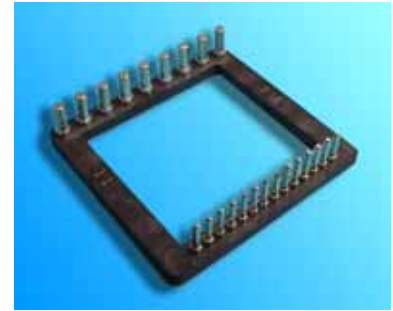

Figure 3.2: PR-22 Pin Receptacle Carrier

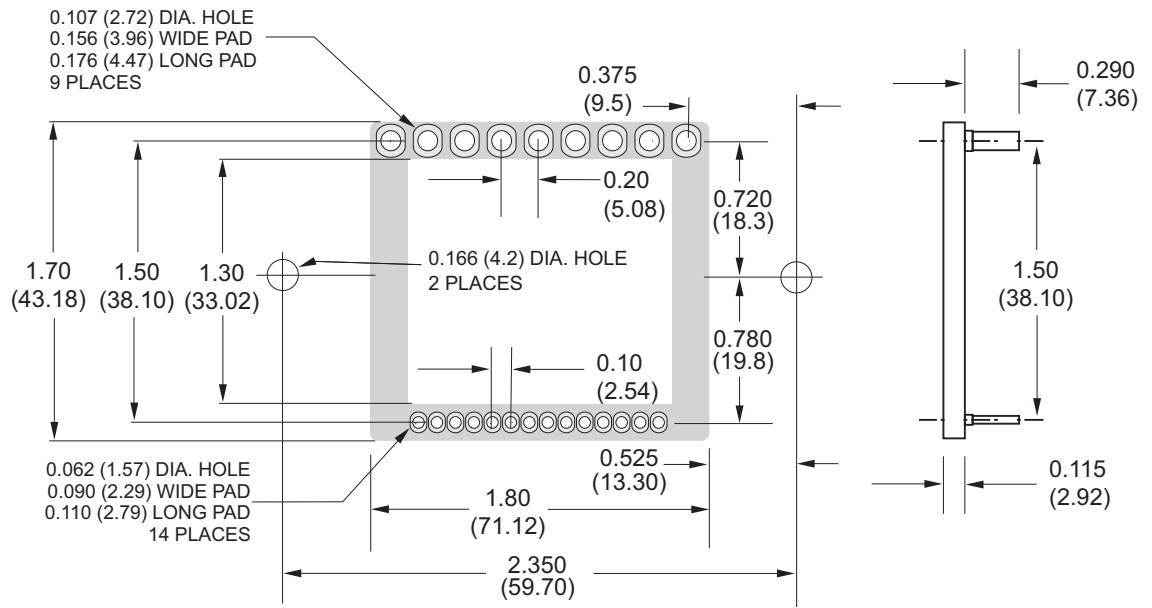

Figure 3.3: PCB Hole Pattern (for Mounting of the PR-22 Pin Receptacle Carrier)



WARNING! The torque specification for the mounting screws is 5.0 to 7.0 lb-in (0.60 to 0.80 N-m). Do not over tighten screws!

Recommended Mounting Hardware

Figure 3.4 illustrates the recommended mounting hardware. This hardware and associated torque specification will be the same whether the PR-22 pin receptacle carrier is used or the driver is directly mounted to a PC Board.



WARNING! The IM483H Plus/IM805H Plus Drivers are not hermetically sealed. DO NOT wash the PCB with the Driver soldered in place. Always wash the PCB prior to mounting the Driver. NEVER use compressed air.

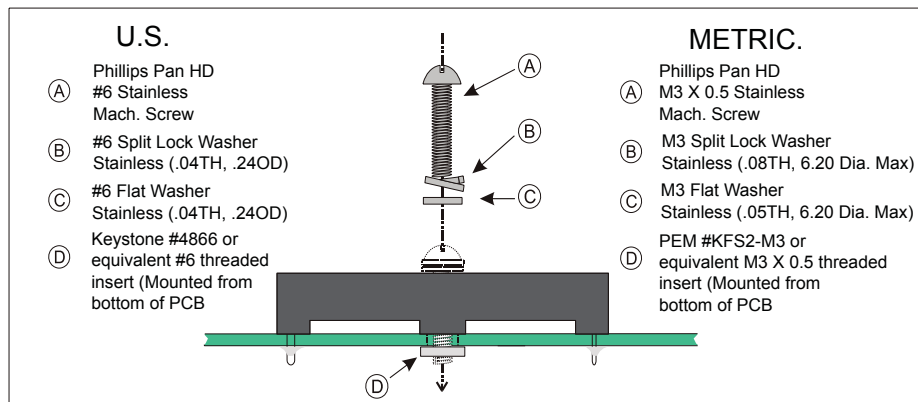

Figure 3.4: PCB Mounting Hardware (Direct Mounting or Socketed)

Attaching the HFC-22 Heat Sink/Fan/Clip Assembly

Figure 3.5 illustrates the HFC-22 mounted to the IM483H Plus/IM805H Plus. To attach the HFC-22 complete the following:

- 1) Placing the heat sink on the driver, align so that the dot on the heat sink is on the same side as the dot on the driver, with the TI-22 thermal pad sandwiched between them.
- 2) Insert two of the arms from the fan/clip assembly into the corresponding slots in the driver, aligning the curved fingers on the clip between the posts of the heat sink. Insert the other two locking tabs into the opposite slots and snap into place. The locking tabs on all four arms should be completely through the slots on the driver.

Recommended Connector

The HFC-22 fan connector plugs into the following pin header:

- Molex Part Number: 22-23-2021
- Digikey Part Number: WM4200-ND
- Samtec Part Number: TSW-101-07-T-D

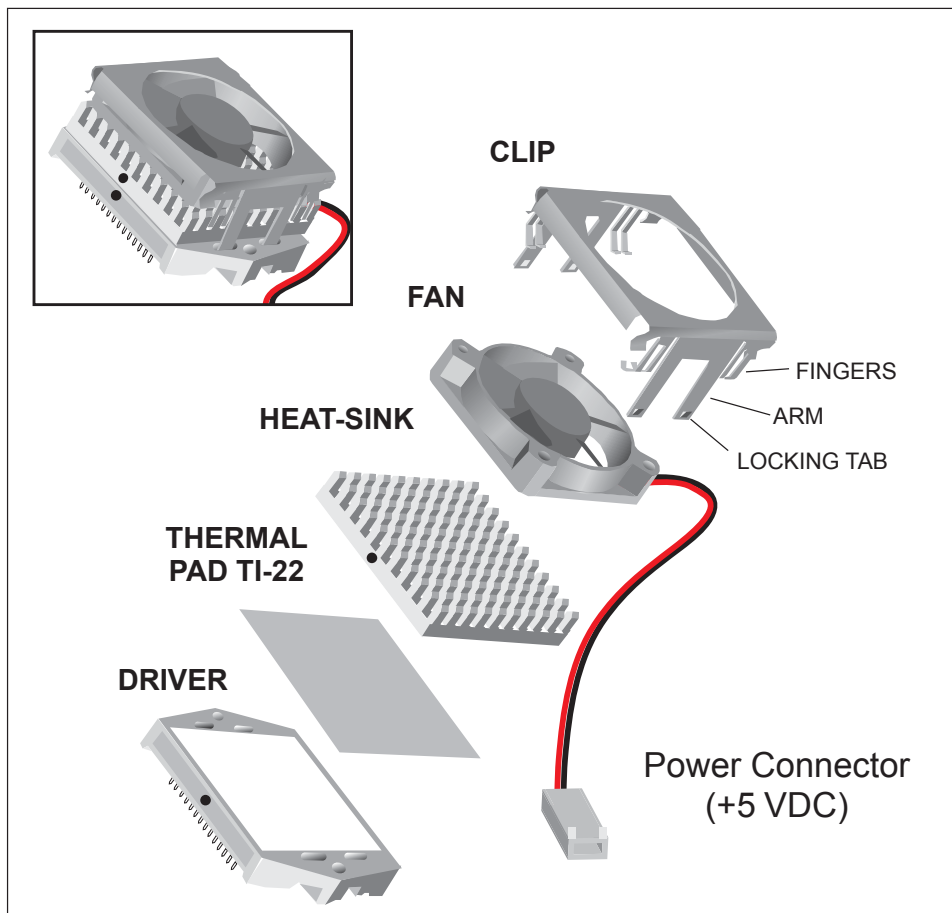



Figure 3.5: HFC-22 Heat Sink/Fan/Clip Assembly

Removing the HFC-22 Heat Sink/Fan/Clip Assembly

To remove the HFC-22 from the driver:

- 1) Squeeze the two arms on one side of the assembly until the locking tabs are free in the slot on the drive.
- 2) Gently lift the freed side away from the drive. The HFC-22 will separate from the drive. (The fan will be locked inside the clip.)

 **WARNING!** The heat sink mounting surface must be a smooth, flat surface with no burrs, protrusions, cuttings or other foreign objects.

 **WARNING!** If the curved fingers do not align between the posts on the heat sink do not try and force them. Verify that the heat sink is sitting square on the driver and that the dot on the heat sink is on the same side as the dot on the driver!

 **WARNING!** Be certain to remove the clear protective sheet from the TI-22 Thermal Pad before installation.

Section 4

Power Supply Requirements

Section Overview

This section covers the power supply requirements of the IM483H Plus/IM805H Plus. Precise wiring and connection details are to be found in Section 6: Interfacing to the IM483H Plus/IM805H Plus. The following is covered by this section:

- Selecting a Power Supply.
- Recommended Wiring.
- AC Line Filtering.

Selecting a Power Supply

Selecting a Motor Supply (+V)

Proper selection of a power supply to be used in a motion system is as important as selecting the drive itself. When choosing a power supply for a stepping motor driver, there are several performance issues that must be addressed. An undersized power supply can lead to poor performance and possibly even damage to your drive.

The Power Supply - Motor Relationship

Motor windings can basically be viewed as inductors. Winding resistance and inductance result in an L/R time constant that resists the change in current. To effectively manipulate the rate of charge, the voltage applied is increased. When traveling at high speeds, there is less time between steps to reach current. The point where the rate of commutation does not allow the driver to reach full current is referred to as voltage mode. Ideally you want to be in current mode, which is when the drive is achieving the desired current between steps. Simply stated, a higher voltage will decrease the time it takes to charge the coil and, therefore, will allow for higher torque at higher speeds.

Another characteristic of all motors is back EMF. Back EMF is a source of current that can push the output of a power supply beyond the maximum operating voltage of the driver. As a result, damage to the stepper driver could occur over a period of time.

The Power Supply - Driver Relationship

The IM483H Plus/IM805H Plus is very current efficient as far as the power supply is concerned. Once the motor has charged one or both windings of the motor, all the power supply has to do is replace losses in the system. The charged winding acts as an energy storage in that the current will recirculate within the bridge and in and out of each phase reservoir. This results in a less than expected current draw on the supply.

Stepping motor drivers are designed with the intent that a user's power supply output will ramp up to greater than or equal to the minimum operating voltage. The initial current surge is substantial and could damage the driver if the supply is undersized. The output of the power supply could fall below the operating range of the driver upon a current surge, if it is undersized. This could cause the power supply to start oscillating in and out of the voltage range of the driver and result in damage to either the supply, the driver, or both. There are two types of supplies commonly used, regulated and unregulated, both of which can be switching or linear. Each have advantages and disadvantages.

Regulated vs. Unregulated

An unregulated linear supply is less expensive and more resilient to current surges, however, the voltage decreases with increasing current draw. This can cause problems if the voltage drops below the working range of the drive. Also of concern are the fluctuations in line voltage. This can cause the unregulated linear supply to be above or below the anticipated or acceptable voltage.

A regulated supply maintains a stable output voltage, which is good for high speed performance. These supplies are also not effected by line fluctuations, however, they are more expensive. Depending on the current regulation, a regulated supply may crowbar or current clamp and lead to an oscillation that, as previously stated, can cause damage to the driver and/or supply. Back EMF can cause problems for regulated supplies as well. The current regeneration may be too large for the regulated supply to absorb. This could lead to an over voltage condition which could damage the output circuitry of the IM483H Plus/IM805H Plus.

Non Novanta IMS switching power supplies and regulated linear supplies with overcurrent protection are not recommended because of their inability to handle the surge currents inherent in stepping motor systems.

Motor Power Specification		
Specification	IM483H Plus	IM805H Plus
Recommended Supply Type	Unregulated DC	
Ripple Voltage	± 10%	
Output Voltage	+12 to +48 VDC	+12 to +75 VDC
Output Current*	3A Peak	4A Peak

* The output current is dependant on the power supply voltage, the motor selection and the load.

Table 4.1: Motor Power Supply Specifications

Recommended Novanta IMS Power Supplies

Novanta IMS has designed a series of low cost miniature unregulated Switching and Linear Supplies that can handle extreme varying load conditions. This makes them ideal for stepper motor drives and DC servo motors. Each of these is available in either 120 or 240 VAC configuration. See the Novanta IMS Catalog or website (www.novantaims.com) for more information. Listed below are the power supplies recommended for use with the IM483H Plus/IM805H Plus.

IP404/ISP200-4 (IM483H Plus)

	Range
120 VAC Version	102-132 VAC
240 VAC Version	204-264 VAC
IP404 Unregulated Linear Supply	
No Load Output Voltage*	43 VDC @ 0 Amps
Continuous Output Rating*	32 VDC @ 2 Amps
Peak Output Rating*	26 VDC @ 4 Amps
ISP200-4 Unregulated Switching Supply	
No Load Output Voltage*	41 VDC @ 0 Amps
Continuous Output Rating*	38 VDC @ 1.5 Amps
Peak Output Rating*	35 VDC @ 3 Amps

IP804/ISP200-7 (IM805H Plus)

	Range
120 VAC Version	102-132 VAC
240 VAC Version	204-264 VAC
IP804 Unregulated Linear Supply	
No Load Output Voltage*	76 VDC @ 0 Amps
Continuous Output Rating*	65 VDC @ 2 Amps
Peak Output Rating*	58 VDC @ 4 Amps
ISP200-7 Unregulated Switching Supply	
No Load Output Voltage*	70 VDC @ 0 Amps
Continuous Output Rating*	62 VDC @ 1 Amps
Peak Output Rating*	59 VDC @ 2 Amps

* All measurements were taken at 25°C, 120 VAC, 60 Hz.

Selecting a +5 VDC Supply

+5 VDC Power Specification		
Specification	IM483H Plus	IM805H Plus
Recommended Supply Type	Unregulated DC or Switch Mode DC	
Ripple Voltage	± 10%	
Output Voltage	+5 VDC	+5 VDC
Output Current	225mA	225mA

Table 4.2: +5VDC Power Supply Specifications



WARNING!
Verify that the power supply wiring is correct prior to power application. If +V and GND are connected in reverse order, catastrophic damage to the IM483H Plus/IM805H Plus may occur! Ensure that the power supply output voltage does not exceed +48/75VDC, the maximum input voltage of the IM483H Plus/IM805H Plus!



WARNING!
Hazardous voltage levels may be present if using an open

frame power supply to power the IM483H Plus/IM805H Plus!

Recommended Wiring

Rules of Wiring and Shielding

Noise is always present in a system that involves both high power and small signal circuitry. Regardless of the power configuration used for your system, there are some wiring and shielding rules that should be followed to keep the noise to signal ratio as small as possible.

Rules of Wiring

- Power supply and motor wiring should be shielded twisted pairs run separately from signal carrying wires.
- A minimum of 1 twist per inch is recommended.
- Motor wiring should be shielded twisted pairs using 20-gauge wire or, for distance greater than 5 feet, 18 gauge or better.
- Power ground return should be as short as possible to established ground.
- Power supply wiring should be shielded twisted pairs. Use 18 gauge wire if load is less than 4 amps, or 16 gauge for more than 4 amps.
- Do not “Daisy-Chain” power wiring to system components.

Rules of Shielding

- The shield must be tied to zero-signal reference potential. In order for shielding to be effective, it is necessary for the signal to be earthed or grounded.
- Do not assume that earth ground is true earth ground. Depending on the distance to the main power cabinet, it may be necessary to sink a ground rod at a critical location.
- The shield must be connected so that shield currents drain to signal-earth connections.
- The number of separate shields required in a system is equal to the number of independent signals being processed plus one for each power entrance.
- The shield should be tied to a single point to prevent ground loops.
- A second shield can be used over the primary shield, however, the second shield is tied to ground at both ends.

Recommended Power Supply Cables

Power supply cables must not run parallel to logic level wiring as noise will be coupled onto the logic signals from the power supply cables. If more than one driver is to be connected to the same power supply, run separate power and ground leads to each driver from the power supply. The following Belden cables (or equivalent) are recommended for use with the IM483H Plus/IM805H Plus.

Twisted pair jacketed

<4Amps DC	Belden Part# 9740 or equivalent 18 Gauge
>4Amps DC	Belden Part# 8471 or equivalent 16 Gauge

AC Line Filtering

Since the output voltage of an unregulated power supply will vary with the AC input applied, it is recommended that an AC line filter be used to prevent damage to the IM483H Plus/IM805H Plus due to a lightning strike or power surge.

Section 5

Motor Requirements

Section Overview

This section covers the motor configurations for the IM483H Plus/IM805H Plus.

- Selecting a Motor.
- Motor Wiring.
- Connecting the Motor.

Selecting a Motor

When selecting a stepper motor for your application, there are several factors that need to be taken into consideration.

- How will the motor be coupled to the load?
- How much torque is required to move the load?
- How fast does the load need to move or accelerate?
- What degree of accuracy is required when positioning the load?

While determining the answers to these and other questions is beyond the scope of this document, they are details that you must know in order to select a motor that is appropriate for your application. These details will effect everything from the power supply voltage to the type and wiring configuration of your stepper motor. The current and microstepping settings of your IM483H Plus/IM805H Plus drive will also be effected.

Types and Construction of Stepping Motors

The stepping motor, while classed as a DC motor, is actually an AC motor that is operated by trains of pulses. Although it is called a “stepping motor”, it is in reality a polyphase synchronous motor. This means it has multiple phases wound in the stator and the rotor is dragged along in synchronism with the rotating magnetic field. The IM483H Plus/IM805H Plus is designed to work with the following types of stepping motors:

- 1) Permanent Magnet (PM)
- 2) Hybrid Stepping Motors

Hybrid stepping motors combine the features of the PM stepping motors with the features of another type of stepping motor called a variable reluctance motor (VR), which is a low torque and load capacity motor that is typically used in instrumentation. The IM483H Plus/IM805H Plus cannot be used with VR motors as they have no permanent magnet.

On hybrid motors, the phases are wound on toothed segments of the stator assembly. The rotor consists of a permanent magnet with a toothed outer surface which allows precision motion accurate to within ± 3 percent. Hybrid stepping motors are available with step angles varying from 0.45° to 15° with 1.8° being the most commonly used. Torque capacity in hybrid steppers ranges from 5 - 8000 ounce-inches. Because of their smaller step angles, hybrid motors have a higher degree of suitability in applications where precise load positioning and smooth motion is required.

Sizing a Motor for Your System

The IM483H Plus/IM805H Plus is a bipolar driver which works equally well with both bipolar and unipolar motors (i.e. 8 and 4 lead motors, and 6 lead center tapped motors).

To maintain a given set motor current, the IM483H Plus/IM805H Plus chops the voltage using a constant 20kHz chopping frequency and a varying duty cycle. Duty cycles that exceed 50% can cause unstable chopping. This characteristic is directly related to the motor's winding inductance. In order to avoid this situation, it is necessary to choose a motor with a low winding inductance. The lower the winding inductance, the higher the step rate possible.

Winding Inductance

Since the IM483H Plus/IM805H Plus is a constant current source, it is not necessary to use a motor that is rated at the same voltage as the supply voltage. What is important is that the IM483H Plus/IM805H Plus is set to the motor's rated current. See Section 7: Interfacing to the IM483H Plus/IM805H Plus for more details.

As was discussed in the previous section, Power Supply Requirements, the higher the voltage used the faster the current can flow through the motor windings. This in turn means a higher step rate, or motor speed. Care should be taken not to exceed the maximum voltage of the driver. Therefore, in choosing a motor for a system design, the best performance for a specified torque is a motor with the lowest possible winding inductance used in conjunction with

highest possible driver voltage.

The winding inductance will determine the motor type and wiring configuration best suited for your system. While the equation used to size a motor for your system is quite simple, several factors fall into play at this point.

The winding inductance of a motor is rated in milliHenrys (mH) per Phase. The amount of inductance will depend on the wiring configuration of the motor.

The per phase winding inductance specified may be different than the per phase inductance seen by your IM483H Plus/IM805H Plus driver depending on the wiring configuration used. Your calculations must allow for the actual inductance that the driver will see based upon the motor's wiring configuration used.

Figure 5.1A shows a stepper motor in a series configuration. In this configuration, the per phase inductance will

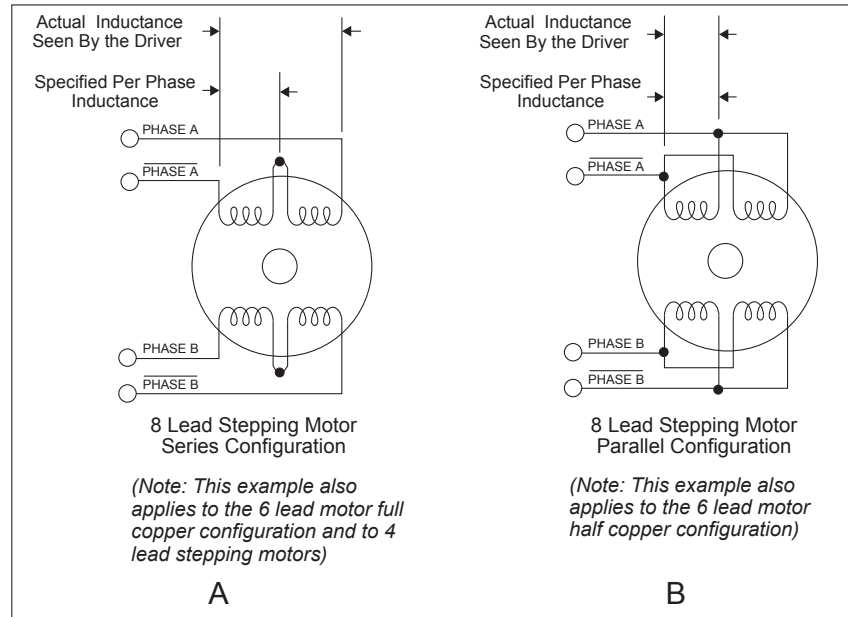

Figure 5.1 A & B: Per Phase Winding Inductance

be 4 times that specified. For example: a stepping motor has a specified per phase inductance of 1.47mH. In this configuration the driver will see 5.88 mH per phase.

Figure 5.1B shows an 8 lead motor wired in parallel. Using this configuration the per phase inductance seen by the driver will be as specified.

Using the following equation we will show an example of sizing a motor for a IM483H Plus/IM805H Plus used with an unregulated power supply with a minimum voltage (+V) of 18 VDC:

$$.2 \times 18 = 3.6 \text{ mH}$$

The maximum per phase winding inductance we can use is 3.6 mH.

N NOTE: In calculating the maximum phase inductance, the minimum supply output voltage should be used when using an unregulated supply.



$$\text{Maximum Motor Inductance (mH per Phase)} = 0.2 \times \text{Minimum Supply Voltage}$$

Recommended Novanta IMS Motors

Novanta IMS stocks the following 4 lead, 1.8° enhanced torque hybrid stepping motors that are recommended for the IM483H Plus and IM805H Plus.

These motors use a unique relationship between the rotor and stator to generate more torque per frame size while ensuring more precise positioning and increased accuracy.

The special design allows the motors to provide higher torque than standard stepping motors while maintaining a steadier torque and reducing torque drop-off.

Each frame size is available in 3 stack sizes, single or double shaft (with the exception of the size 23, 2.4A) and are available with or without encoders.

These CE rated motors are ideal for applications where higher torque is required. For more detailed information on these motors, please see the Novanta IMS Full Line catalog or the Novanta IMS web site at www.novantaims.com.

17 Frame Enhanced (1.5A) - IM483H Plus

Single Shaft	Double Shaft
M-1713-1.5S	M-1713-1.5D
M-1715-1.5S	M-1715-1.5D
M-1719-1.5S	M-1719-1.5D

23 Frame Enhanced (2.4A - Not Available with Double Shaft) - IM483H Plus

Single Shaft	Double Shaft
M-2218-2.4S	N/A
M-2222-2.4S	N/A
M-2231-2.4S	N/A

23 Frame Enhanced (3.0A) - IM483H Plus/IM805H Plus

Single Shaft	Double Shaft
M-2218-3.0S	M-2218-3.0D
M-2222-3.0S	M-2222-3.0D
M-2231-3.0S	M-2231-3.0D

34 Frame Enhanced (6.3A) - IM805H Plus

Single Shaft	Double Shaft
M-3424-6.3S	M-3424-6.3-D
M-3431-6.3S	M-3431-6.3D
M-3447-6.3S	M-3447-6.3D

Novanta IMS also offers 17, 23 and 34 Frame hybrid linear actuators for use with the IM483H Plus and IM805H Plus. Please see the Novanta IMS Full Line catalog or the Novanta IMS web site at www.novantaims.com

Novanta IMS Inside Out Stepper Motors

The new inside out stepper (IOS) motor was designed by Novanta IMS to bring versatility to stepper motors using a unique multi-functional, hollow core design.

This versatile new motor can be converted to a ball screw linear actuator by mounting a miniature ball screw to the front shaft face. Ball screw linear actuators offer long life, high efficiency, and can be field retrofitted. There is no need to throw the motor away due to wear of the nut or screw.

The IOS motors offer the following features:

- The shaft face diameter offers a wide choice of threaded hole patterns for coupling.
- The IOS motor can be direct coupled in applications within the torque range of the motor, eliminating couplings and increasing system efficiency.
- The IOS motor can replace gearboxes in applications where gearboxes are used for inertia dampening between the motor and the load. The induced backlash from the gearbox is eliminated providing improved bi-directional position accuracy.
- Electrical or pneumatic lines can be directed through the center of the motor enabling the motors to be stacked end-to-end or applied in robotic end effector applications. The through hole is stationary, preventing cables from being chaffed by a moving hollow shaft.
- Light beams can be directed through the motor for refraction by a mirror or filter wheel mounted on the shaft mounting face.
- The IOS motor is adaptable to valves enabling the valve stem to protrude above the motor frame. The stem can be retrofitted with a dial indicator showing valve position.
- The motor is compatible with Novanta IMS bipolar drivers, keeping the system cost low.
- The IOS motor can operate up to 3000 rpm's.

The IOS motor is available in the following frames:

Frame Size

Novanta IMS PN



WARNING! Do not connect or disconnect motor or power leads with power applied!

17 Frame	M3-1713-IOS
23 Frame	M3-2220-IOS
34 Frame	M3-3424-IOS

Motor Wiring

As with the power supply wiring, motor wiring should be run separately from logic wiring to minimize noise coupled onto the logic signals. Motor cabling exceeding 1' in length should be shielded twisted pairs to reduce the transmission of EMI (Electromagnetic Interference) which can lead to rough motor operation and poor system performance overall. For more information on wiring and shielding, please refer to: Rules of Wiring and Shielding in Section 4 of this manual.

Below are listed the recommended motor cables:

Dual Twisted Pair Shielded (Separate Shields)

< 5 feet	Belden Part# 9402 or equivalent 20 Gauge
> 5 feet	Belden Part# 9368 or equivalent 18 Gauge

When using a bipolar motor, the motor must be within 100 feet of the drive.

Connecting the Motor

The motor leads are connected to the following connector pins:

IM483H Plus

Phase	Connector: Pin
Phase B	P2: 3
<u>Phase B</u>	P2: 1
<u>Phase A</u>	P2: 9
Phase A	P2: 7

IM805H Plus

Phase	Connector: Pin
Phase B	P2: 3
<u>Phase B</u>	P2: 1
Phase A	P2: 9
<u>Phase A</u>	P2: 7

8 Lead Motors

8 lead motors offer a high degree of flexibility to the system designer in that they may be connected in series or parallel, thus satisfying a wide range of applications.

Series Connection

A series motor configuration would typically be used in applications where a higher torque at low speeds is needed. Because this configuration has the most inductance, the performance will start to degrade at higher speeds. Use the per phase (or unipolar) current rating as the peak output current, or multiply the bipolar current rating by 1.4 to determine the peak output current.

Parallel Connection

An 8 lead motor in a parallel configuration offers a more stable, but lower torque at lower speeds. But because of the lower inductance, there will be higher torque at higher speeds. Multiply the per phase (or unipolar) cur-

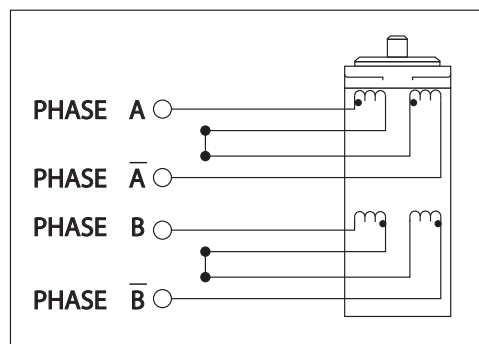

Figure 5.2: 8 Lead Series Motor Connections

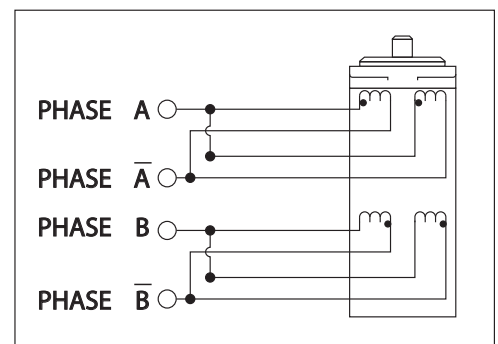

Figure 5.3: 8 Lead Parallel Motor Connections



NOTE: The physical direction of the motor with respect to the direction input will

depend upon the connection of the motor windings. To switch the direction of the motor with respect to the direction input, switch the wires on either Phase A or Phase B outputs.



NOTE: If upgrading your system from an IM483H Plus to an IM805H Plus, or vice-versa, please

note that the Phase A and Phase /A output pins (Pins 7 & 9) are reversed. This will cause the motor to turn in the opposite direction. To correct this condition swap the motor wires on Phase A.

rent rating by 1.96, or the bipolar current rating by 1.4, to determine the peak output current.

6 Lead Motors

Like 8 lead stepping motors, 6 lead motors have two configurations available for high speed or high torque operation. The higher speed configuration, or half coil, is so described because it uses one half of the motor's inductor windings. The higher torque configuration, or full coil, uses the full windings of the phases.

Half Coil Configuration

As previously stated, the half coil configuration uses 50% of the motor phase windings. This gives lower inductance, hence, lower torque output. Like the parallel connection of 8 lead motor, the torque output will be more stable at higher speeds. This configuration is also referred to as half copper. In setting the driver output current multiply the specified per phase (or unipolar) current rating by 1.4 to determine the peak output current.

Full Coil Configuration

The full coil configuration on a six lead motor should be used in applications where higher torque at lower speeds is desired. This configuration is also referred to as full copper. Use the per phase (or unipolar) current rating as the peak output current.

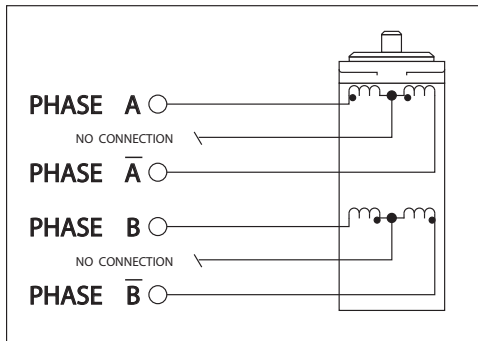

Figure 5.4: 6 Lead Half Coil (Higher Speed) Motor Connections

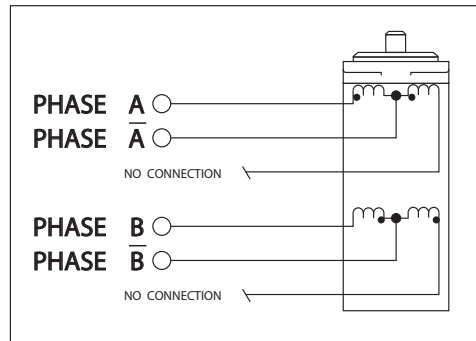

Figure 5.5: 6 Lead Full Coil (Higher Torque) Motor

4 Lead Motors

4 lead motors are the least flexible but easiest to wire. Speed and torque will depend on winding inductance. In setting the driver output current, multiply the specified phase current by 1.4 to determine the peak output current.

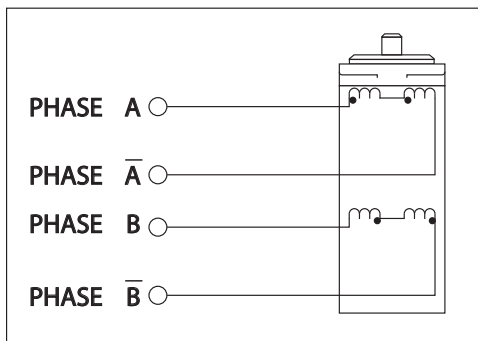

Figure 5.6: 4 Lead Motor Connections

Section 6

Interfacing to the IM483H Plus/IM805H Plus

Section Overview

The IM483H Plus/IM805H Plus was designed to be incorporated directly in the user's printed circuit board. In order to operate, the IM483H Plus/IM805H Plus must have the following connections:

- Motor Power (+V).
- +5VDC Input.
- MSEL Inputs.
- Current Adjust (Reduction is optional).
- Logic Interface.
- Minimum Connections.

Layout and Interface Guidelines

Logic level signals should not run parallel to motor phase signals. The motor phase signals will couple noise onto the logic level signals. This will cause rough motor motion and unreliable system operation. Motor phase signals should be run as pairs and should be separated from other signals by ground traces where possible.

When leaving the board, motor cables should not run parallel with other wires. Phases should be wired using twisted pairs. If motor cabling in excess of one foot is required, motor cabling should be shielded twisted pairs to reduce the transmission of EMI. The shield must be tied to AC ground at driver end only (or the supply ground if AC ground is not available). The motor end must be left floating.

If more than one driver is connected to the power supply, separate power and ground connections from each driver to the power supply should be used.

The power supply cables need to be a twisted pair if power is connected from a source external to the board. If multiple drivers are used with an external power source, and it is not possible to run separate power and ground connections to each driver, a low impedance electrolytic capacitor equivalent to two times the total capacitance of all driver capacitors and of equal voltage must be placed at the power input of the board.

Motor Power

Pins 5 (+V), and 2 & 8 (GND) on connector P2 are used to connect motor DC power to the IM483H Plus/IM805H Plus. Two local capacitors are needed. These must be located as close to the IM483H Plus/IM805H Plus's motor power input pins as possible to ensure stable operation.

The first two capacitors, one for each motor phase, are low impedance aluminum electrolytic capacitors. The continuous operating voltage of the capacitor should exceed the maximum

supply voltage as well as any additional voltage caused by the motor's back EMF.

The value of the capacitors should be approximately 150µF for every amp of peak per phase output current.

For power supply specifications and recommendations, see Section 5: Power Supply Requirements.

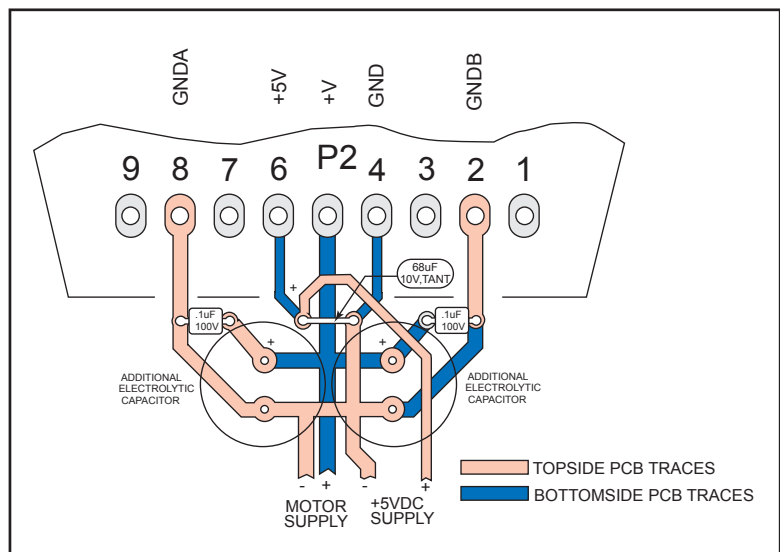

Figure 6.1: Power Interface



CALCULATING THE VALUE OF THE INPUT CAPACITORS

EXAMPLE: 3.2A (Peak Output Current @ 45VDC) X 150µF = 480µF 63V

+5 VDC Input

The IM483H Plus/IM805H Plus requires an external regulated +5VDC, $\pm 5\%$ power supply. The supply is connected between P2:6 (+5VDC Supply) and P2:4 (Power Ground). A 68 microfarad 10V tantalum capacitor must be placed as close to the IM483H Plus/IM805H Plus as possible between the +5VDC input pin (P2:6) and ground. (See Figure 6.1 on the previous page for PCB layout example.)

The +5VDC supply ground and the motor supply ground should not be connected together at the power supplies. The common ground connection between the motor power supply and the +5VDC supply should be made at the ground pin of the additional electrolytic capacitor used for the motor supply. (See Figure 6.1 on the previous page for PCB layout example.)

Interfacing the Current Adjust Input

For any given motor, the output current used for microstepping is determined differently from that of a half/full step driver.

In the IM483H Plus/IM805H Plus, a sine/cosine output function is used in rotating the motor. Therefore, when microstepping, the specified phase current of the motor is considered an RMS value.

Determining the Output Current

Stepper motors can be configured as 4, 6 or 8 leads. Each configuration requires different currents. Shown below are the different lead configurations and the procedures to determine the peak per phase output current setting that would be used with different motor/lead configurations.

4 Lead Motors

Multiply the specified phase current by 1.4 to determine the peak output current.



EXAMPLE: A 4 lead motor has a specified phase current of 2.0A

$$2.0A \times 1.4 = 2.8 \text{ Amps Peak}$$

6 Lead Motors

- 1) When configuring a 6 lead motor in a half coil configuration (i.e. connected from one end of the coil to the center tap (high speed configuration)) multiply the specified per phase (or unipolar) current rating by 1.4 to determine the peak output current.



EXAMPLE: A 6 lead motor in half coil configuration has a specified phase current of 3.0A

$$3.0A \times 1.4 = 4.2 \text{ Amps Peak}$$

- 2) When configuring the motor so the full coil is used (i.e. connected from end-to-end with the center tap floating (higher torque configuration)) use the per phase (or unipolar) current rating as the peak output current.

8 Lead Motors

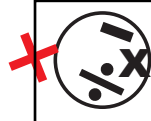

EXAMPLE: A 6 lead motor in full coil configuration with a specified phase current of 3.0A

$$3.0A \text{ per phase} = 3.0 \text{ Amps Peak}$$

SERIES CONNECTION:

- 1) When configuring the motor windings in series, use the per phase (or unipolar) current rating as the peak output current, or multiply the bipolar current rating by 1.4 to determine the peak output current.

PARALLEL CONNECTION:

- 2) When configuring the motor windings in parallel, multiply the per phase (or unipolar) current rating by 2.0 or the bipolar current rating by 1.4 to determine the peak output current.

Setting the Output Current



EXAMPLE: An 8 lead motor in series configuration with a specified unipolar current of 3.0A

3.0A per phase = 3.0 Amps Peak

An 8 lead motor in series configuration with a specified bipolar current of 2.8A

2.8 x 1.4 = 3.92 Amps Peak

The output current can be set on the IM483H Plus/IM805H Plus one of two ways:

- 1) By connecting the current reference output (P1:1) to the current adjust input (P1:2) and placing a resistor between this connection and ground (P2:4). This uses the internal 1mA current source



EXAMPLE: An 8 lead motor in parallel configuration with a specified unipolar current of 2.0A.

2.0A per phase X 2.0 = 4.0 Amps Peak

An 8 lead motor in parallel configuration with a specified bipolar current of 2.8A.

2.8 x 1.4 = 3.92 Amps Peak

provided at the current reference pin P1:1 (see figure 7.2).

- 2) By applying an external reference voltage to P1:2 (see figure 7.3).

Tables 6.1 and 6.2 show both the current adjust resistor values and the reference voltage required for peak per phase output current settings for the IM483H Plus and IM805H Plus.

The current adjustment resistor external reference voltage used to set the per phase output current of the IM483H Plus/IM805H Plus sets the peak per phase output of the sine/cosine waves not the RMS value. Therefore, the peak per phase output current must be used to determine the value to which the IM483H Plus/IM805H Plus will be set.

WARNING!
A current adjustment resistor or reference voltage is always necessary to keep the Driver and/or Motor in a safe operating range.

DO NOT operate the IM483H Plus/IM805H Plus Drivers without a current control in place.

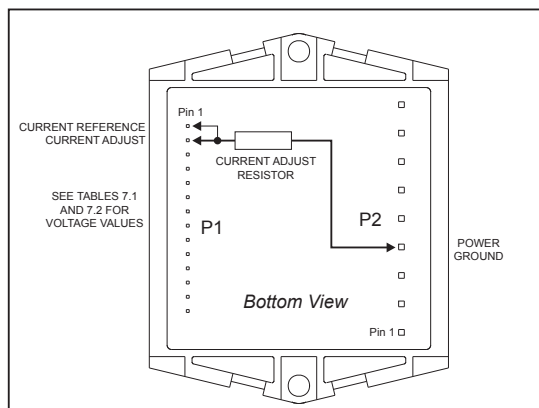

Figure 6.2: Current Adjust Resistor Connection

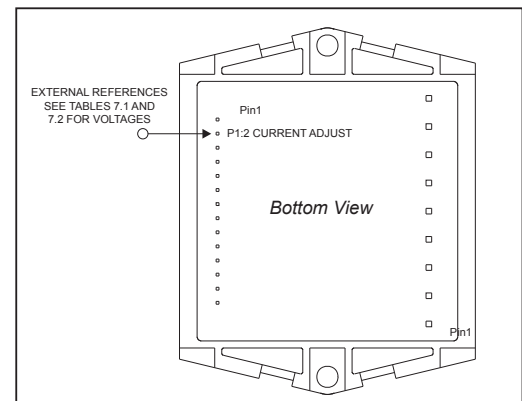

Figure 6.3: Setting the Output Current using an External Source

Current Adjust Resistor and Reference Values

Current Adjust Resistor and Reference Values for the IM483H Plus		
Ouput Current (Amps Peak)	Reference (Volts)	Resistor Value (1% Ohms)
0.4	0.2	200
0.6	0.3	301
0.8	0.4	392
1.0	0.5	499
1.2	0.6	550
1.4	0.7	698
1.6	0.8	787
1.8	0.9	887
2.0	1.0	1000
2.2	1.1	1100
2.4	1.2	1210
2.6	1.3	1300
2.8	1.4	1400
3.0	1.5	1500
3.2	1.6	1580
3.4	1.7	1690
3.6	1.8	1780
3.8	1.9	1910
4.0	2.0	2000

Table 6.1: Current Adjust Reference/Output Current (IM483H Plus)

Current Adjust Resistor and Reference Values for the IM805H Plus		
Ouput Current (Amps Peak)	Reference (Volts)	Resistor Value (1% Ohms)
1.0	0.15	150
1.2	0.18	182
1.4	0.21	210
1.6	0.24	243
1.8	0.27	267
2.0	0.30	301
2.2	0.33	332
2.4	0.36	357
2.6	0.39	392
2.8	0.42	422
3.0	0.45	453
3.2	0.48	475
3.4	0.51	511
3.6	0.54	536
3.8	0.57	562
4.0	0.60	604
4.2	0.63	634
4.4	0.66	665
4.6	0.69	698
4.8	0.72	715
5.0	0.75	750
5.2	0.78	787
5.4	0.81	806
5.6	0.84	845
5.8	0.87	866
6.0	0.90	909
6.2	0.93	931
6.4	0.96	953
6.6	0.99	1000
6.8	1.02	1020
7.0	1.05	1050

Table 6.2: Current Adjust Reference/Output Current (IM805H Plus)

Reducing/Disabling the Output Current

The IM483H Plus/IM805H Plus will automatically reduce the current in the motor windings after a move provided the on board 1mA current source, along with a current adjustment resistor, is used to set the output current and a resistor is placed between pins 2 and 3 of connector P1. Using this will greatly reduce the amount of motor and drive heating in your system.

The amount of current reduced will depend upon the value of the Reduction Adjust Resistor (R_{Red}) and the value of the current adjust resistor (R_{Adj}). The Current will be reduced 0.5 seconds after the rising edge of the last Step Clock Pulse. The value of R_{Red} is calculated as follows:

IM483H Plus Current Reduction



I_{Run} is the desired peak running current.
Range 0.4A to 4A Peak

I_{Hold} is the desired peak holding current.
Range 0.2A to 4A Peak

$$R_{Red} = 500 \times \frac{I_{Run} \times I_{Hold}}{(I_{Run} - I_{Hold})}$$

IM805H Plus Current Reduction



I_{Run} is the desired peak running current.
Range 1.0A to 7A Peak

I_{Hold} is the desired peak holding current.
Range 0.5A to 7A Peak

$$R_{Red} = 150 \times \frac{I_{Run} \times I_{Hold}}{(I_{Run} - I_{Hold})}$$

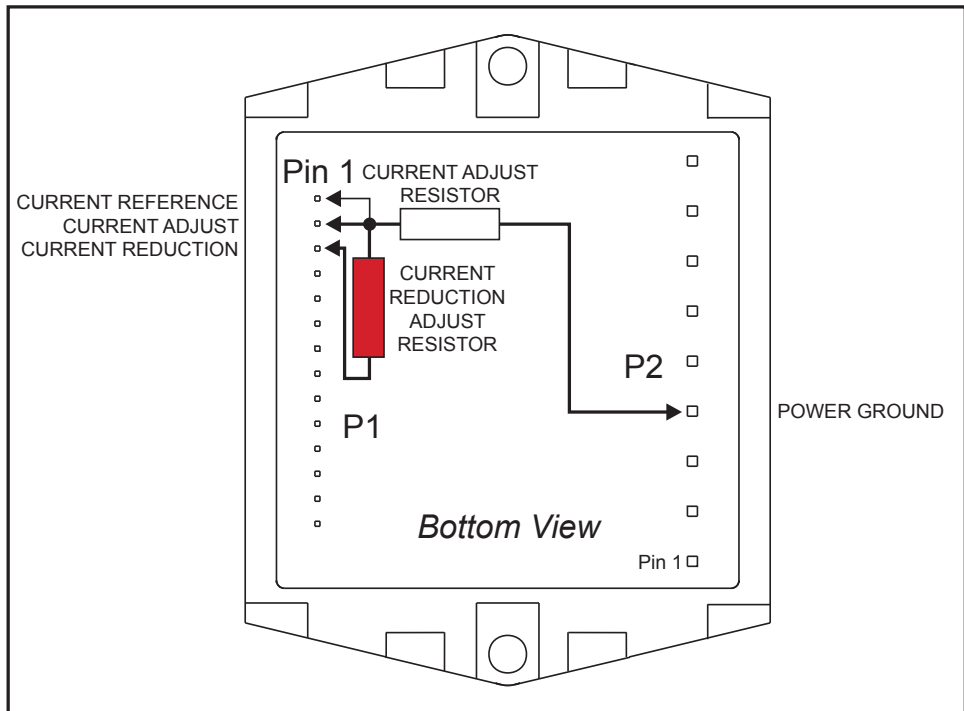

Figure 6.4: Current Reduction Adjustment Resistor Connection

If zero current is required at stand still then the current reduction output (P1:3) may be tied directly to the enable input (P1:11). This will disable the outputs 0.5 seconds after the last step clock input.

When the current reduction output is used in this manner an open collector output or blocking diode is **REQUIRED** or damage may occur to the internal circuitry. The diode or open collector transistor should be placed after the enable/reduction connection as shown in Figure 6.5.

If a voltage is used to set the output current the current reduction output (P1:3) will provide an open drain, active low output that occurs 0.5 seconds after the last step clock input and is referenced to ground (P2:4) the $R_{DS_{ON}}$ of the internal MOSFET is approximately 6.5Ω.

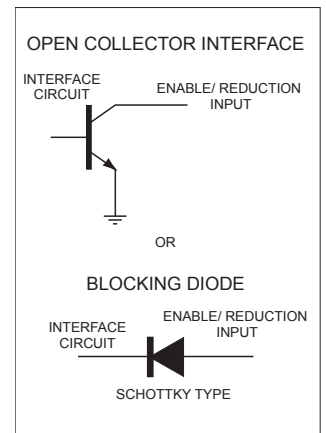

Figure 6.5: Interfacing the Current Reduction Input

Interfacing the IM483H Plus/IM805H Plus Inputs

The inputs to the IM483H Plus/IM805H Plus are internally pulled up to the +5VDC supply. Figure 6.6 shows the inputs and their associated pull up resistor values.

When interfacing to the IM483H Plus/IM805H Plus logic inputs an open collector output is recommended.

The Microstep Resolution Select Inputs (MSEL)

Microsteps per step are selected via Pins 5 - 8 on connector P1. The table below shows the standard resolution values and the associated input settings.

The microstep resolution can be changed at any time. There is no need to reset the drive or cycle the power. On-the-fly “gear shifting” facilitates high speed slewing combined with high resolution positioning at either end of the move.

When the microsteps are changed so that the IM483H Plus/IM805H Plus does not fall on a full step (i.e. zero crossing of the sine/cosine) the IM483H Plus/IM805H Plus will readjust itself at the next pulse that would overshoot the fullstep position. This feature allows the IM483H Plus/IM805H Plus to readjust the motor position no matter what resolution is chosen when it is changed.

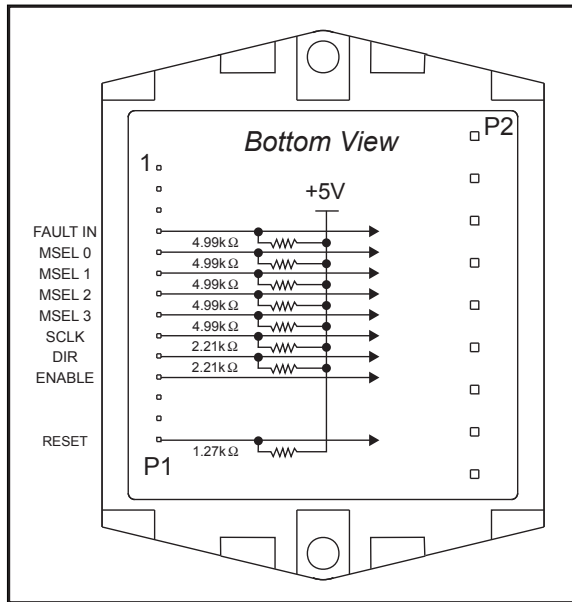

Figure 6.6: Input Pull-Up Resistors

Microstep Resolution (MSEL) Settings					
RESOLUTION (Microsteps/Step)	STEPS/REV (1.8° Step Motors)	MSEL 0 (P1:5)	MSEL 1 (P1:6)	MSEL 2 (P1:7)	MSEL 3 (P1:8)
BINARY					
2	400	LOW	LOW	LOW	LOW
4	800	HIGH	LOW	LOW	LOW
8	1,600	LOW	HIGH	LOW	LOW
16	3,200	HIGH	HIGH	LOW	LOW
32	6,400	LOW	LOW	HIGH	LOW
64	12,800	HIGH	LOW	HIGH	LOW
128	25,600	LOW	HIGH	HIGH	LOW
256	51,200	HIGH	HIGH	HIGH	LOW
DECIMAL					
5	1,000	LOW	LOW	LOW	HIGH
10	2,000	HIGH	LOW	LOW	HIGH
25	5,000	LOW	HIGH	LOW	HIGH
50	10,000	HIGH	HIGH	LOW	HIGH
125	25,000	LOW	LOW	HIGH	HIGH
250	50,000	HIGH	LOW	HIGH	HIGH
FULL STEP					
1	200	LOW	HIGH	HIGH	HIGH
DEGREES					
180	36,000	HIGH	HIGH	HIGH	HIGH

Table 6.3: Microstep Resolution Select Settings

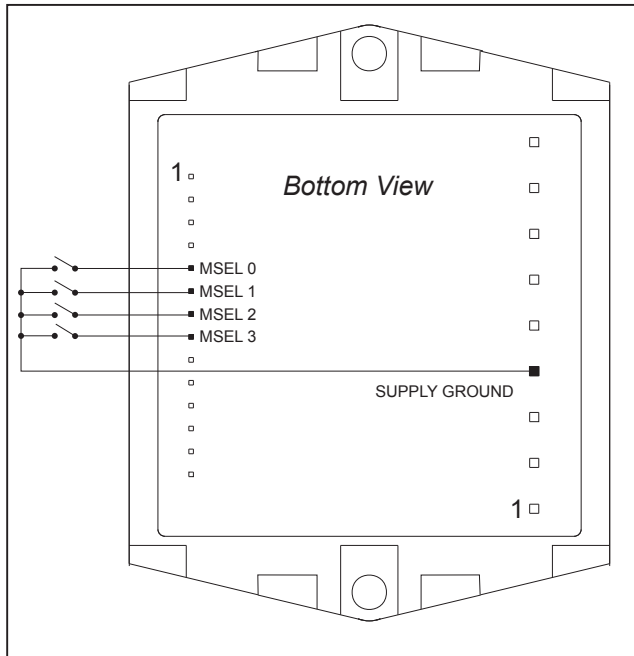

Figure 6.7: MSEL Inputs, Interface Example

Interfacing the Fault and Reset Inputs



WARNING!
When interfacing the FAULT IN/RESET input, an open collector, tri-state output or blocking diode is REQUIRED or damage may occur. (See Figure 6.10.)

The IM483H Plus/IM805H Plus has a Fault input located at P1:4. This can be used to force a fault condition. When pulled low the signal is latched and the outputs will be disabled. The fault condition can only be cleared by resetting the drive or cycling the power.

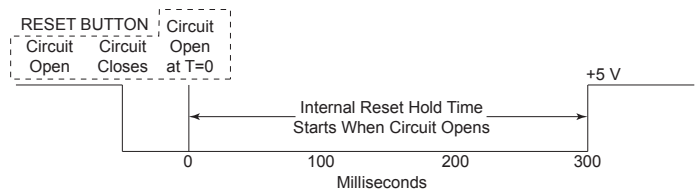

Figure 6.8: Reset Timing

When interfacing this input, an open collector output or blocking diode is REQUIRED or damage may occur to the internal fault detection circuitry.

The IM483H Plus/IM805H Plus also has a Reset Input. On power up, or if the Reset Input is Closed, the internal reset circuit will hold the input low for 100 to 300 milliseconds. The “holding” time does not begin until the Reset Input is Opened. (See Figure 6.9.)

When controlling multiple drives with a single Reset you must install blocking diodes at the input (Pin 14) of each drive. Because of the slight differences in Reset timing, this will prevent the drives from latching the Reset Input in the LOW state. (See Figure 6.10.)

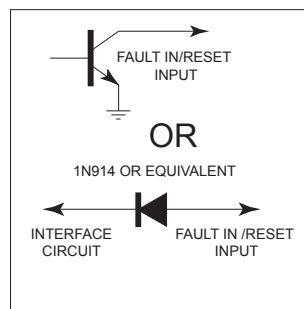

Figure 6.9: Interfacing the Fault In/Reset Inputs

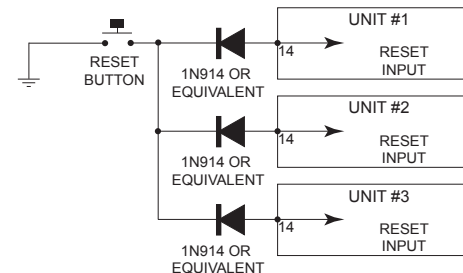

Figure 6.10: Multiple Drives - One Reset

Minimum Connections

The following figure and table illustrate the minimum connection requirements for the IM483H Plus and IM805H Plus drivers.

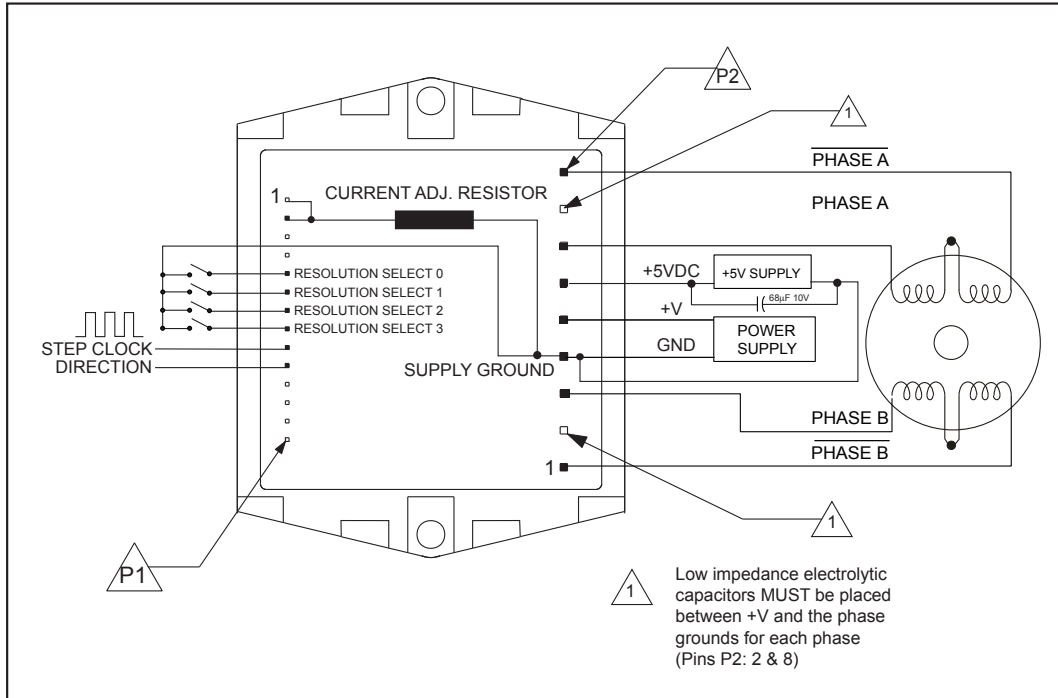

Figure 6.11: IM483H Plus/IM805H Plus Minimum Connections

IM483H Plus/IM805H Plus Minimum Required Connections		
Connector P1		
Pin #	Pin Name	
7, 9	Phase A	Phase A Motor Output
1, 3	Phase B	Phase B Motor Output
4	Ground	Power Supply Return
5	+V	Power Supply +Voltage Input
6	+5 VDC	+5 VDC Input
Connector P2		
1, 2	Current Adjust	Phase Current Adjustment Input
10	Direction	Motor Direction input
9	Step Clock	Motor Step Clock Inputs
5 - 8	MSEL 0 - 3	Microstep Resolution Select Lines

Table 6.4: Minimum Connections

Page Intentionally Left Blank

Appendix A

Troubleshooting

Section Overview

This section will cover the following:

- Basic Troubleshooting.
- Common Problems/Solutions.
- Contacting Application Support.
- Product Return Procedure.

Basic Troubleshooting

In the event that your IM483H Plus/IM805H Plus doesn't operate properly, the first step is to identify whether the problem is electrical or mechanical in nature. The next step is to isolate the system component that is causing the problem. As part of this process you may have to disconnect the individual components that make up your system and verify that they operate independently. It is important to document each step in the troubleshooting process. You may need this documentation to refer back to at a later date, and, these details will greatly assist one of our application engineers in determining the problem should you need assistance.

Many of the problems that effect motion control systems can be traced to electrical noise, software errors, or mistakes in wiring.

Common Problems and Solutions

Symptom: Motor does not move.

Possible Problem

- No power.
- Unit is in a reset condition.
- Invalid microstep resolution select setting.
- Current adjust resistor is wrong value or not in place.
- Fault condition exists.
- Unit is disabled.

Symptom: Motor moves in the wrong direction.

Possible Problem

- Motor phases may be connected in reverse.

Symptom: Unit in fault.

Possible Problem

- Current adjust resistor is incorrect value or not in place.
- Motor phase winding shorted.
- Power input or output driver electrically overstressed.
- Unit overheating.

Symptom: Erratic motor motion.

Possible Problem

- Motor or power wiring unshielded or not twisted pair.
- Logic wiring next to motor/power wiring.
- Ground loop in system.
- Open winding of motor.
- Phase bad on drive.

Symptom: Motor stalls during acceleration.

Possible Problem

- Incorrect current adjust setting or resistor value.
- Motor is undersized for application.
- Acceleration on controller is set to high.
- Power supply voltage too low.

Symptom: Excessive motor and driver heating.

Possible Problem

- Inadequate heat sinking / cooling.
- Current reduction not being utilized.
- Current set too high.

Symptom: Inadequate holding torque.

Possible Problem

- Incorrect current adjust setting or resistor value.
- Increase holding current with the current reduction adjust resistor.

Contacting Application Support

In the event that you are unable to isolate the problem with your IM483H Plus/IM805H Plus, the first action you should take is to contact the distributor from whom you originally purchased your product or Novanta IMS Application Support at 860-295-6102. Be prepared to answer the following questions:

- What is the application?
- In detail, how is the system configured?
- What is the system environment? (Temperature, Humidity, Exposure to chemical vapors, etc.)
- What external equipment is the system interfaced to?

Another product support resource is the Novanta IMS website located at www.novantaims.com for tech tips, applications and new product updates.

Returning Your Product to Novanta IMS

If Application Support determines that your IM483H Plus/IM805H Plus needs to be returned the factory for repair or replacement you will need to take the following steps:

- Obtain an RMA (Returned Material Authorization) number and shipping instructions at <https://novantaims.com/contacts/request-rma/>
- Enclose the product being returned in its original container if possible. If original packaging is unavailable ensure that the product is enclosed in approved antistatic packing material. Write the RMA number on the box.

The normal repair lead time is 10 business days, should you need your product returned in a shorter time period you may request that a "HOT" status be placed upon it while obtaining an RMA number. Should the factory determine that the product repair is not covered under warranty, you will be notified of any charges.

Appendix B

The IM483H Plus/IM805H Plus Developer's Kit

Section Overview

This appendix covers the optional developer's kit for the IM483H Plus and IM805H Plus Microstepping Hybrids. (Novanta IMS Part Numbers IM483H Plus-DK1 and IM805H Plus-DK1.)

The Developer's Kit provides all of the tools needed for rapid prototyping and product evaluation by eliminating the need of laying out and testing a PC board and heat sink proofing. The included interface board features an on board +5V supply, fault protection, opto isolation for logic inputs, and screw terminals for easy prototyping. The inclusion of the interface board schematic provides a useful guide for PC board layout when completing a system design using the IM483H Plus/IM805H Plus Hybrid.

Included in the Developer's Kit are:

- IM483H Plus or IM805H Plus Hybrid Driver.
- INT-483H/INT-805H Interface Board.
- HFC-22 Heat Sink/Fan/Clip Assembly.
- Interface Board Schematic.

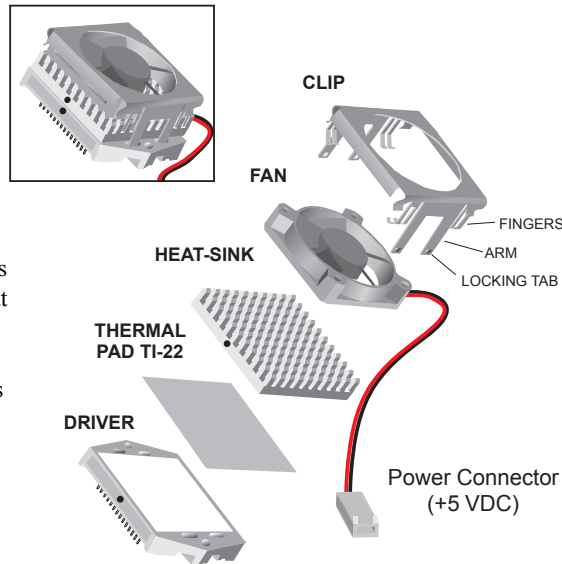

Figure B.1: IM483H Plus-DK1/IM805H Plus-DK1

Assembling the HFC-22 Heat Sink/Fan Clip Assembly

To assemble:

- 1) Place the heat sink on the driver, align so that the dot on the heat sink is on the same side as the dot on the driver, with the TI-22 thermal pad sandwiched between them.
- 2) Insert two of the arms from the fan/clip assembly into the corresponding slots in the driver, aligning the curved fingers on the clip between the posts of the heat sink. Insert the other two locking tabs into the opposite slots and snap into place. The locking tabs on all four arms should be completely through the slots on the driver.
- 3) Plug assembled HFC-22/driver into interface board.



Interface Board

One of the key components of the IM483H Plus - DK1/IM805H Plus-DK1 is the interface board INT-483H/INT-805H. The interface board was designed to aid the user in rapid integration of the IM483H Plus or IM805H Plus driver hybrid into your system.

The key features of the interface board are:

- Optically Isolated Logic Inputs.
- Fault Output.
- +5VDC Supply.
- Screw Terminals.
- Power and Fault LEDs.
- Input Capacitors.

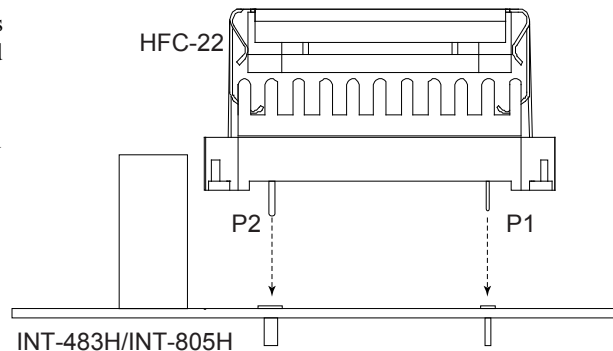

Figure B.2: HFC-22 Exploded View

Pin Assignment and Descriptions

INT-483H/INT-805H Pin Assignment		
Connector P1: 7 Pin Screw Terminal		
Pin #	Pin Name	Description
1, 2	Phase A	Phase A Motor Output
3, 4	Phase B	Phase B Motor Output
5, 6	Ground	Power Supply Return
7	+V	Power Supply +Voltage Input
Connector P2		
1	Opto Supply	Optocoupler Power Supply (+5 to +24 VDC)
2	Current Reduction	Phase Current Reduction Input
3	Current Adjust	Phase Current Adjust Input
4	GND	Ground
5	Reset	Active when LOW Reset input
6	Enable	Active when HIGH Motor Phase Enable Input
7	Direction	Motor Direction Input
8	Step Clock	Motor Step Clock
9	Full Step	Open Drain On-Full-Step Input
10	Fault	Open Drain Fault Output

Table B.1: INT-483 / INT-805 Pin Assignment and Descriptions

Electrical Specifications

The test parameters for the following are: $T_A = 25^\circ\text{C}$, +V = 45VDC

INT-483H/INT-805H DC Electrical Specifications						
Specification	Test Condition	Min	Typ	Max	Unit	
Opto Supply	Isolated Inputs	5		40	V	
Input Forward Current	Isolated Inputs	8	10	12	mA	
Opto Input Forward Voltage	Isolated Inputs		1.5	1.7	V	
Reverse Breakdown Voltage	Isolated Inputs	5			V	
Signal Output Current	On-Full-Step, Fault			25	mA	
Drain-Source Voltage	On-Full-Step, Fault			100	V	
Drain-Source Resistance	On-Full-Step, Fault ($I_{DS} = 25\text{mA}$)		6.5		Ω	

Table B.2: INT-483 / INT-805 Interface Board Electrical Characteristics

Dimensional Information

The INT-483H/INT-805H can be mounted to a panel using standard #8 hardware.

Dimensions in Inches (mm)

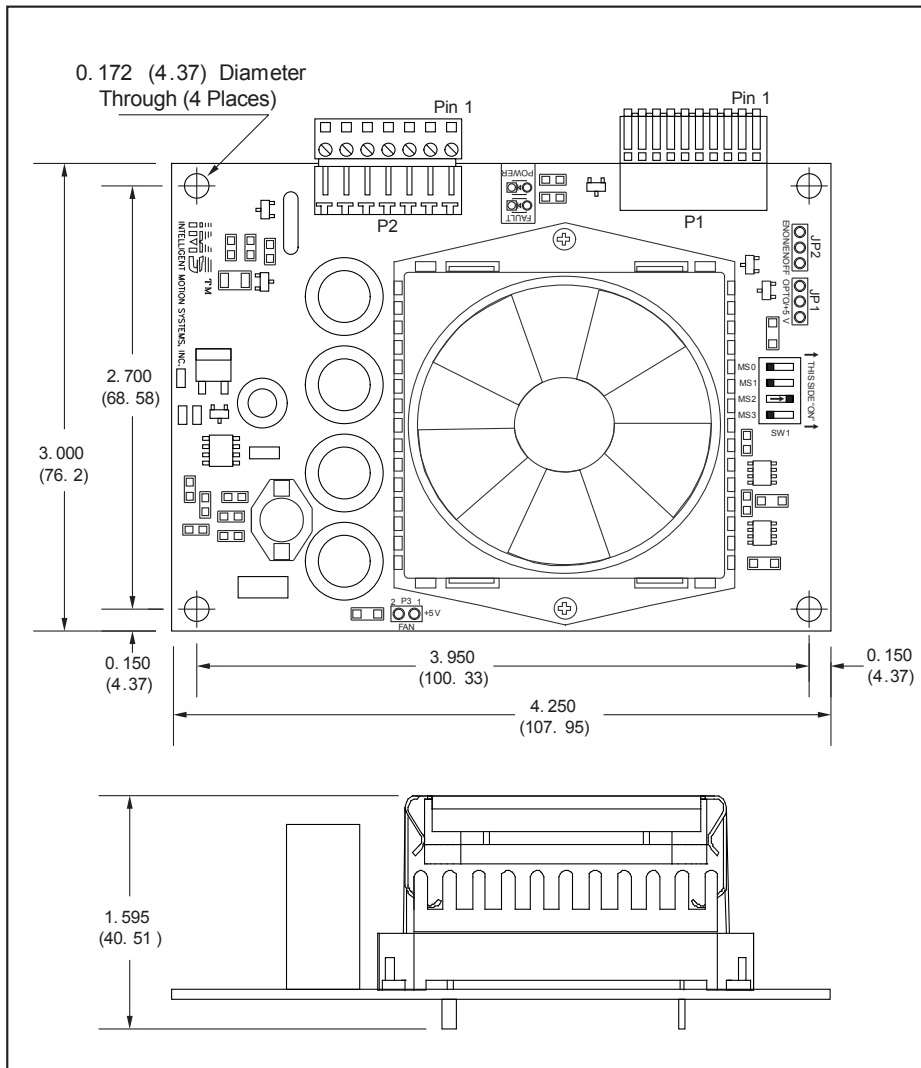

Figure B.3: INT-483 / INT-805 Interface Board Dimensions



WARNING! When using the “ENON” mode of disabling the outputs following a move the current reduction resistor **MUST NOT** be used or the drive will operate erratically.



NOTE: When connecting both the current adjust and the current reduction resistors, connections should be made as short as possible to minimize the amount of electrical noise coupled into the driver.



NOTE: When using the on-board +5VDC supply (JP1:2-3) to power the opto-isolators, electrical isolation between drive/fan power and the logic inputs is defeated!

Setting the Output Current

The INT-483H/INT-805H uses the IM483H Plus or IM805H Plus’s internal current source to adjust the output current of the driver. In order to calculate the run and hold currents for the driver being used, please refer to Section 6: Interfacing to the IM483H Plus/IM805H Plus of this document. The figure below illustrates the resistor connections for both run and hold currents.

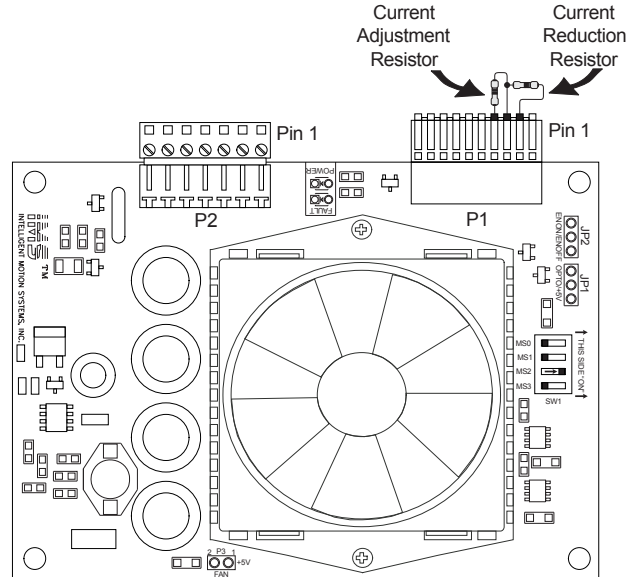

Figure B.4: INT-483 / INT-805 Current Adjustment Resistors

Jumper Settings

JP2:1-2: If the shunt is placed on the “ENON” side of the jumper (between pins 1 & 2) the drive outputs will be disabled approximately 0.5 seconds after the last step clock input. Note that in this mode of operation the current reduction resistor **MUST NOT** be used or the drive will operate erratically. This mode should only be used if no holding current is required.

JP2:2-3: If the shunt is placed on the “ENOFF” side of the jumper (between pins 2 & 3) the drive outputs will not disable following the last step clock pulse. In this case a current reduction resistor can be used to set the holding current to some value. The jumper is illustrated in Figure B.5.

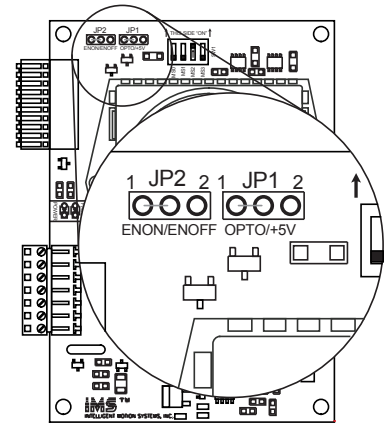

Figure B.5: Jumpers JP1 & JP2

Isolated Inputs

The schematic illustrated in Figure B.6 shows the optically isolated inputs to the INT-483H/INT-805H and associated circuitry.

Jumper Settings

JP1:1-2: If the shunt is placed on the “OPTO” side (between pins 1 & 2) of the jumper, the power for the opto-isolators (+5 to +24VDC) must be provided by the user at P1:1.

JP1:2-3: If the shunt is placed on the “+5V” side (between pins 2 & 3), then the opto-isolators will be powered by the on board +5V supply. If the on-board supply is used to power the opto-isolators, electrical isolation between drive power and the logic inputs will be lost.

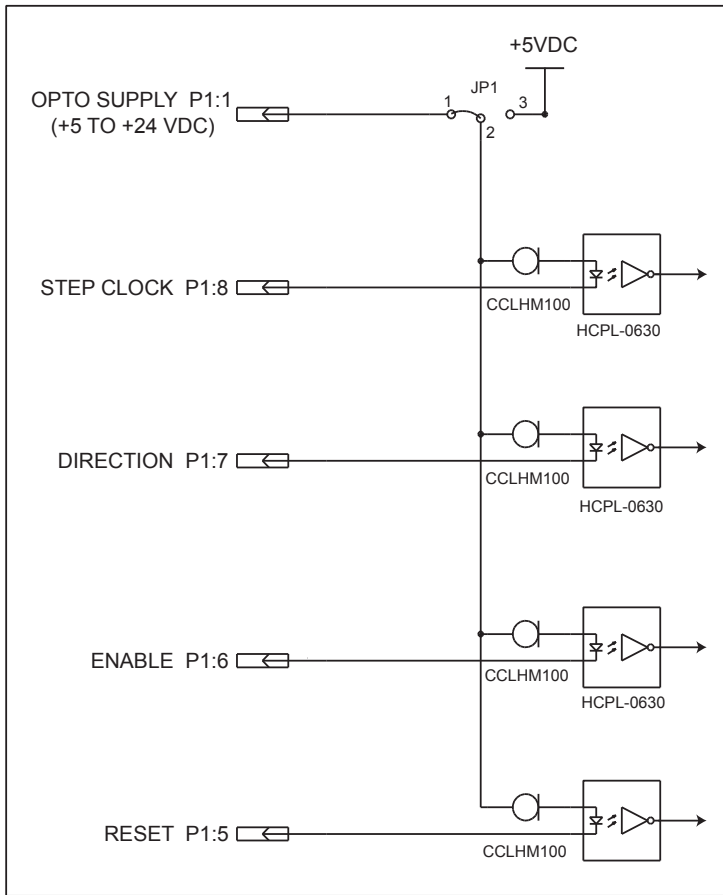

Figure B.6: Opto Isolated Inputs

Microstep Resolution Settings

The number of microsteps per step is selected by the DIP switch (SW1). The following table shows the standard resolution values along with the associated switch settings.

Please note that all of the example settings are for a stepper motor with 1.8° step angle. If using a motor with a different step angle the steps/rev resolution will vary with the step angle.

For example, a 0.9° step angle motor (400 Fullsteps/Rev) set to 16 microsteps/step will have a resolution of 6,400 steps/rev.

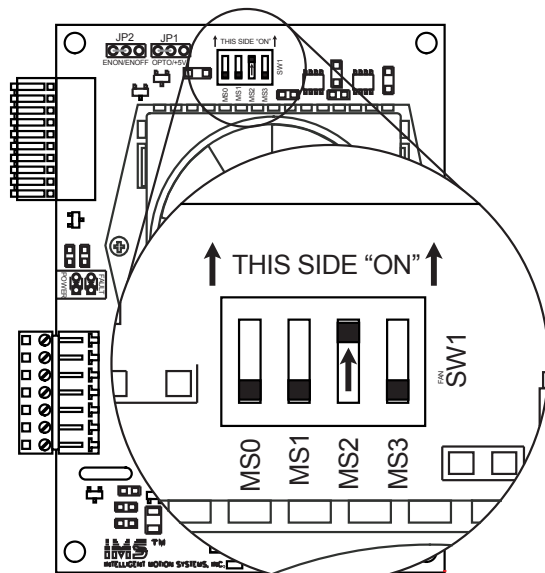

Figure B.7: MSEL Select Switch

Microstep Resolution (MSEL) Settings					
RESOLUTION (Microsteps/Step)	STEPS/REV (1.8° Step Motors)	MSEL 0 (P1:5)	MSEL 1 (P1:6)	MSEL 2 (P1:7)	MSEL 3 (P1:8)
BINARY					
2	400	OFF	OFF	OFF	OFF
4	800	ON	OFF	OFF	OFF
8	1,600	OFF	ON	OFF	OFF
16	3,200	ON	ON	OFF	OFF
32	6,400	OFF	OFF	ON	OFF
64	12,800	ON	OFF	ON	OFF
128	25,600	OFF	ON	ON	OFF
256	51,200	ON	ON	ON	OFF
DECIMAL					
5	1,000	OFF	OFF	OFF	ON
10	2,000	ON	OFF	OFF	ON
25	5,000	OFF	ON	OFF	ON
50	10,000	ON	ON	OFF	ON
125	25,000	OFF	OFF	ON	ON
250	50,000	ON	OFF	ON	ON
FULL STEP					
1	200	OFF	ON	ON	ON
DEGREES					
180	36,000	ON	ON	ON	ON

Table B.3: Microstep Resolution Switch Settings

LED Indicators

Green

The green LED is powered by the on-board +5V supply and indicates a “power on” condition when illuminated.

Red

The red LED is controlled by the fault output of the IM483H Plus or IM805H Plus driver. If the red LED is illuminated turn off the power and check for a system fault. A fault condition can only be reset by cycling power or toggling the RESET input at P1:6. In the case of an over-temperature fault allow the drive to cool before re-applying power.

Fault Protection

The INT-483H/INT-805H adds phase to ground fault protection to the IM483H Plus or IM805H Plus. If a phase to ground fault is detected the driver will set the fault output, which will illuminate the red LED.

The INT-483H/INT-805H buffers the drivers fault output signal through an open drain N-channel FET. The signal at the terminal strip is inverted, thus it is active LOW.

In the case of an over-temperature fault, neither the red LED or the fault output will activate. The driver must be allowed to cool prior to re-applying power. If this type of fault condition occurs verify that the HFC-22 is properly seated and the fan is working.

The power must be cycled or the reset input toggled to clear the fault condition.

Full Step Output

The INT-483H/INT-805H buffers the driver's full step output signal through an open drain N-channel FET. The signal at the terminal strip is inverted, thus it is active LOW.

Minimum Connections for the IM483H Plus-DK1/IM805H Plus-DK1

The figure below illustrates the minimum connections to the IM483H Plus/IM805H Plus-DK1.

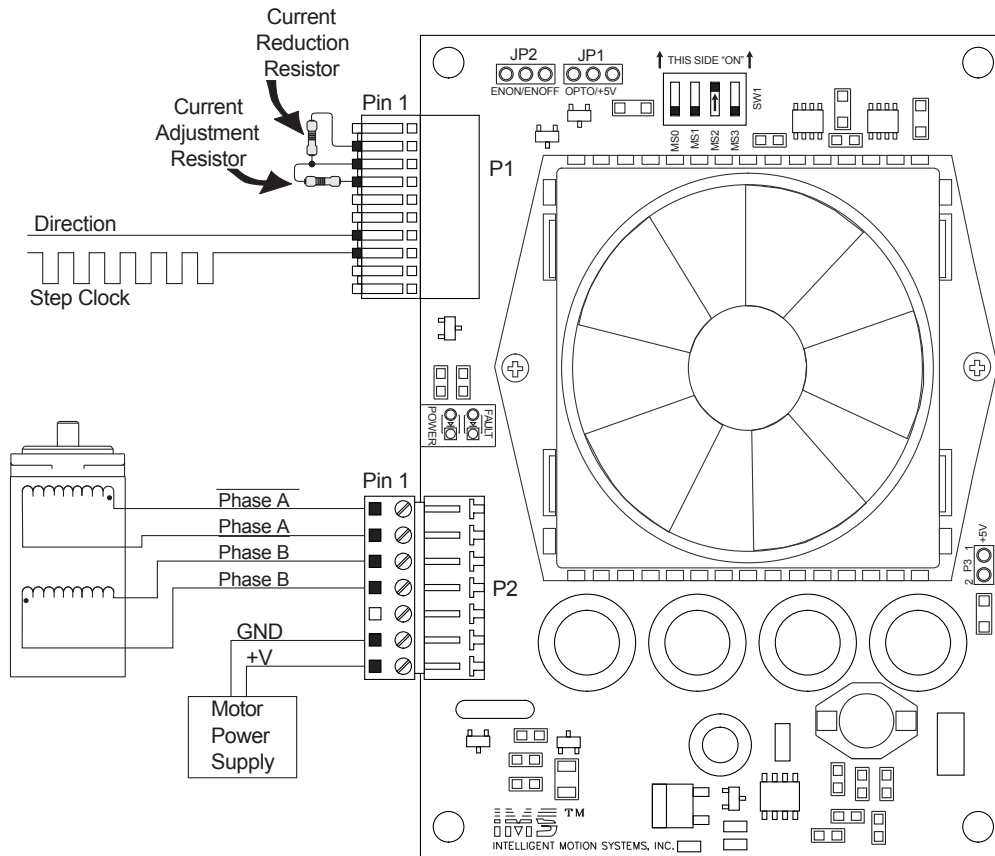

Figure B.8: Minimum Connections

Appendix C

Recommended Cable Configurations

N **NOTE:** These recommendations will provide optimal protection against EMI and RFI. The actual cable type, wire gauge, shield type and filtering devices used are dependent on the customer's application and system.

N **NOTE:** Always use Shielded/Twisted Pairs for the Novanta IMS Driver DC Supply Cable, the AC Supply Cable and the Novanta IMS Driver to Motor Cable.

DC Power To Novanta IMS Driver

Cable length, wire gauge and power conditioning devices play a major role in the performance of your Novanta IMS Driver and Motor.

NOTE: The length of the DC power supply cable to the Novanta IMS Driver should not exceed 50 feet.

Example A demonstrates the recommended cable configuration for DC power supply cabling under 50 feet long. If cabling of 50 feet or longer is required, the additional length may be gained by adding an AC power supply cable (see Examples B & C).

Correct AWG wire size is determined by the current requirement plus cable length. Please see the Novanta IMS Driver

Supply Cable AWG Table in this Appendix.

Example A – Cabling Under 50 Feet, DC Power

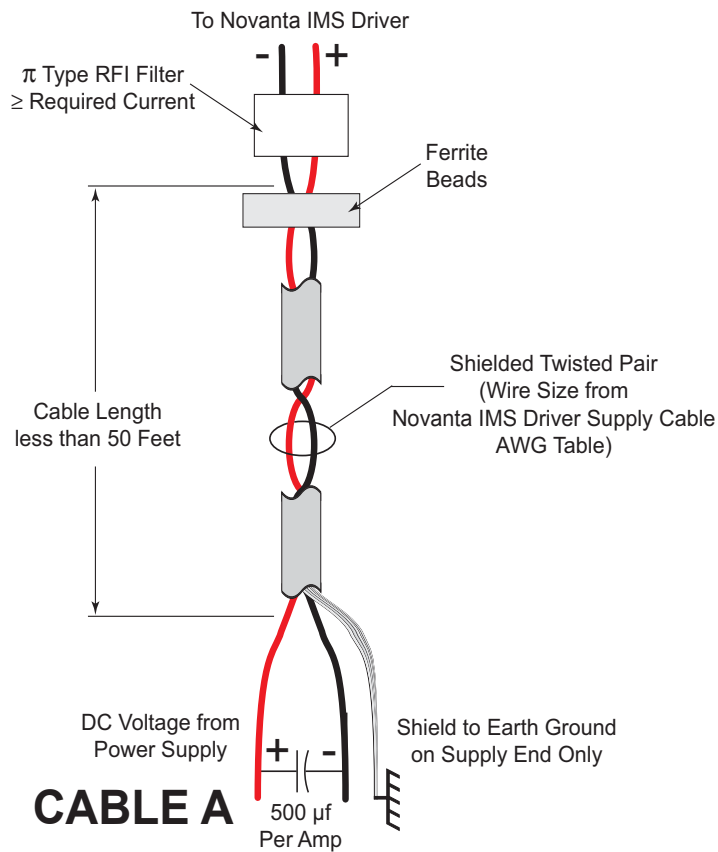

Figure C.1: DC Cabling Under 50 Feet

Example B – Cabling 50 Feet or Greater, AC Power to Full Wave Bridge

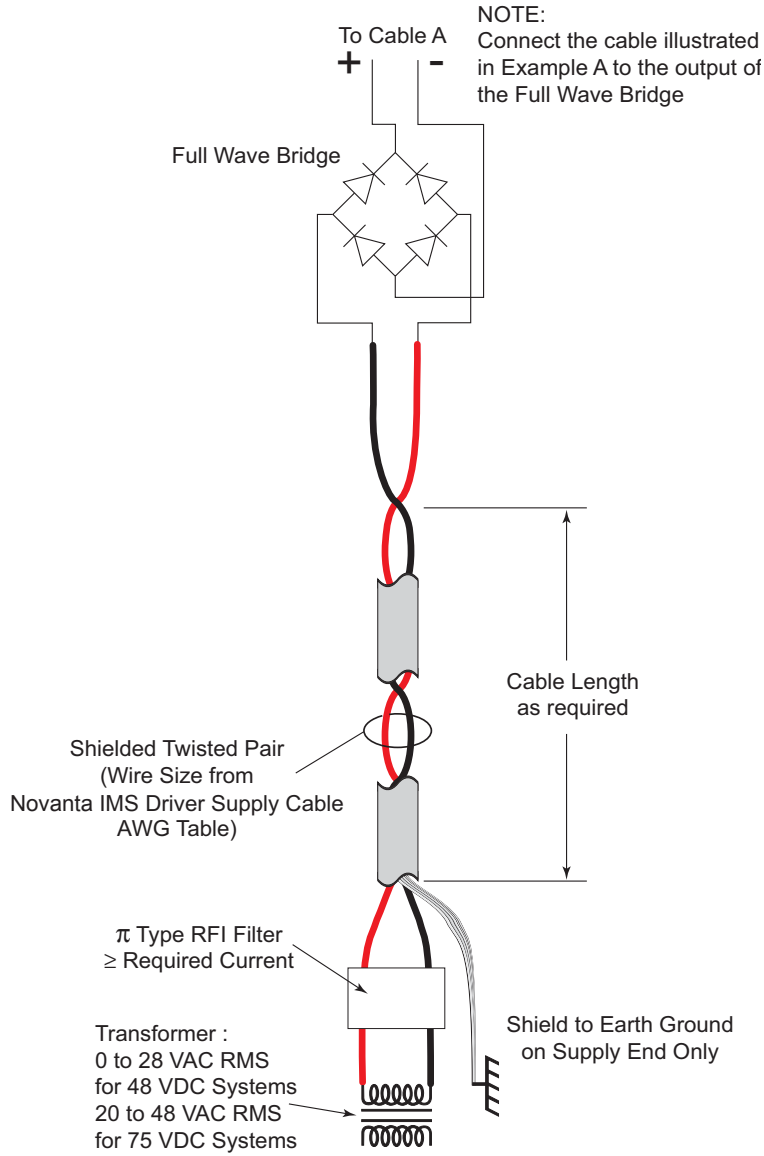

Figure C.2: Cabling 50 Feet or Greater, AC Power to Full Wave Bridge

Example C – Cabling 50 Feet or Greater, AC Power to Power Supply

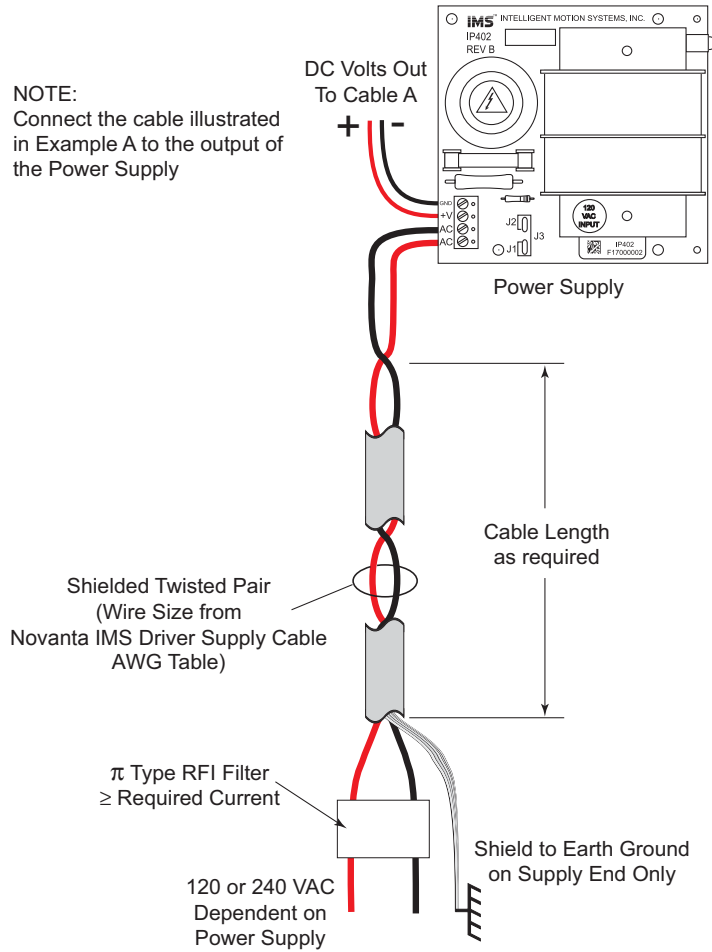

Figure C.3: Cabling 50 Feet or Greater, AC Power to Motor Power Supply

Novanta IMS Driver Supply Cable AWG Table					
1 Ampere (Peak)					
Length (Feet)	10	25	50*	75*	100*
Minimum AWG	20	20	18	18	16
2 Amperes (Peak)					
Length (Feet)	10	25	50*	75*	100*
Minimum AWG	20	18	16	14	14
3 Amperes (Peak)					
Length (Feet)	10	25	50*	75*	100*
Minimum AWG	18	16	14	12	12
4 Amperes (Peak)					
Length (Feet)	10	25	50*	75*	100*
Minimum AWG	18	16	14	12	12
* Use the alternative methods innustrated in Examples B and C when the cable length is \geq 50 feet. Also, use the same current rating when the alternate AC power is used.					

Table C.1: Driver Supply Cable Wire Size

Motor Driver to Motor

Cable length, wire gauge and power conditioning devices play a major role in the performance of your Novanta IMS Driver and Motor.

NOTE: The length of the DC power supply cable between the Novanta IMS Driver and the Motor should not exceed 50 feet.

Example A demonstrates the recommended cable configuration for the Novanta IMS Driver to Motor cabling under 50 Feet long. If cabling of 50 feet or longer is required, the additional length can be gained with the cable configuration in Example B.

Correct AWG wire size is determined by the current requirement plus cable length. Please see the Novanta IMS Driver to Motor Cable AWG Table in this Appendix.

Example A - Cabling Under 50 Feet, Novanta IMS Driver to Motor

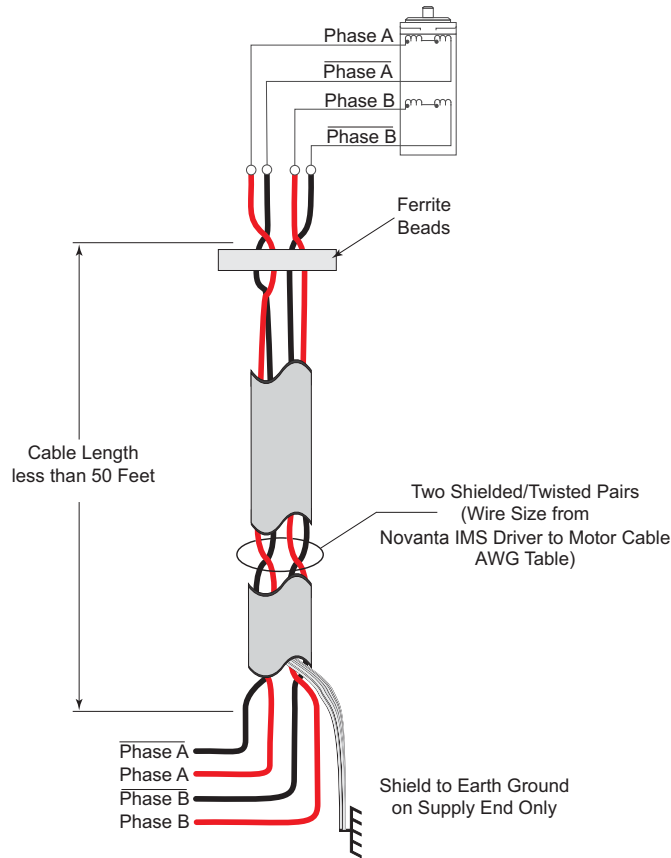
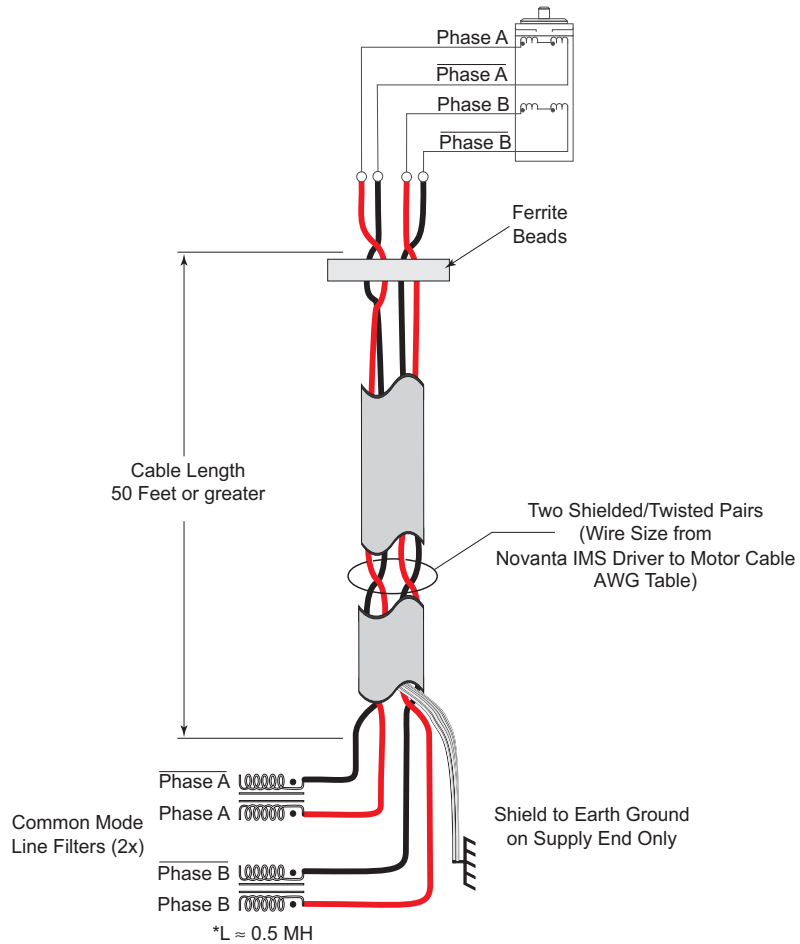

Figure C.4: Cabling Under 50 Feet, Novanta IMS Driver to Motor

Example B - Cabling 50 Feet or Greater, Novanta IMS Driver to Motor



* 0.5 MH is a typical starting point for the Common Mode Line Filters. By increasing or decreasing the value of L you can set the drain current to a minimum to meet your requirements.

Figure C.5: Cabling Under 50 Feet, Novanta IMS Driver to Motor

Novanta IMS Driver to Motor Cable AWG Table											
1 Ampere (Peak)					5 Amperes (Peak)						
Length (Feet)	10	25	50*	75*	100*	Length (Feet)	10	25	50*	75*	100*
Minimum AWG	20	20	18	18	16	Minimum AWG	16	16	14	12	12
2 Amperes (Peak)					6 Amperes (Peak)						
Length (Feet)	10	25	50*	75*	100*	Length (Feet)	10	25	50*	75*	100*
Minimum AWG	20	18	16	14	14	Minimum AWG	14	14	14	12	12
3 Amperes (Peak)					7 Amperes (Peak)						
Length (Feet)	10	25	50*	75*	100*	Length (Feet)	10	25	50*	75*	100*
Minimum AWG	18	16	14	12	12	Minimum AWG	12	12	12	12	12
4 Amperes (Peak)											
Length (Feet)	10	25	50*	75*	100*						
Minimum AWG	18	16	14	12	12						
* Use the alternate method illustrated in Example B when cable length is ≥ 50 feet.											

Table C.2: Driver Supply Cable Wire Size

Appendix D

Application and Usage Examples

Electronic "Gear Shifting"

Electronic Gear Shifting applications use the IM483 Plus/IM805 Plus ability to change the Microstep Resolution on the fly. Using solid state outputs of a PLC or other control device allows the system to "Shift Gears" by changing the state of the Microstep Resolution Select inputs (MSEL 0 - 3).

In the example shown below, the control device will change the microstep resolution from 256 μ steps/step to 128 μ steps/step, doubling the motor velocity.

Note: Use solid state, not mechanical switching.

Note 2: The below diagram is for illustration purposes only, additional circuitry may be required between your control interface and the IMxH Plus Product.

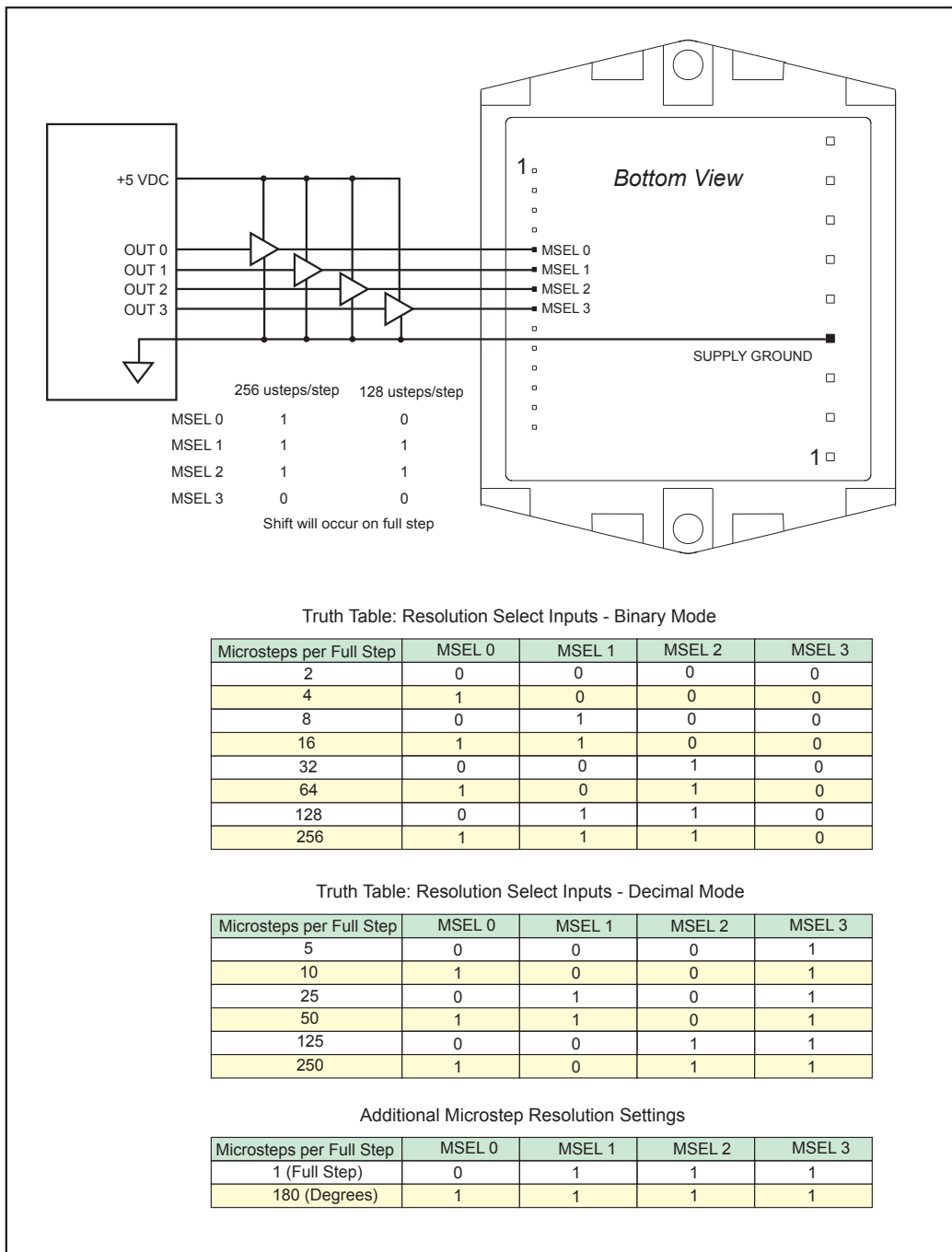

Figure D.1: Electronic Gear Shifting Application Example

Speed Control with Following on a Second Axis using the OSC-805H

The IM805H Plus has available as an option the OSC-805H Speed Control Interface, which allows the user to use a 0 to +5 VDC, 4 to 20mA/0 to 20mA, or 15 to 25 kHz PWM to control the axis velocity.

All speed control parameters are set using a simple user interface, Novanta IMS SPI Motor Interface, downloadable from the Novanta IMS web site at www.novantaims.com.

In the application example below, the OSC-805H/IM805H Plus are used as a primary axis. Primary axis velocity is controlled by a 15-25 kHz PWM Output on a PLC, The step and direction outputs of the OSC-805H are used to drive a second axis, following the primary.

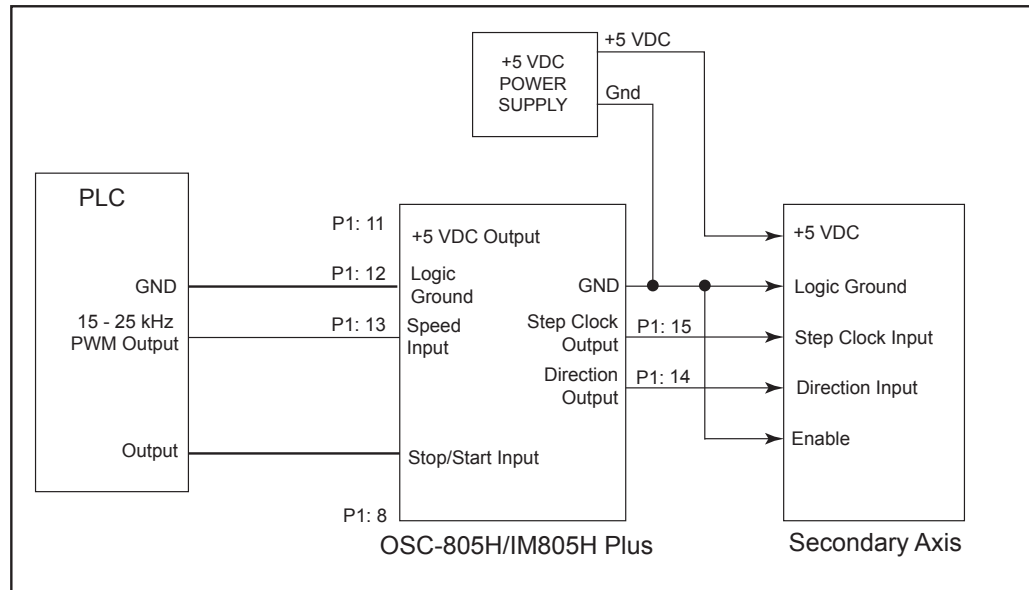

Figure D.2: Speed Control Application

Using The Full Step Output to Show Axis Position

The IM483H Plus/IM805H Plus features an On-Full-Step output. This totem-pole output will send a HIGH Pulse when the motor is positioned at Full Step regardless of the number of microsteps in between.

The below application example illustrates a simple counter system that would track the position of the axis in Full Steps. The state of the Direction input will determine the up/down state of the counter.

The below diagram is for illustration purposes only, additional circuitry may be required between your control interface and the IMxH Plus Product.

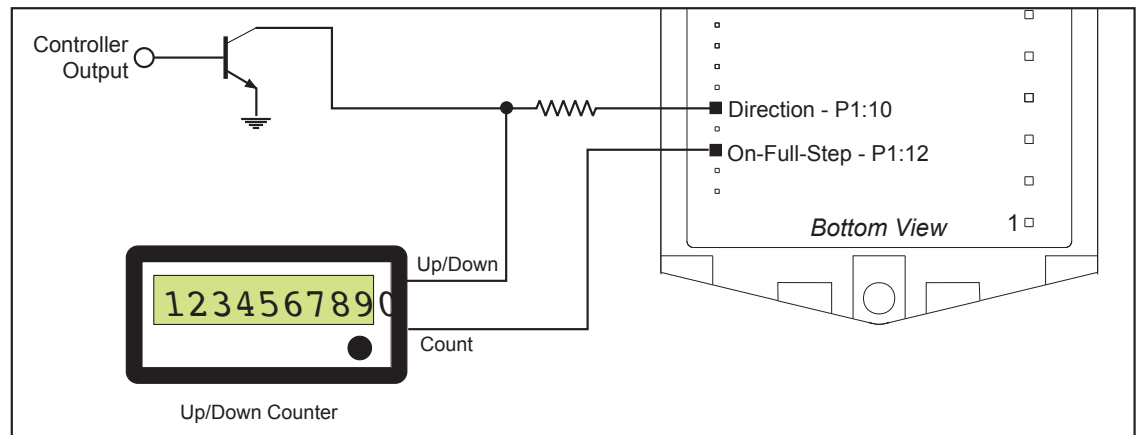

Figure D.3: On-Full-Step Position Counter

WARRANTY

TWENTY-FOUR (24) MONTH LIMITED WARRANTY

Novanta IMS warrants only to the purchaser of the Product from Novanta IMS (the "Customer") that the product purchased from Novanta IMS (the "Product") will be free from defects in materials and workmanship under the normal use and service for which the Product was designed for a period of 24 months from the date of purchase of the Product by the Customer. Customer's exclusive remedy under this Limited Warranty shall be the repair or replacement, at Company's sole option, of the Product, or any part of the Product, determined by Novanta IMS to be defective. In order to exercise its warranty rights, Customer must notify Company in accordance with the instructions described under the heading "Obtaining Warranty Service".

NOTE: MDrive Motion Control electronics are not removable from the motor in the field. The entire unit must be returned to the factory for repair.

This Limited Warranty does not extend to any Product damaged by reason of alteration, accident, abuse, neglect or misuse or improper or inadequate handling; improper or inadequate wiring utilized or installed in connection with the Product; installation, operation or use of the Product not made in strict accordance with the specifications and written instructions provided by Novanta IMS; use of the Product for any purpose other than those for which it was designed; ordinary wear and tear; disasters or Acts of God; unauthorized attachments, alterations or modifications to the Product; the misuse or failure of any item or equipment connected to the Product not supplied by Novanta IMS; improper maintenance or repair of the Product; or any other reason or event not caused by Novanta IMS.

NOVANTA IMS HEREBY DISCLAIMS ALL OTHER WARRANTIES, WHETHER WRITTEN OR ORAL, EXPRESS OR IMPLIED BY LAW OR OTHERWISE, INCLUDING WITHOUT LIMITATION, ANY WARRANTIES OF MERCHANTABILITY OR FITNESS FOR ANY PARTICULAR PURPOSE. CUSTOMER'S SOLE REMEDY FOR ANY DEFECTIVE PRODUCT WILL BE AS STATED ABOVE, AND IN NO EVENT WILL NOVANTA IMS BE LIABLE FOR INCIDENTAL, CONSEQUENTIAL, SPECIAL OR INDIRECT DAMAGES IN CONNECTION WITH THE PRODUCT.

This Limited Warranty shall be void if the Customer fails to comply with all of the terms set forth in this Limited Warranty. This Limited Warranty is the sole warranty offered by Novanta IMS with respect to the Product. Novanta IMS does not assume any other liability in connection with the sale of the Product. No representative of Novanta IMS is authorized to extend this Limited Warranty or to change it in any manner whatsoever. No warranty applies to any party other than the original Customer.

Novanta IMS and its directors, officers, employees, subsidiaries and affiliates shall not be liable for any damages arising from any loss of equipment, loss or distortion of data, loss of time, loss or destruction of software or other property, loss of production or profits, overhead costs, claims of third parties, labor or materials, penalties or liquidated damages or punitive damages, whatsoever, whether based upon breach of warranty, breach of contract, negligence, strict liability or any other legal theory, or other losses or expenses incurred by the Customer or any third party.

OBTAINING WARRANTY SERVICE

If the Product was purchased from an Novanta IMS Distributor, please contact that Distributor to obtain a Returned Material Authorization (RMA). If the Product was purchased directly from Novanta IMS, please contact Customer Service at custservicegroup@novanta.com or 860-295-6102 (Eastern Time Zone).

Customer shall prepay shipping charges for Products returned to Novanta IMS for warranty service and Novanta IMS shall pay for return of Products to Customer by ground transportation. However, Customer shall pay all shipping charges, duties and taxes for Products returned to Novanta IMS from outside the United States.

Novanta IMS

370 N. Main Street
Marlborough, CT 06447
860-295-6102

www.novantaims.com

© Novanta IMS All Rights Reserved. *Product Disclaimer*

and most recent product information at

www.novantaims.com.

REV060123

