

Motion Control MForce MicroDrive and PowerDrive





California Proposition 65 Warning—Lead and Lead Compounds

Advertencia de la Proposición 65 de California—Plomo y compuestos de plomo

Avertissement concernant la Proposition 65 de Californie—Plomb et composés de plomb

⚠ WARNING: This product can expose you to chemicals including lead and lead compounds, which are known to the State of California to cause cancer and birth defects or other reproductive harm. For more information go to: www.P65Warnings.ca.gov.

⚠ ADVERTENCIA: Este producto puede exponerle a químicos incluyendo plomo y compuestos de plomo, que es (son) conocido(s) por el Estado de California como causante(s) de cáncer y defectos de nacimiento u otros daños reproductivos. Para mayor información, visite : www.P65Warnings.ca.gov.

⚠ AVERTISSEMENT: Ce produit peut vous exposer à des agents chimiques, y compris plomb et composés de plomb, identifiés par l'État de Californie comme pouvant causer le cancer et des malformations congénitales ou autres troubles de l'appareil reproducteur. Pour de plus amples informations, prière de consulter: www.P65Warnings.ca.gov.

All trademarks are the property of Novanta IMS and affiliated companies.

Novanta IMS

370 N. Main Street
Marlborough, CT 06447
860-295-6102
www.novantaims.com

Important information

The drive systems described here are products for general use that conform to the state of the art in technology and are designed to prevent any dangers. However, drives and drive controllers that are not specifically designed for safety functions are not approved for applications where the functioning of the drive could endanger persons. The possibility of unexpected or unbraked movements can never be totally excluded without additional safety equipment. For this reason personnel must never be in the danger zone of the drives unless additional suitable safety equipment prevents any personal danger. This applies to operation of the machine during production and also to all service and maintenance work on drives and the machine. The machine design must ensure personal safety. Suitable measures for prevention of property damage are also required.

Qualification of personnel

Only technicians who are familiar with and understand the contents of this manual and the other relevant documentation are authorized to work on and with this drive system. The technicians must be able to detect potential dangers that may be caused by setting parameters, changing parameter values and generally by the operation of mechanical, electrical and electronic equipment.

The technicians must have sufficient technical training, knowledge and experience to recognise and avoid dangers.

The technicians must be familiar with the relevant standards, regulations and safety regulations that must be observed when working on the drive system.

Intended Use

The drive systems described here are products for general use that conform to the state of the art in technology and are designed to prevent any dangers. However, drives and drive controllers that are not specifically designed for safety functions are not approved for applications where the functioning of the drive could endanger persons. The possibility of unexpected or unbraked movements can never be totally excluded without additional safety equipment.

For this reason personnel must never be in the danger zone of the drives unless additional suitable safety equipment prevents any personal danger. This applies to operation of the machine during production and also to all service and maintenance work on drives and the machine. The machine design must ensure personal safety. Suitable measures for prevention of property damage are also required.

In all cases the applicable safety regulations and the specified operating conditions, such as environmental conditions and specified technical data, must be observed.

The drive system must not be commissioned and operated until completion of installation in accordance with the EMC regulations and the specifications in this manual. To prevent personal injury and damage to property damaged drive systems must not be installed or operated.

Changes and modifications of the drive systems are not permitted and if made all no warranty and liability will be accepted.

The drive system must be operated only with the specified wiring and approved accessories. In general, use only original accessories and spare parts.

The drive systems must not be operated in an environment subject to explosion hazard (ex area).

This page intentionally left blank

Table of Contents

Part 1: General Usage

1	Introduction.....	1-1
2	Safety	2-1
3	Power supply selection and connection	3-1
4	Interfacing a Motor	4-1
5	Interfacing RS-422/485 communications	5-1
6	Interfacing CANopen Communications.....	6-1
7	Interfacing I/O	7-1

Part 2: Detailed specifications and connectivity information: MForce

<i>MForce MicroDrive</i>	1	Introduction.....	1-1
	2	Specifications	2-1
	3	Mounting and connection recommendations.....	3-1
	4	Connection and interface	4-1
<i>MForce PowerDrive</i>	1	Introduction.....	1-1
	2	Specifications	2-1
	3	Mounting and connection recommendations.....	3-1
	4	Connection and interface	4-1

Page intentionally left blank

Motion Control MForce

MicroDrive and PowerDrive

Part 1: General Usage

1. Introduction
2. Safety
3. Interfacing DC power
4. Interfacing a Motor
5. Interfacing serial communications
6. Interfacing CANopen communications
7. Interfacing I/O

This page intentionally left blank

Table of Contents

Important information..... 3
 Qualification of personnel 3
 Intended Use 3

1 Introduction..... 1-1

1.1 MForce versions 1-1
 1.3 Documentation reference 1-2
 1.4 Product software 1-2
 1.4.1 Communications converter drivers 1-2
 1.4.2 Novanta IMS Terminal 1-2

2 Safety..... 1

2.1 Qualification of personnel..... 1
 2.2 Intended Use 1
 2.3 Hazard Categories 2
 2.4 General safety instructions..... 2

3 Interfacing DC power 3-1

3.1 Applicability 3-2
 3.2 Selecting a power supply (+V) 3-2
 3.2.1 Power supply — motor relationship 3-2
 3.2.2 Power supply — driver relationship 3-2
 3.2.3 Regulated vs unregulated..... 3-3
 3.3 Power supply cabling recommendations..... 3-3
 3.3.1 DC Cabling Under 50’ (15.24 m) 3-4
 3.3.2 AC power to full wave bridge 3-4
 3.3.3 AC power DC supply 3-5
 3.3.4 Recommended wire gauges 3-5
 3.4 Switching DC power (DPM75 accessory) 3-6

4 Interfacing a stepper motor 4-1

4.1 Selecting a motor 4-1
 4.1.1 Winding inductance 4-1
 4.2 Recommended motor cable configurations..... 4-3
 4.2.1 Motor cabling under 50’ (15.0 m)..... 4-4
 4.2.2 Motor cabling over 50’ (15.0 m)..... 4-4
 4.2.3 Recommended motor cable wire gauges 4-5
 4.3 Wiring configurations for various motor types 4-5
 4.3.1 8-lead motors..... 4-5
 4.3.2 6-lead motors..... 4-6
 4.3.3 4-lead motors..... 4-7

5 Interfacing serial communications 5-1

5.1 Applicability 5-1
 5.2 USB to RS-422/485 isolated communications converter
 cables 5-1
 5.2.2 Driver installation procedure 5-1
 5.3 Interfacing single mode communications 5-3
 5.3.1 Full duplex (RS-422)..... 5-3
 5.3.2 Half duplex (RS-485) 5-4
 5.4 interfacing party mode communications..... 5-5

5.4.1	Mutli-drop communications using Novanta IMS MD-CC402-001	5-5
5.4.2	Mutli-drop communications connection	5-7
5.4.3	System power connection for a multi-drop system	5-8
5.4.4	Software configuration	5-9
6	Interfacing CANopen communications	6-1
6.1	Features	6-1
6.2	Interfacing the can bus	6-1
6.2.1	CAN bus connections	6-1
6.2.2	Recommended CANopen dongle	6-2
6.3	CANopen Tester quick start	6-3
6.3.1	Installation.....	6-3
6.3.2	Getting Started with CANopen Tester	6-3
7	Interfacing I/O	7-1
7.1	I/O configurations	7-2
7.1.1	I/O States.....	7-2
7.2	General purpose I/O.....	7-3
7.2.1	General purpose input functions.....	7-3
7.2.2	General purpose output functions.....	7-3
7.2.2	Interfacing sinking inputs	7-4
7.2.3	Interfacing sinking outputs.....	7-5
7.2.4	Interfacing sourcing inputs.....	7-6
7.2.5	Interfacing sourcing outputs.....	7-7
7.2.5	Mixed I/O Example	7-8
7.2.5	Mixed I/O Example (expanded)	7-8
7.2.6	Interfacing to a bank of I/O points.....	7-9
7.3	Dedicated I/O	7-11
7.3.1	Capture input/trip output	7-11
7.4	Analog input	7-12

List of Figures

Figure 3.1	DC power supply cabling under 50' (15.24 m)	3-4
Figure 3.2	50' (15.2 m) or greater, AC power to full wave bridge.....	3-4
Figure 3.3	50' (15.2 m) or greater, AC power to DC supply	3-5
Figure 3.4	DPM75 basic wiring and connection	3-6
Figure 4.1	Motor winding inductance.....	4-2
Figure 4.2	Motor cabling under 50' (15.0 m)	4-4
Figure 4.3	Motor cabling over 50' (15.0 m).....	4-4
Figure 4.4	8-lead motor series connection	4-5
Figure 4.5	8-lead parallel connection	4-6
Figure 4.6	6-lead half coil configuration.....	4-6
Figure 4.7	6-lead motor full coil configuration.....	4-7
Figure 4.8	4-lead motor connection.....	4-7
Figure 5.2	Full duplex RS-422 connection.	5-3
Figure 5.3	Half duplex RS-485 connection.....	5-4
Figure 5.4	Multi-drop communications using the PD10-1434-FL3	5-6
Figure 5.5	Wiring a second PD10-1434-FL3 into the 10-pin wire crimp connector.	5-6
Figure 5.6	Interface for party-mode operation.....	5-7
Figure 5.7	Power interface for eliminating communications ground loops.....	5-8
Figure 6.1	Interfacing the CAN bus	6-1
Figure 6.2	MD-CC500-000 USB to CANopen commissioning cable.....	6-2
Figure 6.3	CANopen Tester.....	6-4
Figure 7.1	Sinking input equivalent circuit and interface examples.....	7-4
Figure 7.2	Sinking output equivalent circuit and interface examples.....	7-5
Figure 7.3	Sourcing input equivalent circuit and interface examples	7-6
Figure 7.4	Sourcing output equivalent circuit and interface examples ...	7-7
Figure 7.5	Mixed inputs and outputs, standard MForce.	7-8
Figure 7.6	Mixed inputs and outputs, expanded MForce.	7-8
Figure 7.7	TTL interface to I/O banks as a group for BCD program control.....	7-9
Figure 7.7	Output interface to I/O banks as a group for BCD process control.....	7-10
Figure 7.8	Input equivalent circuit, capture/trip I/O.....	7-11
Figure 7.9	Analog input interface.....	7-12

List of Tables

Table 3.2	Power supply cable AWG recommendations	3-5
Table 4.1	Motor cable AWG recommendations	4-5
Table 7.1	MForce I/O configurations	7-2
Table 7.2	General purpose input functions	7-3
Table 7.3	General purpose output functions	7-3

Page intentionally left blank

1 Introduction

The ultra compact Motion Control MForce offers system designers a low cost, high performance microstepping driver integrated with an intelligent, programmable motion controller.

Standard features include four +5 to +24 volt general purpose I/O lines, one 10 bit analog input, 0 to 5MHz step clock rate, 20 microstep resolutions up to 51,200 steps per revolution, and full featured easy-to-program instruction set.

Expanded features in the Plus2 version include up to eight +5 to +24 volt general purpose I/O lines and the capability of electronic gearing by following a rotary or linear axis at an electronically controlled ratio, or an output clock can be generated fixed to the internal step clock.

Motion Control MForce Plus² are available with optional closed loop control. This increases functionality by adding stall detection, position maintenance and find index mark. The closed loop configuration offers an expanded choice of line counts and resolutions by interfacing to a remotely mounted user-supplied external encoder.

Motion Control MForce MicroDrives communicate over RS-422/485 which allows for point-to-point or multiple unit configurations utilizing one communication port. Addressing and hardware support up to 62 uniquely addressed units communicating over a single line. Baud rate is selectable from 4.8 to 115.2kbps.

Optional communication protocols include CANopen. The CAN bus is 2.0B active (11 and/or 29 bit) and is capable of all standard frequencies from 10kHz to 1MHz. CANopen features include node guarding, heartbeat producer, SDOs and PDOs. Highlights include variable PDO mapping and extended node identifier.*

The Motion Control MForce is a compact, powerful and inexpensive solution that will reduce system cost, design and assembly time for a large range of applications.

1.1 MForce versions

The MForce is available in the following power ranges:

+12 to +48 VDC

- MForce MicroDrive

+12 to +75 VDC

- MForce PowerDrive

1.3 Documentation reference

The following user's manuals are available for the MForce:

- Product hardware manual, describes the technical data and installation of the product.
- Product software manual, describes the configuration and programming of the product.
- Quick Reference, describes the basic wiring, connection and use of this product. The quick reference is shipped in printed form with the product.

This documentation is also available for download from the Novanta IMS web site at www.novantaims.com

1.4 Product software

1.4.1 Communications converter drivers

If using the our communications converter, drivers are required, these drivers are available for download from the web site at <https://novantaims.com/dloads/>.

1.4.2 Novanta IMS Terminal

The Motion Control MForce can be configured and programmed using any standard ANSI terminal emulator and ASCII text editor.

The recommended tool is the Novanta IMS Terminal integrated terminal and program editor. Novanta IMS Terminal features color-coded editor, multiple-function keys and is preconfigured to operate using the MForce default settings

Installation and usages instructions are to be found in MCode software manual.

This software may be downloaded from <https://novantaims.com/dloads/>

2 Safety

2.1 Qualification of personnel

Only technicians who are familiar with and understand the contents of this manual and the other relevant documentation are authorized to work on and with this drive system. The technicians must be able to detect potential dangers that may be caused by setting parameters, changing parameter values and generally by the operation of mechanical, electrical and electronic equipment.

The technicians must have sufficient technical training, knowledge and experience to recognise and avoid dangers.

The technicians must be familiar with the relevant standards, regulations and safety regulations that must be observed when working on the drive system.

2.2 Intended Use

The drive systems described here are products for general use that conform to the state of the art in technology and are designed to prevent any dangers. However, drives and drive controllers that are not specifically designed for safety functions are not approved for applications where the functioning of the drive could endanger persons. The possibility of unexpected or unbraked movements can never be totally excluded without additional safety equipment.

For this reason personnel must never be in the danger zone of the drives unless additional suitable safety equipment prevents any personal danger. This applies to operation of the machine during production and also to all service and maintenance work on drives and the machine. The machine design must ensure personal safety. Suitable measures for prevention of property damage are also required.

In all cases the applicable safety regulations and the specified operating conditions, such as environmental conditions and specified technical data, must be observed.

The drive system must not be commissioned and operated until completion of installation in accordance with the EMC regulations and the specifications in this manual. To prevent personal injury and damage to property damaged drive systems must not be installed or operated.

Changes and modifications of the drive systems are not permitted and if made no warranty and liability will be accepted.

The drive system must be operated only with the specified wiring and approved accessories. In general, use only original accessories and spare parts.

The drive systems must not be operated in an environment subject to explosion hazard (ex area).

2.3 Hazard Categories

Safety notes and general information are indicated by hazard messages in the manual. In addition there are symbols and instructions affixed to the product that warn of possible hazards and help to operate the product safely.

Depending on the seriousness of the hazard, the messages are divided into three hazard categories.

DANGER

DANGER indicates an imminently hazardous situation, which, if not avoided, **will result** in death, serious injury, or equipment damage.

WARNING

WARNING indicates a potentially hazardous situation, which, if not avoided, **can result** in death, serious injury, or equipment damage.

CAUTION

CAUTION indicates a potentially hazardous situation, which, if not avoided, **can result** in injury or equipment damage.

2.4 General safety instructions

DANGER

EXPOSED SIGNALS

Hazardous voltage levels may be present if using an open frame power supply to power the product.

Failure to follow these instructions will result in death or serious injury.

 **WARNING****LOSS OF CONTROL**

- Observe the accident prevention regulations. (For USA see also NEMA ICS1.1 and NEMA ICS7.1)
- The system manufacturer must take the potential error possibilities of the signals and the critical functions into account to ensure a safe status during and after errors. Some examples are: emergency stop, final position limitation, power failure and restart.
- The assessment of error possibilities must also include unexpected delays and the failure of signals or functions.
- Suitable redundant control paths must be in place for dangerous functions.
- Check that measures taken are effective.

Failure to follow these instructions can result in death or serious injury.

 **CAUTION****HOT PLUGGING!**

Do not connect or disconnect power, logic, or communications while the device is in a powered state.

Remove DC power by powering down at the AC side of the DC power supply.

Failure to follow these instructions can result in equipment damage.

This page has been intentionally left blank.

3 Interfacing DC power

⚠ DANGER

EXPOSED SIGNALS

Hazardous voltage levels may be present if using an open frame power supply to power the product.

Failure to follow these instructions will result in death or serious injury.

⚠ CAUTION

MAXIMUM VOLTAGE INPUT

Do not exceed the maximum rated voltage of the device! Motor Back EMF, power supply ripple and high line must be taken into account when selecting a power supply voltage level.

Failure to follow these instructions may result in damage to system components!

⚠ CAUTION

GENERAL POWER SUPPLY PRACTICE

Do not connect or disconnect the power supply while power is applied.

Disconnect the AC side to power down the DC supply.

For battery operated systems connect a “transient suppressor” across the switch to prevent arcs and high-voltage spikes.

Failure to follow these instructions may result in damage to system components!

⚠ CAUTION

HOT PLUGGING!

Do not connect or disconnect power, logic, or communications while the device is in a powered state.

Remove DC power by powering down at the AC side of the DC power supply.

Failure to follow these instructions may result in damage to system components!



Detailed specifications, voltage limits, current requirements and connectivity information are located in the product detail section corresponding to the MForce model you purchased.

3.1 Applicability

This section applies to all Motion Control MForce products with a DC power input.

3.2 Selecting a power supply (+V)

Proper selection of a power supply to be used in a motion system is as important as selecting the drive itself. When choosing a power supply for a stepping motor driver, there are several performance issues that must be addressed. An undersized power supply can lead to poor performance and possibly even damage to your drive.

3.2.1 Power supply — motor relationship

Motor windings can basically be viewed as inductors. Winding resistance(R) and inductance(L) result in an L/R time constant that resists the change in current. To effectively manipulate the rate of charge, the voltage applied is increased. When traveling at high speeds, there is less time between steps to reach current. The point where the rate of commutation does not allow the driver to reach full current is referred to as voltage mode. Ideally you want to be in current mode, which is when the drive is achieving the desired current between steps. Simply stated, a higher voltage will decrease the time it takes to charge the coil and, therefore, will allow for higher torque at higher speeds.

Another characteristic of all motors is back EMF. Back EMF is a source of current that can push the output of a power supply beyond the maximum operating voltage of the driver. As a result, damage to the stepper driver could occur over a period of time. This is especially prevalent with overhauling loads.

3.2.2 Power supply — driver relationship

The MForce is very current efficient as far as the power supply is concerned. Once the motor has charged one or both windings of the motor, all the power supply has to do is replace losses in the system. The charged winding acts as an energy storage in that the current will recirculate within the bridge and in and out of each phase reservoir. This results in a less than expected current draw on the power supply.

Stepping motor drivers are designed with the intent that a user's power supply output will ramp up to greater than or equal to the minimum operating voltage of the drive. The initial current surge is substantial and could damage the driver if the supply is undersized. The output of an undersized power supply could fall below the operating range of the driver upon a current surge. This could cause the power supply to start oscillating in and out of the voltage range of the driver and result in damage to either the supply, the driver, or both.

There are two types of supplies commonly used, regulated and unregulated, both of which can be switching or linear. Each have advantages and disadvantages.

3.2.3 Regulated vs unregulated

An unregulated linear supply is less expensive and more resilient to current surges, however, the voltage decreases with increasing current draw. This may cause problems if the voltage drops below the working range of the drive.

Fluctuations in line voltage are also a point of concern. These fluctuations may cause the unregulated linear supply to be above or below the anticipated or acceptable voltage.

A regulated supply maintains a stable output voltage, which is good for high speed performance. These supplies are also not affected by line fluctuations, however, they are more expensive. Depending on the current regulation, a regulated supply may crowbar or current clamp and lead to an oscillation that, as previously stated, can cause damage to the driver and/or supply. Back EMF can cause problems for regulated supplies as well. The current regeneration may be too large for the regulated supply to absorb. This could lead to an over voltage condition which could damage the output circuitry of the MForce.

Non Novanta IMS switching power supplies and regulated linear supplies with over current protection are not recommended because of their inability to handle the surge currents inherent in stepping motor systems.

See the product detail section of this document for specific powersupplyvoltageand current requirements and recommended power supplies.

3.3 Power supply cabling recommendations

 CAUTION
<p>EMI and RFI</p> <p>These recommendations will provide optimal protection against EMI and RFI. The actual cable type, wire gauge, shield type and filtering devices used are dependent on the customer’s application and system.</p> <p>The length of the DC power supply cable to an MForce should not exceed 50 feet (15.2 m).</p> <p>Always use Shielded/Twisted Pairs for the MForce DC Supply Cable and the AC Supply Cable.</p> <p>Failure to follow these instructions may result in damage to system components!</p>

Cable length, wire gauge and power conditioning devices play a major role in the performance of your MForce.

Figure 3.1 illustrates the recommended cable configuration for DC power supply cabling under 50 feet (15.2 m) long. If cabling of 50 feet (15.2 m) or longer is required, the additional length may be gained by adding an AC power supply cable (see Figures 3.2 and 3.3).

Correct AWG wire size is determined by the current requirement plus cable length. Please see Table 3.1.

3.3.1 DC Cabling Under 50' (15.24 m)

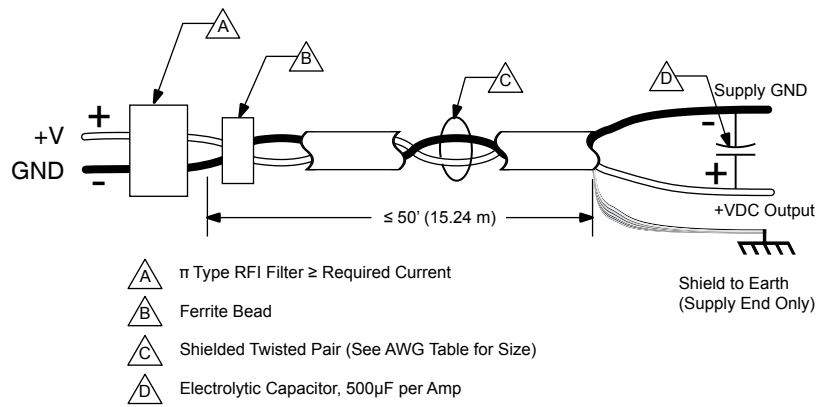

Figure 3.1 DC power supply cabling under 50' (15.24 m)

3.3.2 AC power to full wave bridge

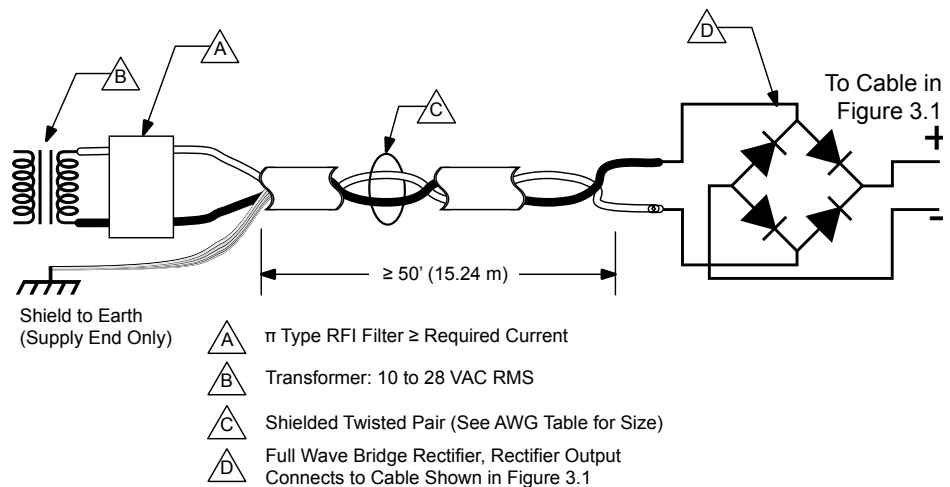

Figure 3.2 50' (15.2 m) or greater, AC power to full wave bridge

3.3.3 AC power DC supply

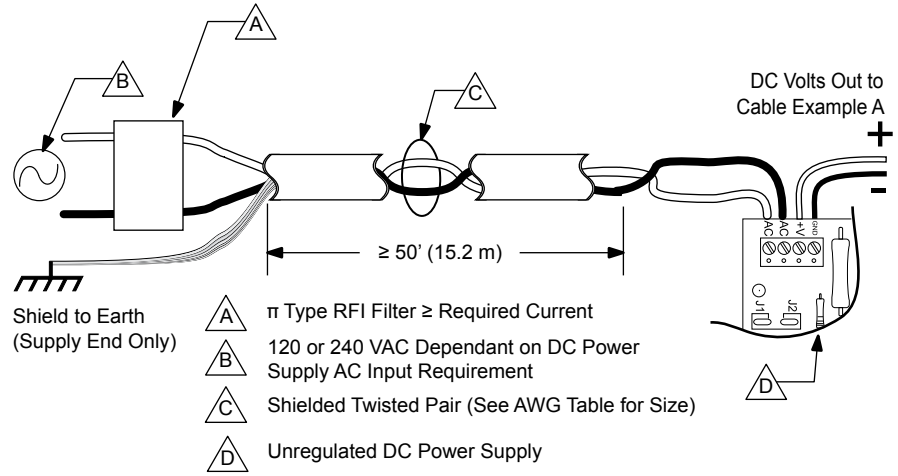

Figure 3.3 50' (15.2 m) or greater, AC power to DC supply

3.3.4 Recommended wire gauges

For cable lengths exceeding 50' (15.2 m), use the cable configurations shown in Figures 3.2 and 3.3.

Cable Length: Feet (meters)	10 (3.0)	25 (7.6)	50 (15.2)	75 (22.9)	100 (30.5)
Amps Peak	Minimum AWG				
1 Amp Peak	20	20	18	18	18
2 Amps Peak	20	18	16	14	14
3 Amps Peak	18	16	14	12	12
4 Amps Peak	18	16	14	12	12

Table 3.2 Power supply cable AWG recommendations



Detailed specifications, voltage limits and connectivity information are located in the product detail section corresponding to the MForce model you purchased.

3.4 Switching DC power (DPM75 accessory)

⚠ CAUTION
<p>HOT PLUGGING!</p> <p>Do not connect or disconnect power, logic, or communications while the device is in a powered state without additional protection.</p> <p>Remove DC power by powering down at the AC side of the DC power supply.</p> <p>Failure to follow these instructions may result in damage to system components!</p>

The function of the DPM75 Drive Protection Module is to limit the surge current and voltage to a safe level when DC input power is switched on and off to a motor drive. This provides the added protection necessary for reliable motor drive operation when switching the DC power, instead of the recommended AC power to the DC power supply. The device is designed to protect the motor drive when operating under all load conditions. This device does not protect the motor drive from wiring the power incorrectly.

The unit is capable of being used with 48, 60, and 75 volt rated motor drives. An external jumper selection is available so the user can match the circuit to their particular application. The DPM75 is capable of a steady state operating current of 4 amps.

The DPM75 can be used for any frame size motor drive, when properly configured. It can also be used for more than one unit provided the current and voltage do not exceed the DPM75's ratings. The maximum DPM75 ratings are 75 volts and 4 amps.

Power requirements and wiring details are available in the product detail section pertaining to the product purchased.

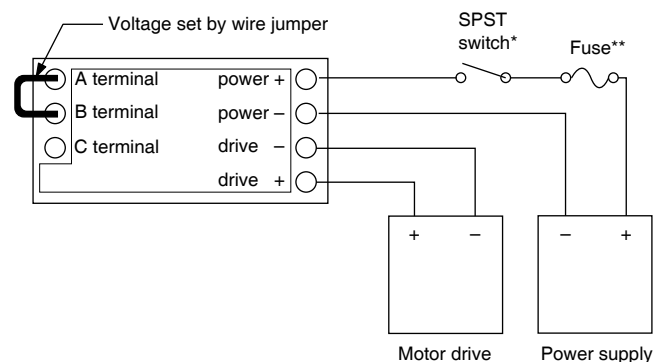

* Do not switch negative side of supply

**Fuse = 6.3 Amp slow blow (recommended: Bussman S505-6.3A or Littelfuse 215006.3). The fuse is optional.

Figure 3.4 DPM75 basic wiring and connection

4 Interfacing a stepper motor

DANGER

EXPOSED SIGNALS

Hazardous voltage levels may be present if using an open frame power supply to power the product.

Failure to follow these instructions will result in death or serious injury.

CAUTION

MOTOR TEMPERATURE

Although stepping motors will run hot when configured correctly, damage may occur to a motor if a higher than specified current is used. In most cases, the specified motor currents are maximum values and should not be exceeded!

Failure to follow these instructions may result in damage to system components!

4.1 Selecting a motor

The MForce is a bipolar driver which works equally well with both bipolar and unipolar motors (i.e. 8 and 4 lead motors, and 6 lead center tapped motors).

To maintain a given set motor current, the MForce chops the voltage using a variable chopping frequency and a varying duty cycle. Duty cycles that exceed 50% can cause unstable chopping. This characteristic is directly related to the motor's winding inductance. In order to avoid this situation, it is necessary to choose a motor with a low winding inductance. The lower the winding inductance, the higher the step rate possible.

4.1.1 Winding inductance

Since the MForce is a constant current source, it is not necessary to use a motor that is rated at the same voltage as the supply voltage. What is important is that the MForce is set to the motor's rated current.

The higher the voltage used the faster the current can flow through the motor windings. This in turn means a higher step rate, or motor speed. Care should be taken not to exceed the maximum voltage of the driver. Therefore, in choosing a motor for a system design, the best performance for a specified torque is a motor with the lowest possible winding inductance used in conjunction with highest possible driver voltage.

The winding inductance will determine the motor type and wiring configuration best suited for your system. While the equation used to size a motor for your system is quite simple, several factors fall into play at this point.

The winding inductance of a motor is rated in milliHenrys (mH) per Phase. The amount of inductance will depend on the wiring configuration of the motor.

The per phase winding inductance specified may be different than the per phase inductance seen by your MForce depends on the wiring configuration used. Your calculations must allow for the actual inductance that the driver will see based upon the wiring configuration.

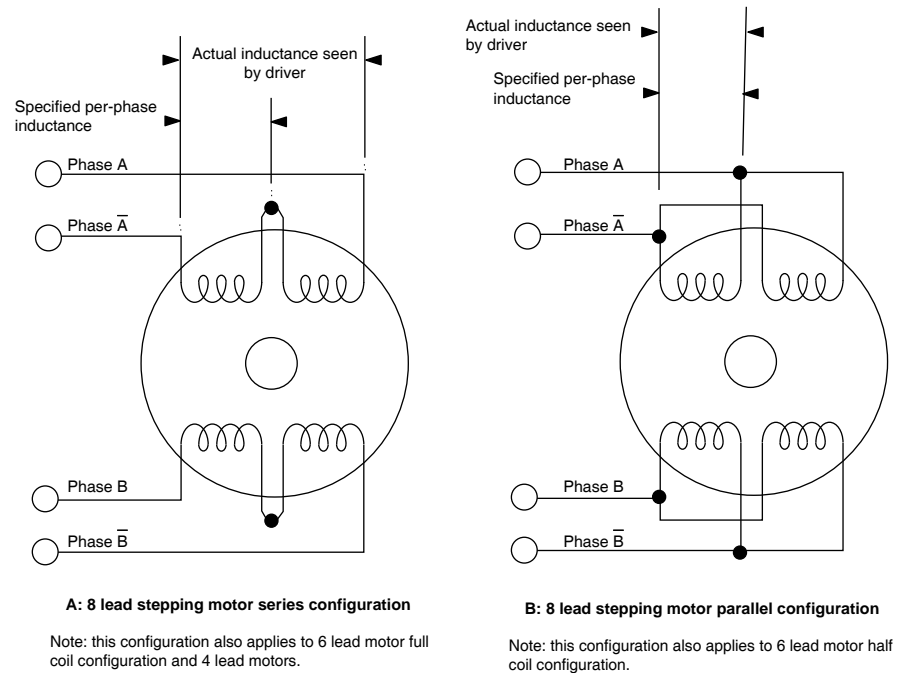

Figure 4.1 Motor winding inductance

Figure 4.1A shows a stepper motor in a series configuration. In this configuration, the per phase inductance will be 4 times that specified. For example: a stepping motor has a specified per phase inductance of 1.47mH. In this configuration the driver will see 5.88 mH per phase.

Figure 4.1B shows an 8 lead motor wired in parallel. Using this configuration the per phase inductance seen by the driver will be as specified below.

Using the following equation we will show an example of sizing a motor used with an unregulated power supply with a minimum voltage (+V) of 24 VDC:

$$.2 \times \text{min power supply voltage (VDC)} = \text{min. inductance (mH/phase)}$$

$$.2 \times 24 = 4.8 \text{ mH}$$

The recommended per phase winding inductance we can use is 4.8 mH.

4.2 Recommended motor cable configurations

 CAUTION
EMI AND RFI These recommendations will provide optimal protection against EMI and RFI. The actual cable type, wire gauge, shield type and filtering devices used are dependent on the customer's application and system. Always use Shielded/Twisted Pairs for the Motor Cable Failure to follow these instructions may result in damage to system components!

Cable length, wire gauge and power conditioning devices play a major role in the performance of the system.

NOTE: The length of the cable between the MForce and the motor should not exceed 50' (15.0 m).

4.2.1 demonstrates the recommended cable configuration for the MForce to motor cabling under 50' (15.0 m). If cabling of 50' (15.0 m) or longer is required, the additional length can be gained with the cable configuration in 4.2.2.

Correct AWG wire size is determined by the current requirement plus cable length. Please see the motor cable AWG table at the end of this subsection.

4.2.1 Motor cabling under 50' (15.0 m)

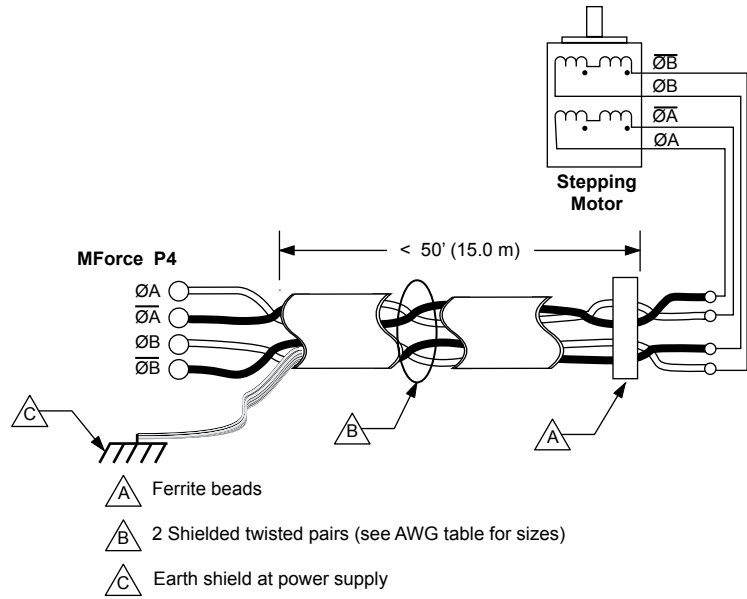

Figure 4.2 Motor cabling under 50' (15.0 m)

4.2.2 Motor cabling over 50' (15.0 m)

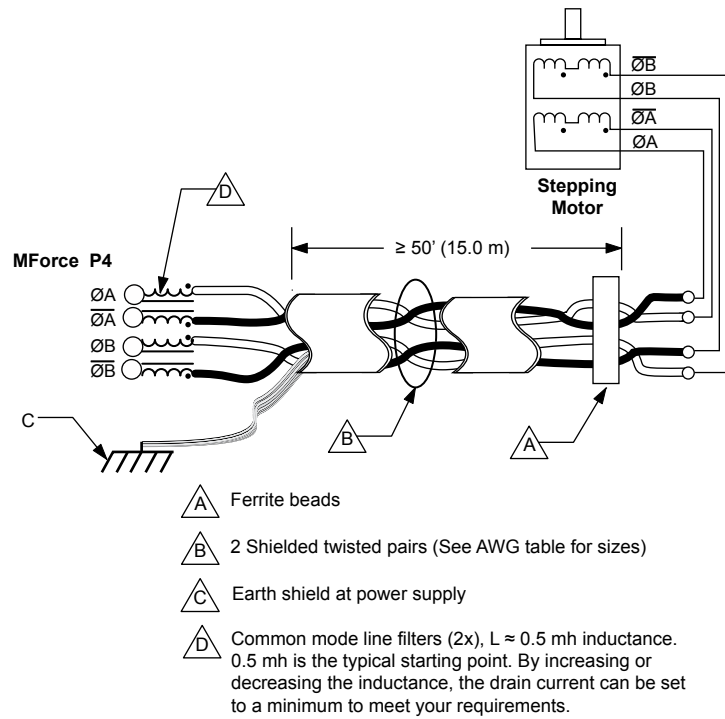

Figure 4.3 Motor cabling over 50' (15.0 m)

4.2.3 Recommended motor cable wire gauges

For cable lengths exceeding 50' (15.0 m), use the cable configurations shown in 4.2.2

Cable Length: Feet (meters)	10 (3.0)	25 (7.6)	50 (15.2)	75 (22.9)	100 (30.5)
Amps Peak	Minimum AWG				
1 Amp Peak	20	20	18	18	18
2 Amps Peak	20	18	16	14	14
3 Amps Peak	18	16	14	12	12
4 Amps Peak	18	16	14	12	12

Table 4.1 Motor cable AWG recommendations

4.3 Wiring configurations for various motor types

⚠ CAUTION

CORRECT WIRING

Ensure that the motor phase leads are connected to the corresponding connector pins to avoid Phase A to Phase B crossover.

Failure to follow these instructions may result in damage to system components!

4.3.1 8-lead motors

8 lead motors offer a high degree of flexibility to the system designer in that they may be connected in series or parallel, thus satisfying a wide range of applications.

Series connection

A series motor configuration would typically be used in applications where a higher torque at lower speeds is required. Because this configuration has the most inductance, the performance will start to degrade at higher speeds. Use the per phase (or unipolar) current rating as the peak output current, or multiply the bipolar current rating by 1.4 to determine the peak output current.

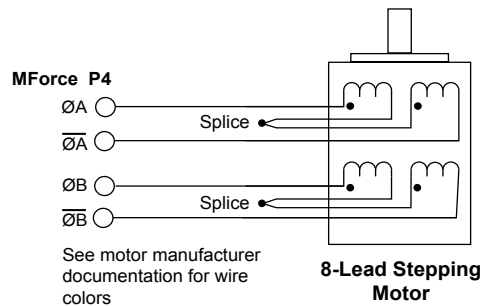

Figure 4.4 8-lead motor series connection

Parallel connection

An 8 lead motor in a parallel configuration offers a more stable, but lower torque at lower speeds. But because of the lower inductance, there will be higher torque at higher speeds. Multiply the per phase (or unipolar) current rating by 1.96, or the bipolar current rating by 1.4, to determine the peak output current.

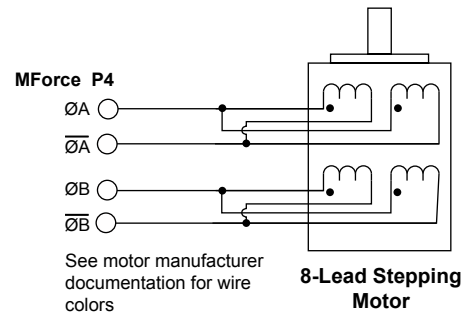

Figure 4.5 8-lead parallel connection

4.3.2 6-lead motors

Like 8 lead stepping motors, 6 lead motors have two configurations available for high speed or high torque operation. The higher speed configuration, or half coil, is so described because it uses one half of the motor's inductor windings. The higher torque configuration, or full coil, uses the full windings of the phases.

Half coil configuration

As previously stated, the half coil configuration uses 50% of the motor phase windings. This gives lower inductance, hence, lower torque output. Like the parallel connection of 8 lead motor, the torque output will be more stable at higher speeds. This configuration is also referred to as half copper. In setting the driver output current multiply the specified per phase (or unipolar) current rating by 1.4 to determine the peak output current.

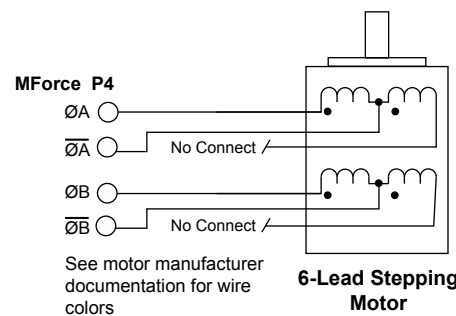

Figure 4.6 6-lead half coil configuration

Full coil configuration

The full coil configuration on a six lead motor should be used in applications where higher torque at lower speeds is desired. This configuration is also referred to as full copper. Use the per phase (or unipolar) current rating as the peak output current.

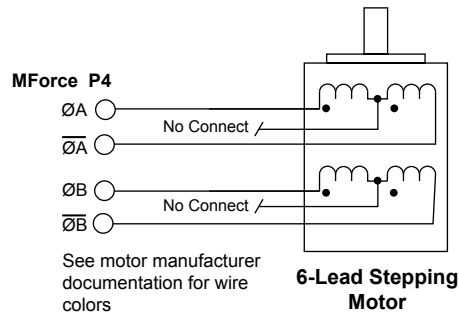

Figure 4.7 6-lead motor full coil configuration

7.3.3 4-lead motors

4 lead motors are the least flexible but easiest to wire. Speed and torque will depend on winding inductance. In setting the driver output current, multiply the specified phase current by 1.4 to determine the peak output current.

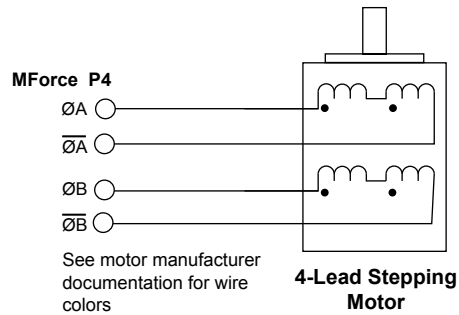

Figure 4.8 4-lead motor connection

Page intentionally left blank

5 Interfacing serial communications

The MForce communicates to the host using the RS-422/485 protocol. Communications may be configured as either half duplex (RS-485) or full duplex (RS-422) using the EM (Echo Mode) Instruction. RS-422/485 may be used in two ways: either to communicate to a single MForce, or to address up to 62 individually named nodes in a multidrop system.

5.1 Applicability

This section applies to all Motion Control MForce models with an RS-422/485 communications interface.

5.2 USB to RS-422/485 isolated communications converter cables

To simplify the wiring and connection process we offer an electrically isolated USB to RS-422/485 communications cables for the MForce. These convenient 12.0' (3.6m) accessory cables connect a PC's USB port to the MForce P2 connector. An in-line RS-422/485 converter enables parameter setting to a single MForce. Cable purchase recommended with first order.

There are two communications converter cables available depending on the connector type:

USB to 10-pin wire crimp.....Part No. MD-CC402-001

USB to 10-pin IDC.....Part No. MD-CC400-001

5.2.2 Driver installation procedure

These Installation procedures are written for Microsoft Windows XP Service Pack 2. Users with earlier versions of Windows please see the alternate installation instructions at the web site (www.novantaims.com).

The installation of the MD-CC40x-000 requires the installation of two sets of drivers:

- Drivers for the USB to RS-422 Converter Hardware.
- Drivers for the Virtual Communications Port (VCP) used to communicate to your Product.

Therefore the Hardware Update wizard will run twice during the installation process.

The full installation procedure will be a two-part process: Installing the Cable/VCP drivers and Determining the Virtual COM Port used.

-
- Installing the Cable/VCP Drivers*
- 1) Download the MD-CC40x-001 communications converter drivers from <https://novantaims.com/downloads/>. Extract to a folder on your hard drive.
 - 2) Plug the USB converter cable into the USB port of the MD-CC40x-001.
 - 3) Plug the other end of the USB cable into an open USB port on your PC.
 - 4) Your PC will recognize the new hardware and open the Hardware Update dialog.
 - 5) Select “No, not this time” on the radio buttons in answer to the query “Can Windows Connect to Windows Update to search for software?” Click “Next”.
 - 6) Select “Install from a list or specific location (Advanced)” on the radio buttons in answer to the query “What do you want the wizard to do?” Click “Next”.
 - Select “Search for the best driver in these locations.”
 - Check “Include this location in the search.”
 - Browse to the download location on your hard drive.
 - 7) Click Next.
 - 8) The drivers will begin to copy.
 - 9) On the Dialog for Windows Logo Compatibility Testing, click “Continue Anyway”.
 - 10) The Driver Installation will proceed. When the Completing the Found New Hardware Wizard dialog appears, Click “Finish”.
 - 11) Upon finish, the Welcome to the Hardware Update Wizard will re-appear to guide you through the second part of the install process. Repeat steps 1 through 9 above to complete the cable installation.
 - 12) Your Novanta IMS MD-CC40x-001 is now ready to use.

Determining the Virtual COM Port (VCP)

The MD-CC40x-000 uses a Virtual COM Port to communicate through the USB port to the MForce. A VCP is a software driven serial port which emulates a hardware port in Windows.

The drivers for the MD-CC40x-000 will automatically assign a VCP to the device during installation. The VCP port number will be needed when Novanta IMS Terminal is set up in order that Novanta IMS Terminal will know where to find and communicate with your Novanta IMS Product.

To locate the Virtual COM Port.

- 1) Right-Click the “My Computer” Icon and select “Properties”.
- 2) Browse to the Hardware Tab, Click the Button labeled “Device Manager”.
- 3) Look in the heading “Ports (COM & LPT)” Novanta IMS USB to RS-422 Converter Cable (COMx) will be listed). The COM # will be the Virtual COM Port connected. You will enter this number into your Novanta IMS Terminal Configuration.

5.3 Interfacing single mode communications

⚠ CAUTION

HOT PLUGGING!

Do not connect or disconnect communications while the device is in a powered state.

Failure to follow these instructions may result in damage to system components!

5.3.1 Full duplex (RS-422)

To interface the MForce using RS-422 protocol you will need one of the following:

- A PC equipped with RS-422 Interface.
- A PC RS-232 to RS-422/485 converter.
- MD-CC402-001 or equivalent communications converter.

Use the following diagram to connect RS-422 communications to the MForce (not required if using the Novanta IMS cables)

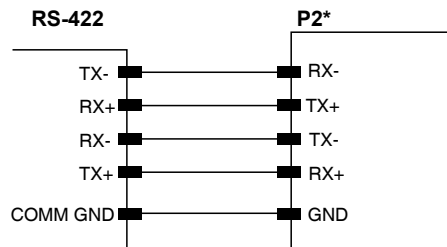

* see the section in Part 2 applicable to the model you purchased for pinout information

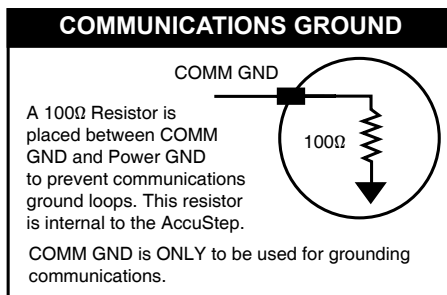
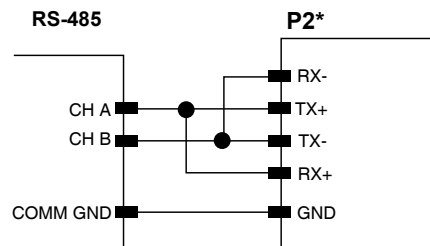

Figure 5.2 Full duplex RS-422 connection.

5.3.2 Half duplex (RS-485)

The MForce can be operated in a two wire RS-485 communication bus. Before connecting the two wire RS-485, download your program and setup instructions using the standard four wire RS-422 Communications Cable. If a program is not being used, download and save any setup parameters. To ensure the MForce responds only to commands specifically meant for it, set the unit in party mode

The Echo Mode command (EM) must be set to the value of 1 (EM=1). This will set the MForce communication into “half duplex” mode. Connect the driver in the two wire RS-485 configuration. The following diagram illustrates how to connect the four wire RS-485 to operate as a two wire system.



* see the section in Part 2 applicable to the model you purchased for pinout information

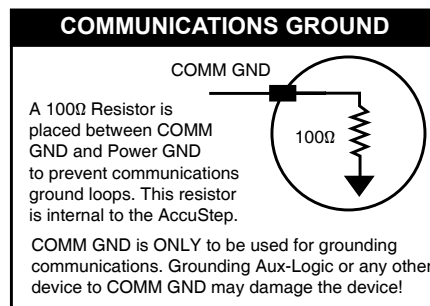





Figure 5.3 Half duplex RS-485 connection.

5.4 interfacing party mode communications

 CAUTION
HOT PLUGGING! Do not connect or disconnect communications while the device is in a powered state. Failure to follow these instructions may result in damage to system components!

 CAUTION
COMMUNICATIONS GROUND LOOPS To avoid ground loops in the system only connect communications ground to the first MForce in the system. Do not connect communications ground on subsequent MForces. Failure to follow these instructions may result in damage to system components!

 CAUTION
SHIELDED CABLES Do not use the Novanta IMS MD-CC400-001 communications converter cable for multi-drop systems. Ribbon cables are not recommended for use in multi-drop communications systems due to the lack of shielded cabling. Failure to follow these instructions may result in damage to system components!



DEVICE NAME

Each unit in a party mode system must have a unique identifier, or device name. Each unit **MUST** be connected and communicated with in single mode communications and given a name using the DN command

Please reference the MCode Programming and Software manual, Appendix H for more information.

5.4.1 Multi-drop communications using Novanta IMS MD-CC402-001

Required:

- MD-CC402-001 communications converter cable
- PD10-1434-FL3 prototype development cable(s)

Used in conjunction with the MD-CC402-001 communications converter cable to facilitate multi-drop RS-422/485 communications.

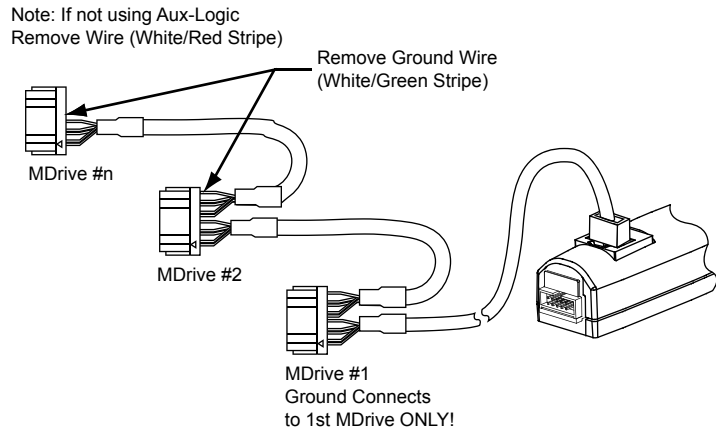
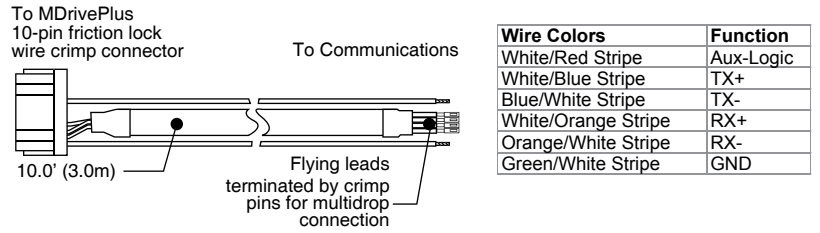

Figure 5.4 Multi-drop communications using the PD10-1434-FL3

Procedure

- 1) Remove ground wire (unless this is the first system MForce, green/white stripe)
- 2) Remove aux-logic (if not used, red/white stripe)
- 3) Connect pre-crimped flying leads as shown in Figure 5.7 below

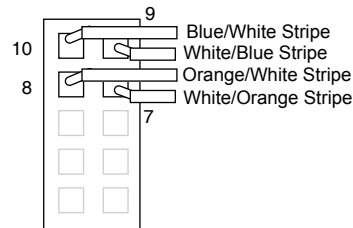

Figure 5.5 Wiring a second PD10-1434-FL3 into the 10-pin wire crimp connector.

5.4.2 Mutli-drop communications connection

Figure 5.6 illustrates the connection schematic for a multi-drop communications system, note that communications ground only connects to the first system MForce.

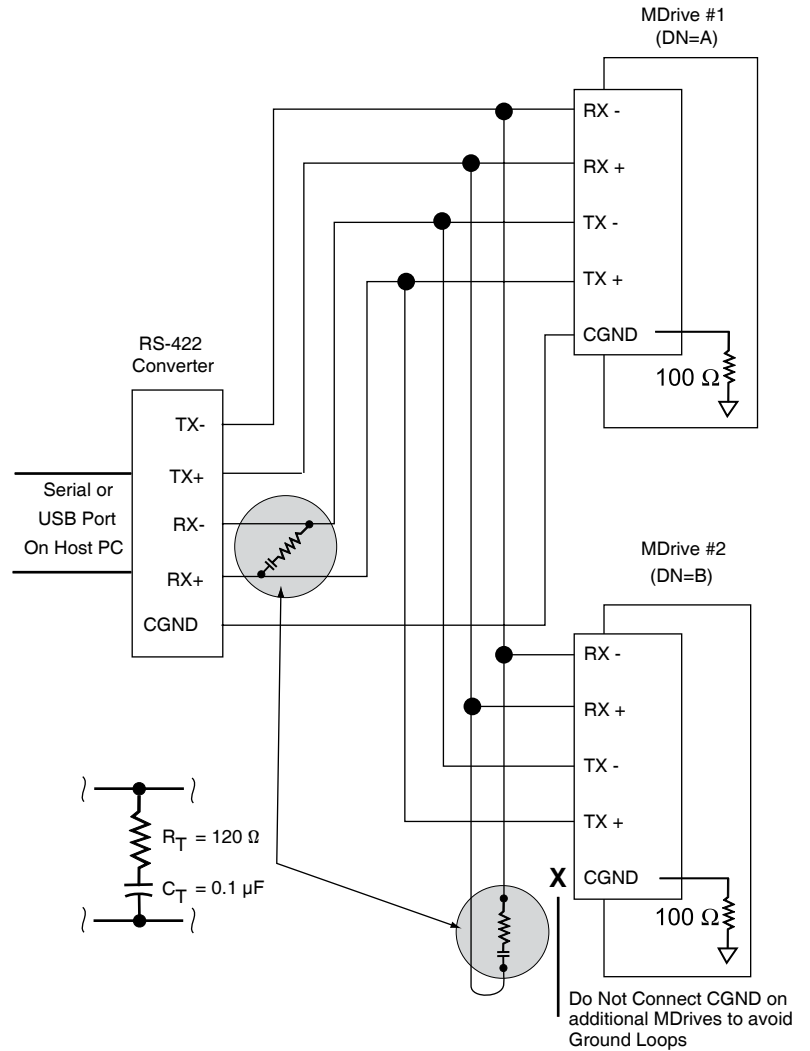

Figure 5.6 Interface for party-mode operation

Data Cable Termination Resistors

Data cable lengths greater than 15 feet (4.5 meters) are susceptible to signal reflection and/or noise. Novanta IMS recommends 120 Ohm termination resistors in series with 0.1 microfarad capacitors at both ends of the receive lines of the communications cables. An example of resistor placement is shown in Figure 5.8. For systems with data cables 15 feet (4.5 meters) or less, the termination resistors are generally not required.

5.4.3 System power connection for a multi-drop system

The power connection schematic in Figure 5.7 represents the recommended power configuration for avoiding communications ground loops

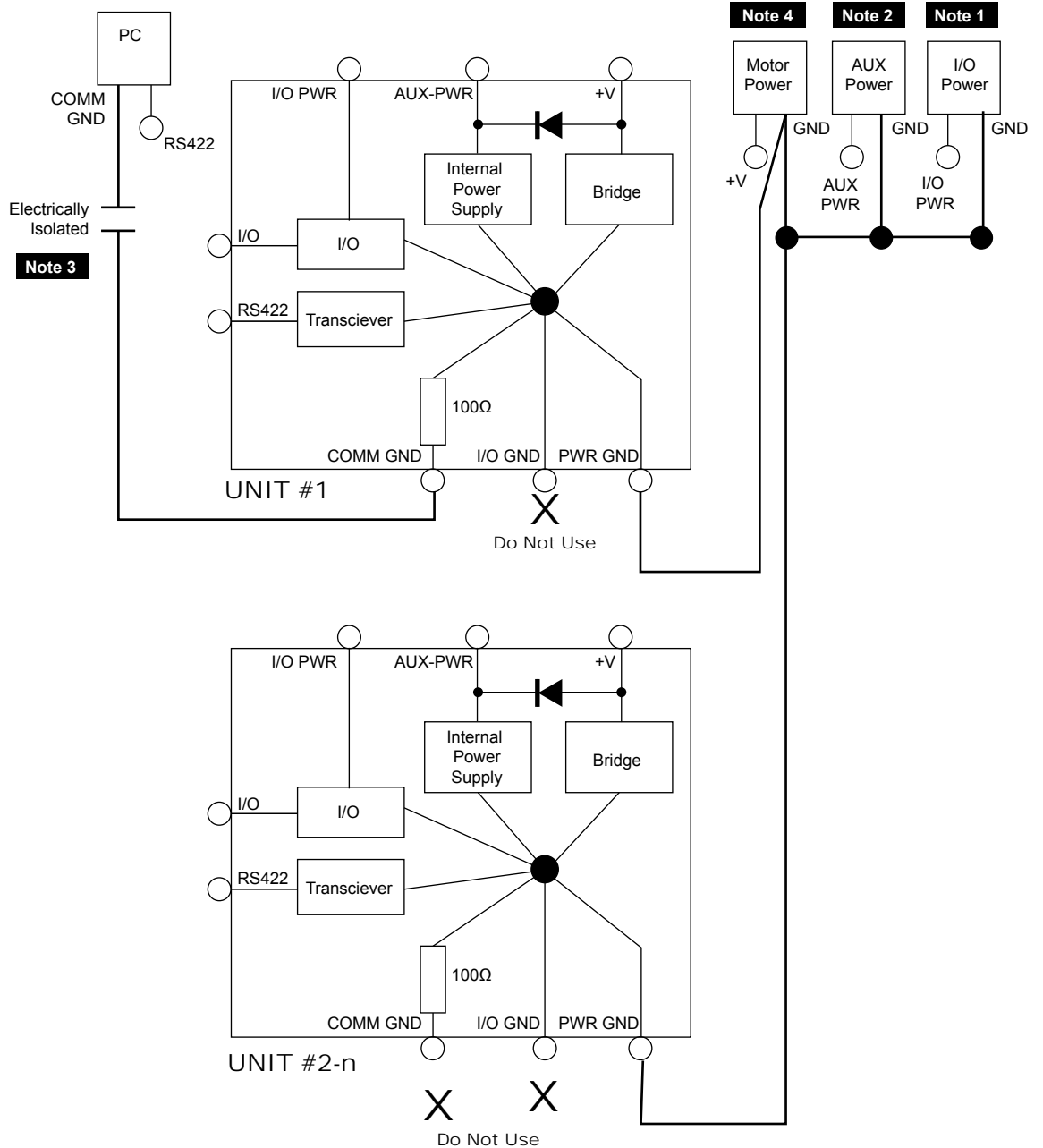

- Note 1** Use AUX-PWR only if position information is needed when motor power is lost AND the MDrive has an encoder
- Note 2** Use I/O Power only if sourcing outputs are required. I/O Power is only available on MDrives with expanded I/O
- Note 3** The isolated communication converter's common MUST be connected to ONLY one MDrive.
- Note 4** If Multiple motor power supplies are used connect the commons together and refer to note three.

Figure 5.7 Power interface for eliminating communications ground loops

5.4.4 Software configuration

Party mode communications requires extensive software configuration and has a specific communications and response format.

This is documented in detail in the MCode software and programming manual, Section 7.

This page intentionally left blank

6 Interfacing CANopen communications

6.1 Features

- CANopen DS-301 and DS-402
- Galvanically isolated communications
- 3 Dynamically mappable process data objects (PDO)
- Layer Setting Services (LSS) to establish node id and baud
- Node guarding
- Heartbeat producer
- Emergency objects
- Upgradable software

6.2 Interfacing the can bus

The Motion Control MForce CANopen communicates using the CAN 2.0B Active Protocol and the CiA DS-301 Application Layer and Communications Profile. The full DS-301 V4.02 Specification may be downloaded free at <http://www.can-cia.org>. The default BAUD rate is 1 Mbit/Sec. The default Node ID is 41h.

6.2.1 CAN bus connections

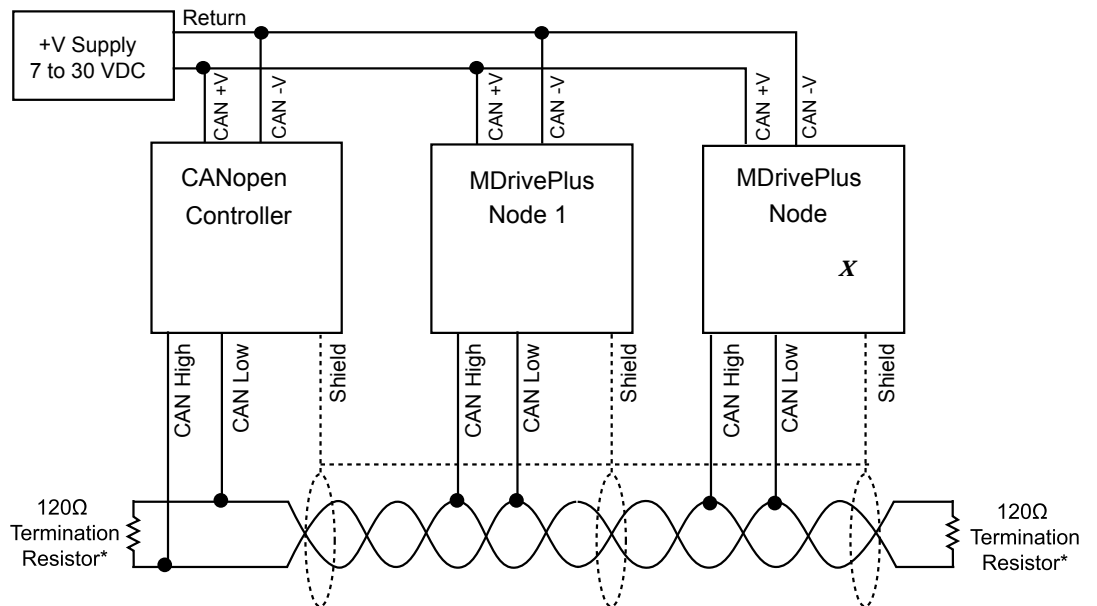

*120Ω Termination Resistors are required between CAN High and CAN Low at both ends of the cabling per ISO-11828

Figure 6.1 Interfacing the CAN bus

6.2.2 Recommended CANopen dongle

In order to use the CANopen Tester tool and upgrade utility for the MForce you must purchase the MD-CC500-000 communications cable. When purchased from Novanta IMS, the user interface software for upgrading and prototyping is included. This is required to upgrade the firmware as updates become available.

This device is also available from phytec at: <http://www.phytec.com/can/hardware/pccaninterface/peakusb.htm>, but does not include the CANopen Tester and upgrader software.

Interface cable construction

To connect the MD-CC500-000 dongle, an interface cable will need to be constructed. The figure below shows the parts required.

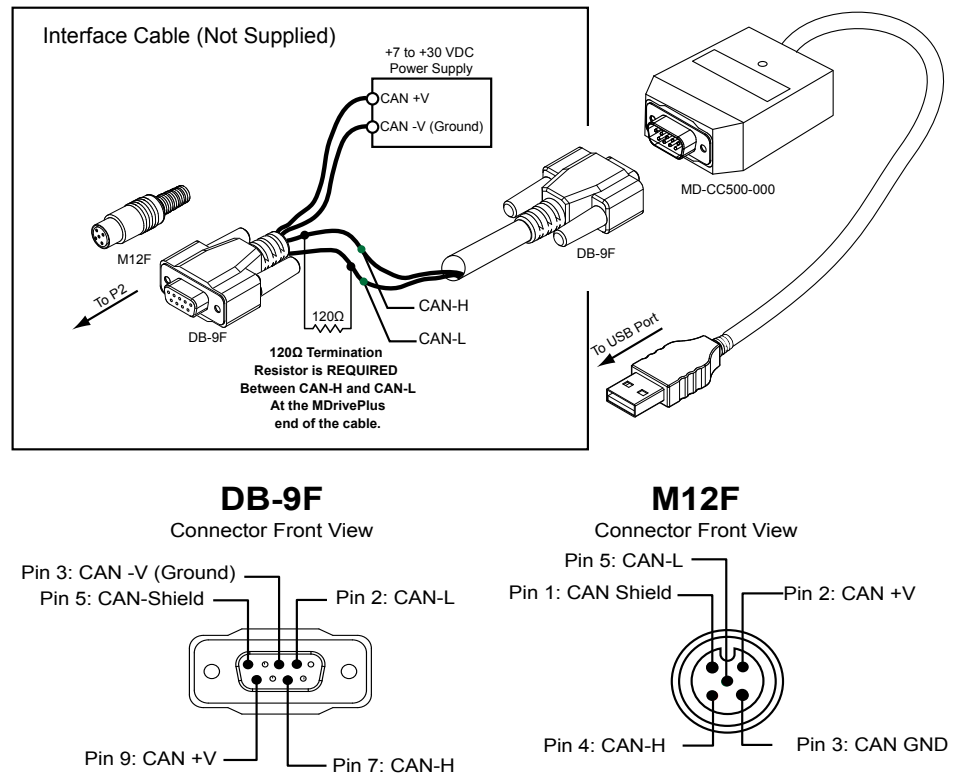

Figure 6.2 MD-CC500-000 USB to CANopen commissioning cable

Installation Instructions

- 1) Install the MD-CC500-000 adapter per the Phytec PCAN-USB Operating Instructions included on the PEAK CD included with the product.
- 2) Install the CANopen Tester software available online at www.novantaims.com
- 3) Using the interface cable (not supplied), connect the MForce to the MD-CC500-000.
- 4) Apply power to the MForce.

6.3 CANopen Tester quick start

6.3.1 Installation

- 1) Download the most recent version of the CANopen Tester from the Novanta IMS web site at www.novantaims.com.
- 2) Extract the files from the archive file.
- 3) Browse to the extracted folder.
- 4) Double-Click the Setup.exe file.
- 5) Follow the prompts to install the program.

6.3.2 Getting Started with CANopen Tester

 CAUTION
<p>CANopen Tester Software</p> <p>Do not use this software unless you accept the responsibility of using the full tool.</p> <p>Only technicians who are familiar with and understand the contents of the manual and the other relevant documentation are authorized to work with the full tool.</p> <p>Damage and/or drive failure may be experienced without full knowledge of the device indexes and features.</p>

The following brief tutorial will cover setting the MForce in profile position. To place the software in advanced mode, select “advanced Mode” from the tools menu in the main interface. A warning dialog will launch with the caution text. If qualified, click “yes” on the dialog. This will launch the advanced features screen.

With the MMForcepowered and the CANopen Tester software launched, select through the following sequence.

See figure 6.3 for button locations.

- A. Click CAN Init
- B. Check “Cycle Reading of indexes.
- C. Click Msg Window Scripts – This will open another window to allow the user to see data being sent to MForce in the following steps.
- D. Click Operation_Toggle three times (this steps through Index 0x6040 Control Word ending with Operation Enabled). This enables the output bridge of the driver.
- E.. Enter the number “1” in the Modes of Operations field, this places the MForce into Profile Position mode.
- F. Enter 512000 into the IDX67AH field, strike the return (Enter) key on your keyboard, the motor should move 10 revolutions.

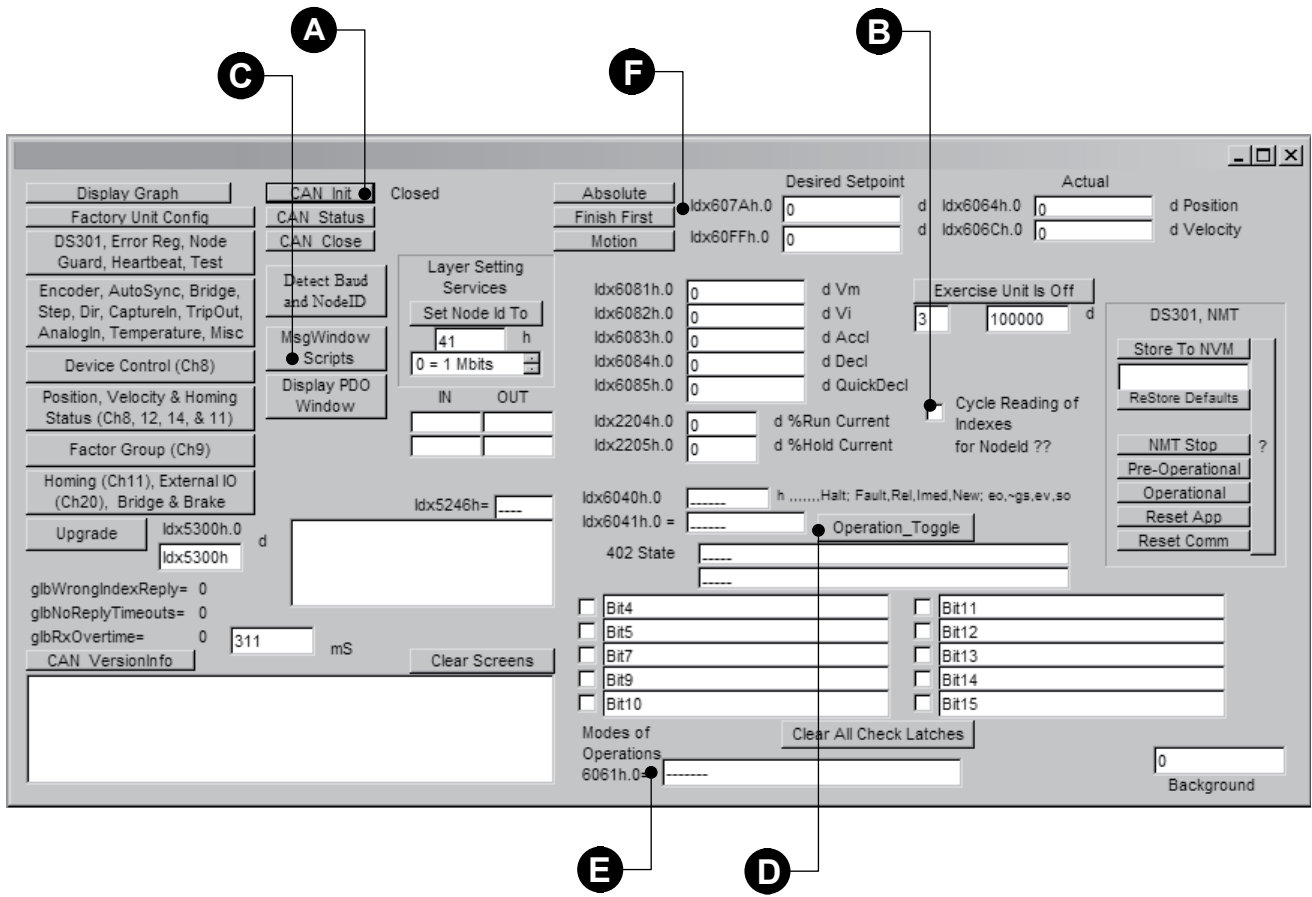



Figure 6.3 CANopen Tester

7 Interfacing I/O

 CAUTION
ELECTRICAL OVERSTRESS
The general purpose I/O is tolerant to +24 VDC. The following listed I/O points are TTL level and only tolerant to +5 VDC:
<ol style="list-style-type: none">1) Step Clock2) Direction3) Capture/Trip4) Remote encoder inputs
Do not exceed +5 VDC on these points.
Failure to follow these instructions can result in equipment damage.

 CAUTION
HOT PLUGGING!
Do not connect or disconnect power, logic, or communications while the device is in a powered state.
Remove DC power by powering down at the AC side of the DC power supply.
Failure to follow these instructions may result in damage to system components!



CONNECTOR OPTIONS

The Motion Control MForce product family has an extensive set of connector options. The purpose of this section is to give a general overview of the I/O interface methods and practices.

Please see the section specific to the MForce product you purchased in the second part of this document for connectors, pin configurations and connectivity options.

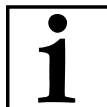

I/O FUNCTIONS AND PARAMETERS

The functions and operational parameters of the Motion Control MForce I/O MUST be configured in software.

For detailed specifications and instruction please reference the MCode Software and Programming manual.

7.1 I/O configurations

The Motion Control MForce product line is available with the following I/O configuration.

I/O set	
General purpose	IO1, IO2, IO3, IO4, IO9, IO10, IO11, IO12 (Sinking or sourcing inputs or outputs)
Dedicated	Capture input/trip output
Analog input	AIN1

Table 7.1 MForce I/O configurations

7.1.1 I/O States

The digital I/O may be defined as either active HIGH or active LOW. When the I/O is configured as active HIGH, the level is +5 to +24 VDC and the state will be read/set as a "1". If the level is 0 VDC, then the state will be read/set as "0". Inversely, if configured as active LOW, then the state of the I/O will be read/set as a "1" when the level is LOW, and "0" when the level is HIGH.

The active HIGH/LOW state is configured by the third parameter of the I/O Setup (S1-4, S9-12) variable. The goal of this I/O configuration scheme is to maximize compatibility between the Motion Control MForce and standard sensors and switches.

7.2 General purpose I/O

The general purpose +5 to +24 VDC I/O must be configured and programmed to general or reserved functions in software. The I/O cannot be exercised without configuration parameters being set:

7.2.1 General purpose input functions

<i>Function</i>	<i>Description</i>
User defined	Input function used to control program branches, subroutine calls or BCD functions when the input bank is used as a group.
Home	Homing input
Limit +	Positive limit input
Limit -	Negative limit input
G0	Executes program at memory address 1 on activation
Soft stop	Stops motion with deceleration and halts program execution
Pause	Pause/resume program execution with motion
Jog +	Jog positive direction
Jog -	Jog negative direction
Reset	Reset program, equivalent to a ^C terminal input.

Table 7.2 General purpose input functions

7.2.2 General purpose output functions

<i>Function</i>	<i>Description</i>
User defined	Output function which can be set to trigger external events from within a program
Moving	Input will be in an active state when the motor is moving
Fault	Activates on an error.
Stall	Activates when a stall is detected (encoder required)
Velocity changing	Activates when accelerating or decelerating

Table 7.3 General purpose output functions

7.2.2 Interfacing sinking inputs

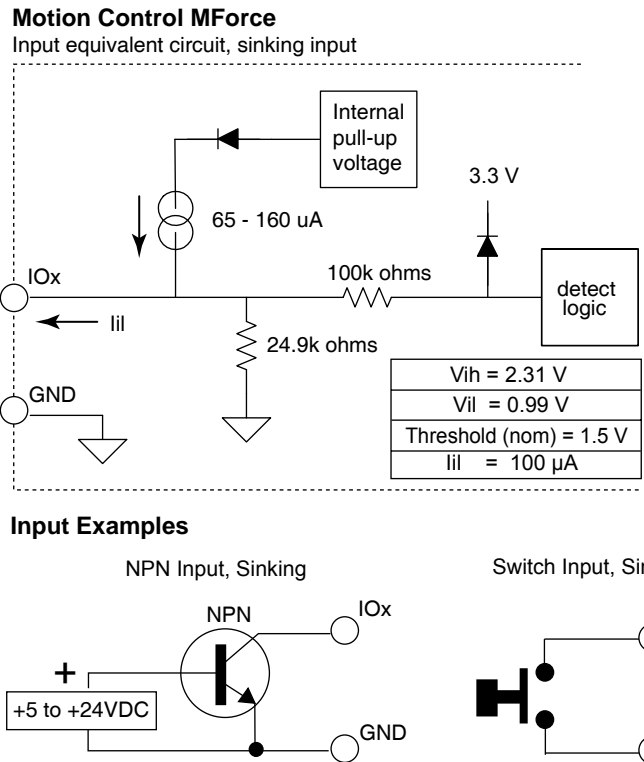

Figure 7.1 Sinking input equivalent circuit and interface examples

7.2.3 Interfacing sinking outputs

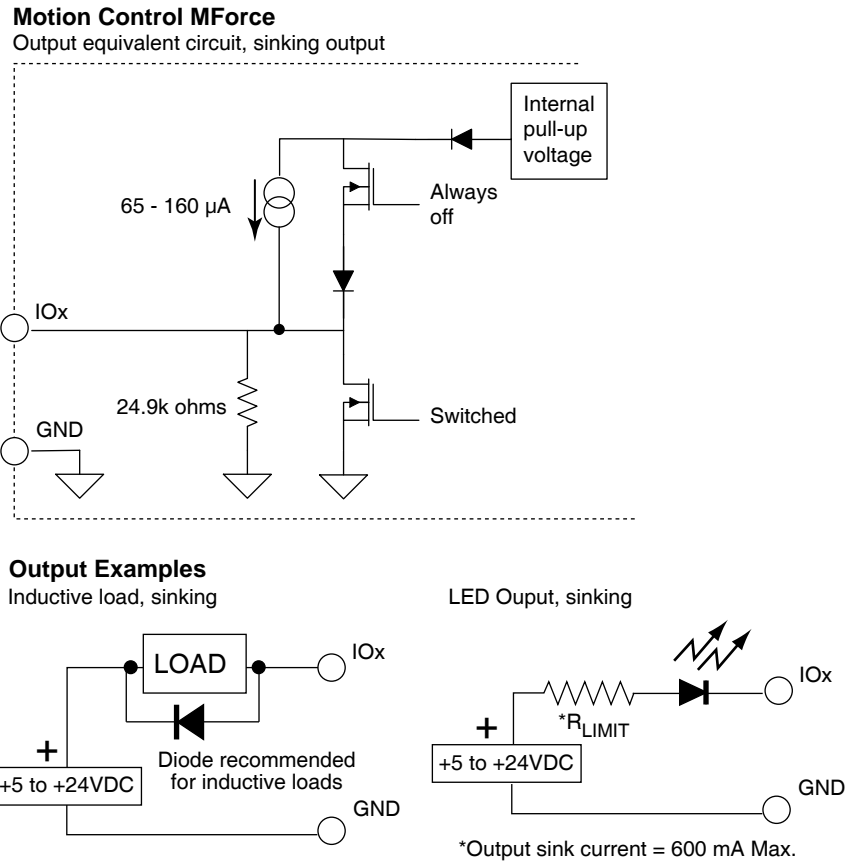
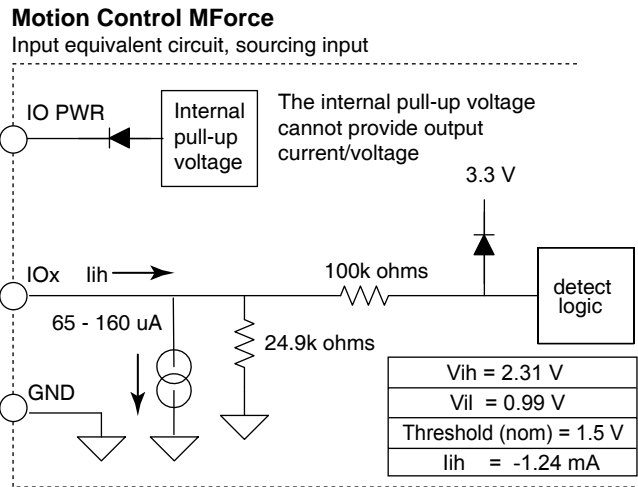

Figure 7.2 Sinking output equivalent circuit and interface examples

7.2.4 Interfacing sourcing inputs



Input Examples

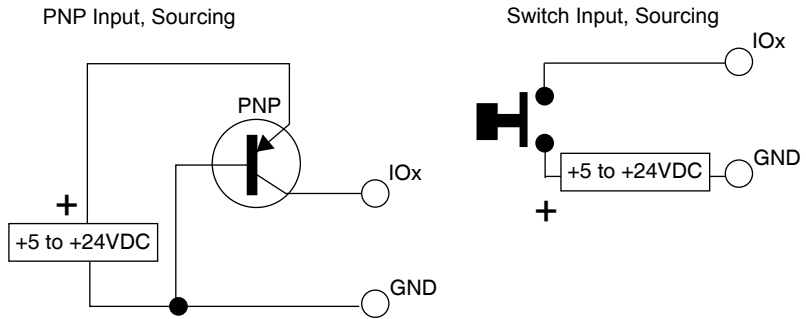
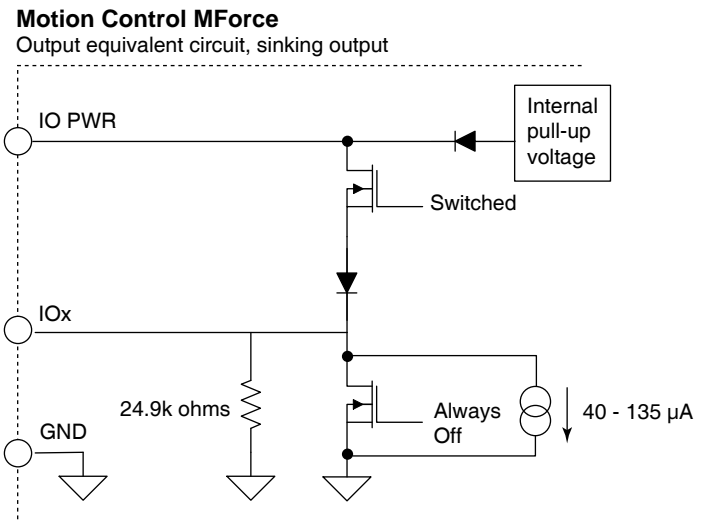

Figure 7.3 Sourcing input equivalent circuit and interface examples

7.2.5 Interfacing sourcing outputs



Output Examples
Inductive load, sourcing

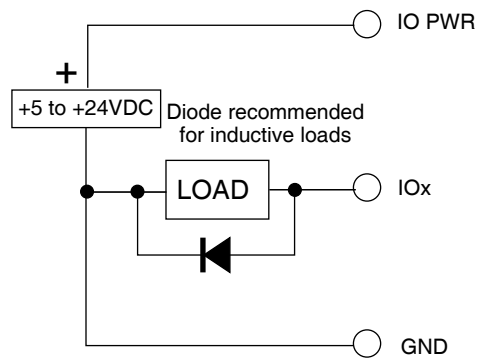

Figure 7.4 Sourcing output equivalent circuit and interface examples

7.2.5 Mixed I/O Example

The application illustrated in Figure 7.5 shows an example of the I/O points being used as mixed inputs and outputs on an MForce with the standard I/O configuration.

IO3 and IO4 are configured as sinking limit inputs, IO2 is set up as a sourcing G0 input with IO1 as a sinking user output. This circuit would operate as automatic reset, where an event inside the program would trigger the user output and run a program located at address 1 in program storage.

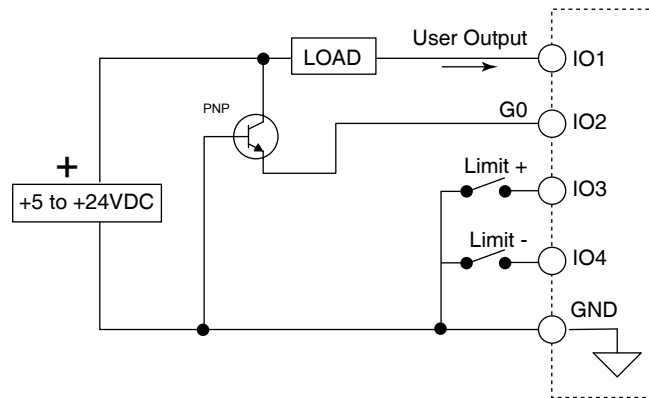

Figure 7.5 Mixed inputs and outputs, standard MForce.

7.2.5 Mixed I/O Example (expanded)

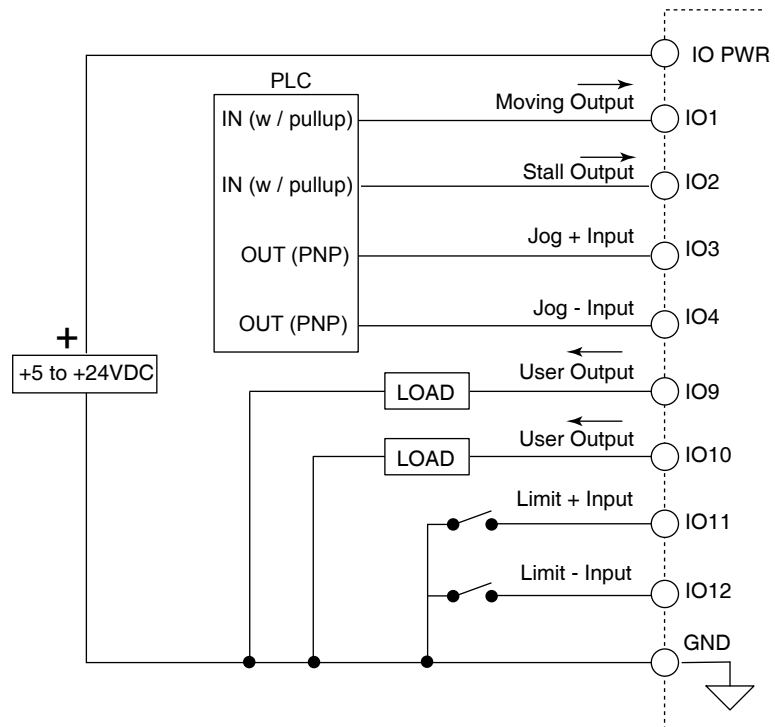

Figure 7.6 Mixed inputs and outputs, expanded MForce.

7.2.6 Interfacing to a bank of I/O points

The I/O can be interfaced to as a bank of inputs or outputs. Available banks are:

- Standard..... Bank 1: IO1-O4
- Expanded Bank 1: IO1-IO4, Bank 2: IO9-IO12
- Expanded + remote encoder Bank 1: IO1-IO4

This feature gives the user to implement sophisticated process control applications by triggering events based upon the BCD state of the I/O.

Binary coded decimal inputs

Figure 7.7 illustrates a TTL interface to I/O banks 1 and 2 on an MForce with the expanded I/O set. These are set to be user defined inputs and the state is read using the following software commands as a binary number. When reading the state of the bank to a terminal it will display as decimal:

- IL — will read the lower input group (IO1 - IO4) where IO1 is the LSB and IO4 is the MSB
- IH — will read the upper input group (IO9 - IO12) where IO9 is the LSB and IO12 is the MSB
- IT — will read both input groups (IO1 - IO12) where IO1 is the LSB and IO12 is the MSB

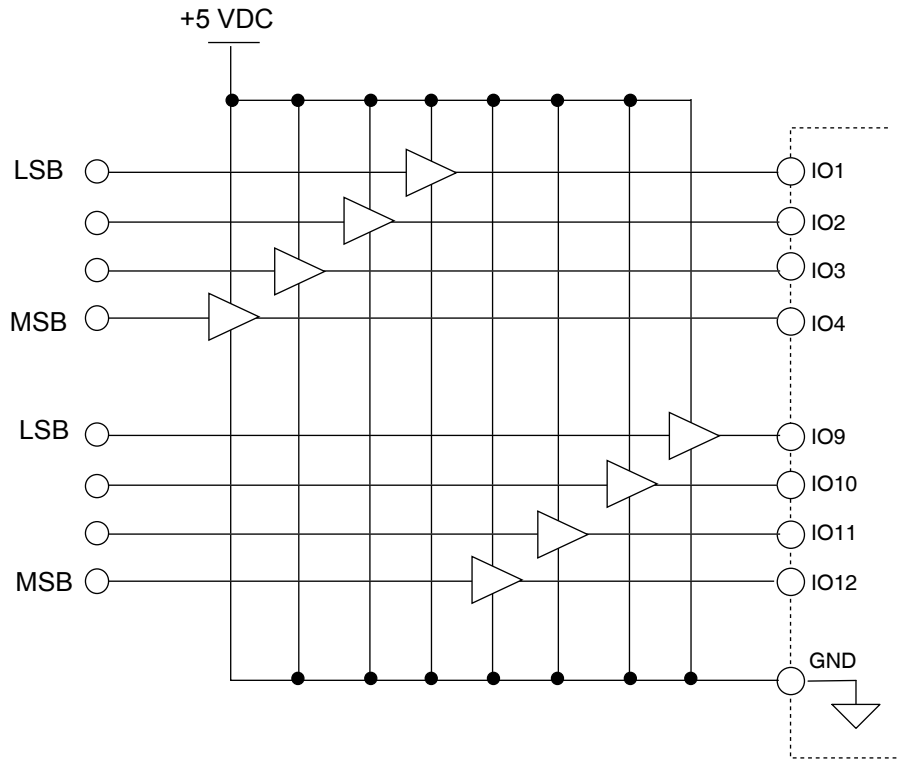

Figure 7.7 TTL interface to I/O banks as a group for BCD program control

Binary coded decimal outputs

Figure 7.8 illustrates an LED interface to I/O banks 1 and 2 on an MForce with the expanded I/O set. This is one possible interface method for illustration purposes. A more practical application would be to interface the outputs to a PLC input module to control external processes from within an MForce program. These are configured as user defined outputs and the state is set using the following software commands as a decimal number. When write the state of the outputs they will be set as a binary number.

- OL — will set the lower output group (IO1 - IO4) where IO1 is the LSB and IO4 is the MSB
- OH — will set the upper output group (IO9 - IO12) where IO9 is the LSB and IO12 is the MSB
- OT — will set both output groups (IO1 - IO12) where IO1 is the LSB and IO12 is the MSB

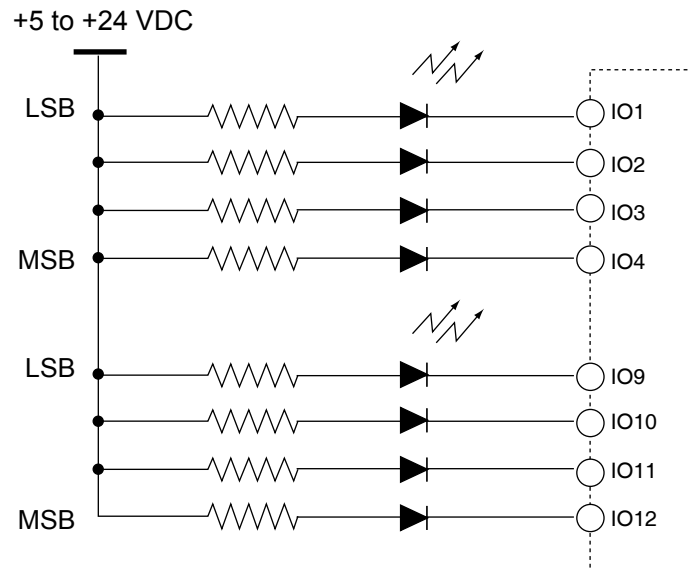

Figure 7.7 Output interface to I/O banks as a group for BCD process control

7.3 Dedicated I/O

⚠ CAUTION
<p>ELECTRICAL OVERSTRESS</p> <p>The I/O points detailed in this subsection are TTL level and only tolerant to +5 VDC:</p> <ol style="list-style-type: none"> 1) Capture/Trip 2) Remote encoder inputs <p>Do not exceed +5 VDC on these points.</p> <p>Failure to follow these instructions can result in equipment damage.</p>

7.3.1 Capture input/trip output

The Capture Input/Trip Output point is a high speed I/O point which can be used for time critical events in motion applications.

Capture Input

When configured as a capture input I/O point 13 has programmable filtering with a range of 50nS to 12.9 μS and has a resolution of 32 bits. The capture input needs to be pulled up to TTL using a 10k ohm resistor.

Trip Output

When configured as a trip output I/O 13 trip speed is 150 nS with 32 bit resolution.

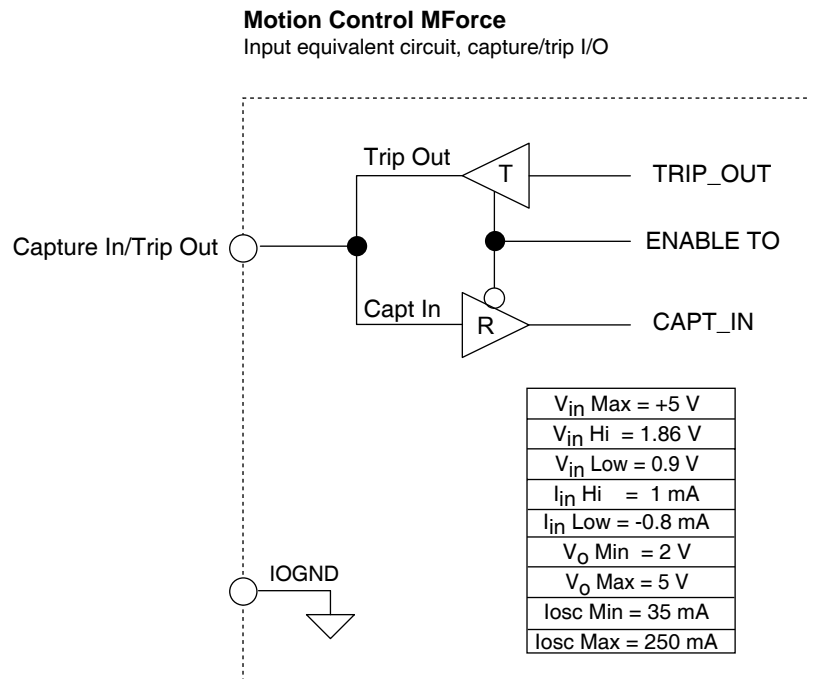

Figure 7.8 Input equivalent circuit, capture/trip I/O

Revision R060923

7.4 Analog input

The analog input of the MForce is configured from the factory as a 0 to 5V, 10 bit resolution input). This offers the user the ability to receive input from temperature, pressure, or other forms of sensors, and then control events based upon the input.

The input can receive input from 0 to +5 VDC, 0 to +10 VDC, 4 to 20 mA and 0 to 20 mA devices.

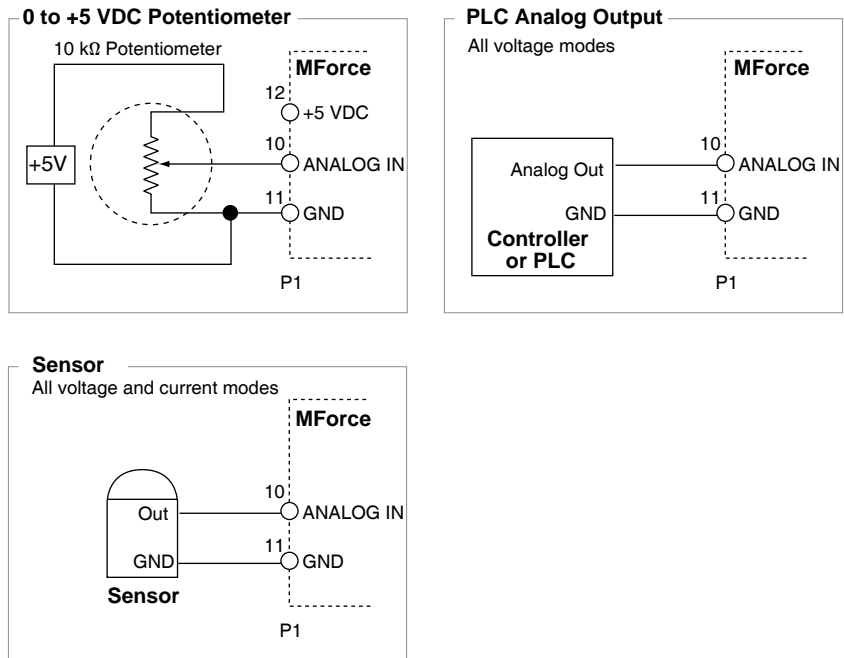

Figure 7.9 Analog input interface

Motion Control MForce MicroDrive



1. Introduction
2. Specifications
3. Mounting Recommendations
4. Interface and Connectivity

This page intentionally left blank

Table of Contents

1	Introduction.....	1-1
1.1	MForce MicroDrive unit overview	1-1
1.2	Product identification	1-2
1.3	Documentation reference	1-3
2	Specifications	2-1
2.1	Mechanical specifications.....	2-1
2.1.1	Dimensional information - inches (mm)	2-1
2.2	General specifications	2-2
2.2.1	Electrical specifications.....	2-2
2.2.2	I/O specifications	2-2
2.2.3	I/O specifications (Plus ² expanded features)	2-3
2.2.4	Communications specifications	2-4
2.2.5	Thermal specifications	2-4
2.2.6	Motion specifications	2-5
2.2.7	Software specifications	2-5
2.2.8	Motor performance curves.....	2-6
2.3	Connectivity specifications/pin assignments — Communications.....	2-7
2.3.1	RS-422/485 communications.....	2-7
2.3.2	CANopen communications option	2-8
2.4	Connectivity specifications/pin assignments - Power and ... I/O.....	2-9
2.4.1	Power and I/O - standard I/O (Plus)	2-9
2.4.2	Power and I/O - expanded I/O (Plus ²)	2-10
2.4.3	Power and I/O - remote encoder (Plus ²).....	2-11
2.5	Connectivity specifications/pin assignments - Motor.....	2-12
2.6	Options.....	2-13
2.7	Connectivity.....	2-13
3	Mounting and connection recommendations.....	3-1
3.1	Mounting.....	3-2
3.2	Layout and interface guidelines.....	3-3
3.2.1	Rules of wiring	3-3
3.2.2	Rules of shielding	3-3
3.3	Recommended wiring.....	3-4
3.3.1	Recommended mating connectors and pins	3-4
4	Connection and interface	4-1
4.1	Connector orientation	4-2
4.2	Interfacing RS422-485 communications	4-3
4.2.1	P2 — 10-pin pressure-fit IDC style connector ...	4-3
4.2.2	P2 — 10-pin friction lock wire crimp	4-4
4.3	Interfacing CANopen communications.....	4-4
4.3.1	P2 — 9-pin d-sub connector (female).....	4-4
4.4	Interfacing DC power.....	4-5
4.4.1	Recommended power supply characteristics	4-5
4.4.2	Recommended wire gauge.....	4-5
4.4.3	P1 — 12' (30.5 cm) flying leads interface.....	4-6
4.4.4	P1 — 7-pin pluggable terminal interface.....	4-6
4.4.5	P1 — 16-pin locking wire crimp interface	4-6
4.4.6	Power Interface using Drive Protection Module	

	DPM75	4-7
4.5	Interfacing I/O.....	4-8
4.5.1	P1 — 12' (30.5 cm) flying leads interface	4-8
4.5.2	P1 — 7-pin pluggable terminal interface.....	4-8
4.5.3	P1 — 16-pin locking wire crimp interface (Plus ² expanded features)	4-9
4.5.4	P1 — 16-pin locking wire crimp interface (remote . encoder).....	4-10
4.6	Interfacing the motor	4-11
4.6.1	P1 — 4-pin locking wire crimp interface	4-11
4.7	Connectivity accessory details	4-12
4.7.1	RS-422/485 communications converter cables.....	4-12
4.7.2	Prototype development cables	4-13
4.7	Mating connector kits	4-15

List of Figures

Figure 1.1	Standard product options	1-2
Figure 2.1	Standard and Expanded features mechanical specifications	2-1
Figure 2.2	NEMA 17 Torque-Speed performance curves	2-6
Figure 2.2	NEMA 17 Torque-Speed performance curves	2-6
Figure 3.1	MForce Microstepping mounting and cabinet layout.....	3-2
Figure 4.1	Connector orientation	4-2
Figure 4.2	DPM75 Drive Protection Module	4-7
Figure 4.3	MD-CC400-000 communications converter cable.....	4-12
Figure 4.4	MD-CC402-001 communications converter cable.....	4-12
Figure 4.5	Multi-drop communications using the PD10-1434-FL3	4-13
Figure 4.6	Wiring a second PD10-1434-FL3 into the 10-pin wire crimp connector.....	4-13
Figure 4.7	Prototype development cable PD16-1417-FL3	4-14
Figure 4.8	Prototype development cable PD04-MF17-FL3.....	4-14

List of Tables

Table 2.1	Electrical specifications	2-2
Table 2.2	I/O specifications.....	2-2
Table 2.3	Expanded I/O specifications.....	2-3
Table 2.4	Communications specifications.....	2-4
Table 2.5	Thermal specifications.....	2-4
Table 2.6	Motion specifications	2-5
Table 2.7	Software specifications.....	2-5
Table 2.8	P2 communications, 10-pin locking wire crimp	2-7
Table 2.9	P2 communications, 10-pin pressure fit IDC/SAMTEC	2-7
Table 2.10	CANopen communications, P2: 9-pin D-sub female (DB-9F).....	2-8
Table 2.11	Power and I/O interface - 12" (308.8.mm) flying leads.....	2-9
Table 2.12	Power and I/O interface - 7-pin pluggable terminal.....	2-9
Table 2.13	P1 Expanded I/O, 14-pin locking wire crimp	2-10
Table 2.14	I/O and remote encoder interface - 16-pin locking wire crimp.....	2-11
Table 2.10	P3 motor, 4-pin locking wire crimp	2-12
Table 4.1	Communications connections, P2 - 10-pin IDC.....	4-3
Table 4.2	P2 communications, 10-pin locking wire crimp	4-4
Table 4.3	CANopen communications, P2: 9-pin D-sub female (DB-9F).....	4-4
Table 4.4	Recommended power supply characteristics.....	4-5
Table 4.5	Recommended power supply wire gauge	4-5
Table 4.6	Power and ground connections, flying leads.....	4-6
Table 4.7	Power and ground connections, 7-pin terminal	4-6
Table 4.8	Power and ground connections, 16-pin locking wire crimp ...	4-6
Table 4.9	I/O connections, flying leads	4-8
Table 4.10	I/O connections, 7-pin terminal.....	4-8
Table 4.11	I/O connections, 16-pin locking wire crimp.....	4-9
Table 4.12	I/O and remote encoder connections, 16-pin locking wire crimp.....	4-10
Table 4.13	Motor connections, 4-pin locking wire crimp	4-11

Page intentionally left blank

1 Introduction

The **Motion Control MForce MicroDrive** offers system designers a cost effective, full featured programmable motion controller integrated with a +12 up to +48 VDC* microstepping driver.

1.1 MForce MicroDrive unit overview

The unsurpassed smoothness and performance delivered by the Motion Control MForce MicroDrive are achieved through advanced 2nd generation current control. By applying innovative techniques to control current flow through the motor, resonance is significantly dampened over the entire speed range and audible noise is reduced.

The MForce MicroDrive accepts a broad input voltage range from +12 up to +48 VDC, delivering enhanced performance and speed. Oversized input capacitors are used to minimize power line surges, reducing problems that can occur with long cable runs and multiple drive systems. An extended operating range of -40° to $+85^{\circ}\text{C}$ provides long life, trouble free service in demanding environments.

Standard features of all Motion Control MForce MicroDrive include four +5 to +24 volt general purpose I/O lines, one 10 bit analog input, 0 to 5MHz step clock rate, 20 microstep resolutions up to 51,200 steps per revolution, and full featured easy-to-program instruction set.

Expanded features of MForce MicroDrive versions include up to eight +5 to +24 volt general purpose I/O lines and the capability of electronic gearing by following a rotary or linear axis at an electronically controlled ratio, or an output clock can be generated fixed to the internal step clock.

Closed loop control is available with an interface to a remotely mounted user-supplied encoder.

The MForce communicates over RS-422/485 which allows for point-to-point or multiple unit configurations utilizing one communication port. Addressing and hardware support up to 62 uniquely addressed units communicating over a single line. Baud rate is selectable from 4.8 to 115.2kbps.

Optional communication protocols include CANopen. The CAN bus is 2.0B active (11 and/or 29 bit) and is capable of all standard frequencies from 10kHz to 1MHz. CANopen features include node guarding, heartbeat producer, SDOs and PDOs. Highlights include variable PDO mapping and extended node identifier.

MForce connectivity has never been easier with options ranging from all-inclusive QuickStart Kits to individual interfacing cables and mating connector kits to build your own cables.

The MForce MicroDrive is a compact, powerful and cost effective motion control solution that will reduce system cost, design and assembly time for a large range of brushless step motor applications.

1.2 Product identification

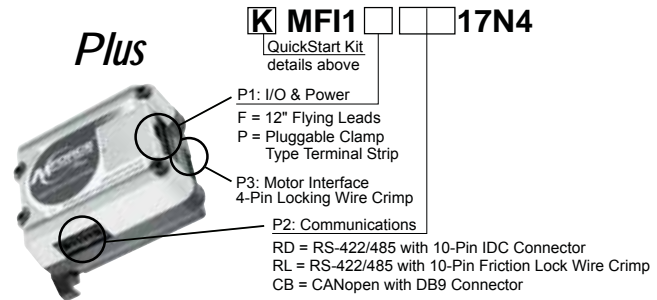

Example: Part Number **MF11PRD17N4** is a Motion Control MForce MicroDrive Plus with pluggable I/O & power interface, RS-422/485 communications with 10-pin IDC connector and 4-pin motor interface.

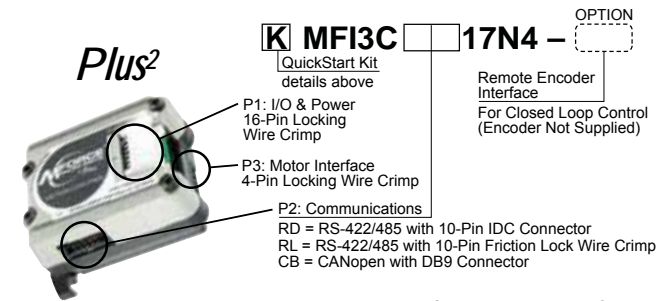

Example: Part Number **MF13CRD17N4** is a Motion Control MForce MicroDrive Plus² with 16-pin I/O & power interface, RS-422/485 communications with 10-pin IDC connector and 4-pin motor interface.

Option: Include -EE to part number for optional interface to remote encoder (not supplied). *Plus² versions only.*

Figure 1.1 Standard product options

1.3 Documentation reference

The following User's manuals are available for the MForce Micro-Drive:

- Product manuals, describes the technical data, installation, configuration and programming of the product.
- Quick Reference, describes the basic wiring, connection and use of this product. The quick reference is shipped in printed form with the product.

This documentation is also available for download at:
www.novantaims.com.

1.4 Product software

The Motion Control MForce MicroDrive integrated motor and driver may be programmed using any standard ASCII txt editor and ANSI terminal emulated. The recommended environment is the Novanta IMS Terminal Interface, which is a combined terminal/program editor tailored for use with Novanta IMS motion control products. This free software may be downloaded at: <https://novantaims.com/dloads/>.

Installation and usages instructions are to be found in the MCode Programming Manual, which is correlated to this document.

Page intentionally left blank

2 Specifications

2.1 Mechanical specifications

2.1.1 Dimensional information - inches (mm)

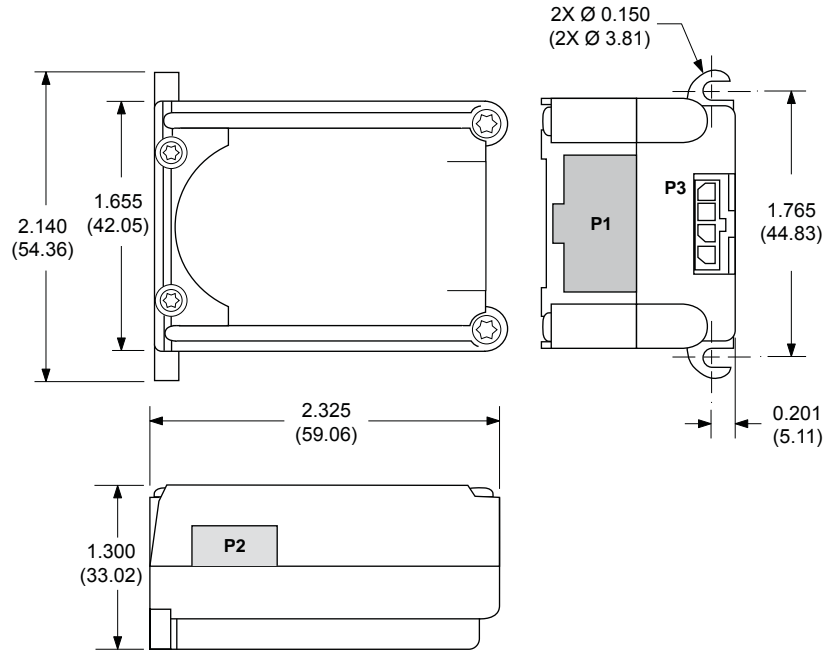

P1 Connector Options

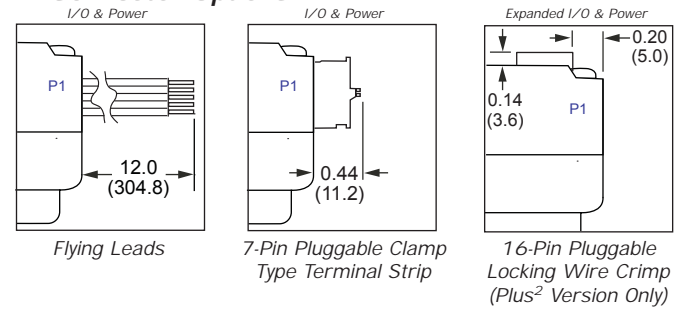

P2 Connector Options

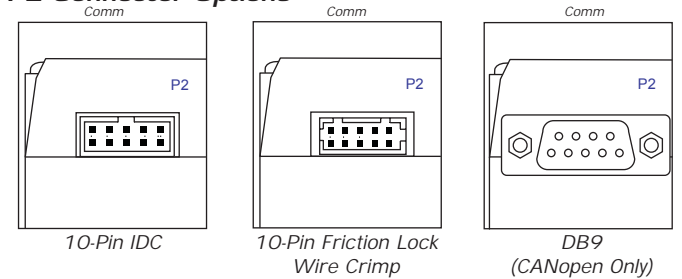

Figure 2.1 Standard and Expanded features mechanical specifications

2.2 General specifications

2.2.1 Electrical specifications

	Condition	Min	Typ	Max	Unit
Input voltage range	—	+12	—	+48	VDC
Power supply current	—	—	—	3.0	A
Output Current	RMS	—	—	3.0	A
		—	—	4.2	A
Aux-Logic Input Voltage**	—	+12	—	+24	VDC
Max Aux-Logic Supply Current (Per MForce)**	—	—	—	194	mA

**per MForce MicroDrive, Actual current depends on voltage and load.*

*** Maintains power to control and feedback circuits [only] when input voltage is removed*

Table 2.1 Electrical specifications

2.2.2 I/O specifications

	Condition	Min	Typ	Max	Unit
General Purpose I/O - Number and Type					
I/O Points 1-4	—	4 I/O points configurable as sinking or sourcing inputs or sinking outputs			
General Purpose I/O - Electrical					
Inputs	—	TTL	—	+24	VDC
Sinking Outputs	—	—	—	+24	VDC
Output Sink Current	One channel	—	—	600	mA
Logic Threshold	Logic 0	—	—	< 0.8	VDC
	Logic 1	—	—	> 2.2	VDC
Protection	Sinking	Over temp, short circuit			
	Sourcing	Transient Over Voltage, Inductive Clamp			
Analog Input					
Resolution	—				
Range	Voltage Mode	0 to +5 VDC, 0 to +10 VDC			
	Current Mode	4 to 20 mA, 0 to 20mA			

Table 2.2 I/O specifications

2.2.3 I/O specifications (Plus² expanded features)

	Condition	Min	Typ	Max	Unit
General Purpose I/O - Number and Type					
I/O Points 1-8	—	8 I/O points (4 if configured for remote encoder) configurable as sinking or sourcing inputs or outputs			
General Purpose I/O - Electrical					
Inputs	Sinking or Sourcing	TTL	—	+24	VDC
Outputs	Sinking	—	—	+24	VDC
	Sourcing	+12	—	+24	VDC
Output Sink Current	One channel	—	—	600	mA
Clock I/O (Step & Direction I/O)					
Types	—	Step/Direction, Up/Down, Quadrature			
Logic Threshold	—	+5 VDC TTL Input, TTL Output (with 2 kΩ Load to Ground)			
Trip Output/Capture Input					
Logic Threshold	—	+5 VDC TTL Input, TTL Output (with 2 kΩ Load to Ground)			
Motion I/O					
Electronic gearing	Range	0.001	—	2.000	
	Resolution	—	—	32	bit
	Threshold	—	—	TTL	VDC
	Filter range	50 nS to 12.9 μS (10 MHz to 38.8 kHz)			
	Secondary clock out ratio	1:1			
High speed position capture	Filter range	50 nS to 12.9 μS (10 MHz to 38.8 kHz)			
	Resolution	—	—	32	bit
High speed trip output	Speed	—	—	150	nS
	Resolution	—	—	32	bit
	Threshold	—	—	TTL	VDC
Optional remote encoder (closed loop)*					
Type	User supplied differential encoder				
Steps per revolution	See motion specifications table				
Resolution	User defined . Note: microsteps/rev = 2X the encoder counts/rev minimum.				

*Remote encoder inputs replace I/O points 4-8 and step and direction I/O

Table 2.3 Expanded I/O specifications

2.2.4 Communications specifications

	Condition	Min	Typ	Max	Unit
RS-422/485 (standard)					
BAUD rate	—	4.8		115.2	kbps
CANopen (optional)					
Type					2.0B active
BAUD rate	—	10 kHz	—	1 MHz	—
Application layer	Version 3.0				DS-301
Device profile	Version 2.0				DSP-402
ID	—				11 or 29 bit
Isolation	—				Galvanic

Table 2.4 Communications specifications

2.2.5 Thermal specifications

		Min	Typ	Max	Unit
Heat sink temperature	non-condensing humidity	-40	—	+85	°C

Table 2.5 Thermal specifications

2.2.6 Motion specifications

Microstep Resolution - Open Loop									
Number of microstep resolutions									20
Available microsteps per revolution									
200	400	800	1000	1600	2000	3200	5000	6400	10000
12800	20000	25000	25600	40000	50000	51200	36000 ¹	21600 ²	25400 ³
1=0.01 deg/μstep 2=1 arc minute/μstep *3=0.001 mm/μstep * 1" per revolution lead screw									
Microstep resolution (closed loop configuration - (optional))									
Steps Per Revolution (Fixed)									51200
Position Resolution									2048
Optional differential encoder (internally mounted)									
Type									Internal, Magnetic
Resolution (Lines)									512
Resolution (Edges)									2048
Counters									
Counter 1 (C1) Type									Position
Counter 2 (C2) Type									Encoder
Resolution									32 bit
Maximum Edge Rate									5 MHz
Velocity									
Range									±5,000,000 Steps/Sec.
Resolution									0.5961 Steps/Sec.
Acceleration/Deceleration									
Range									1.5 x 10 ⁹ Steps/Sec. ²
Resolution									90.9 Steps/Sec. ²

Table 2.6 Motion specifications

2.2.7 Software specifications

Program Storage Type/Size	Flash/6384 Bytes
User Registers	(4) 32 Bit
User Program Labels and Variables	192
Math, Logic and Conditional Functions	+, -, x, ÷, <, >, =, ≤, ≥, AND, OR, XOR, NOT
Branch Functions	Branch and Call (Conditional)
Party Mode Addresses	62
Encoder Functions	Stall Detect, Position Maintenance, Find Index
Predefined I/O Functions	
Input Functions	Home, Limit+, Limit -, Go, Stop, Pause, Jog+, Jog-, Analog Input
Output Functions	Moving, Fault, Stall, Velocity Changing
Trip Functions	Trip on Input, Trip on Position, Trip on Time, Trip Capture

Table 2.7 Software specifications

2.2.8 Motor performance curves

The following performance curves were generated using the motors that we offer and is typical of an MForce paired with motors of similar characteristics. For performance information for non-Novanta IMS motors, please refer to the manufacturer documentation.

NEMA 17 Size

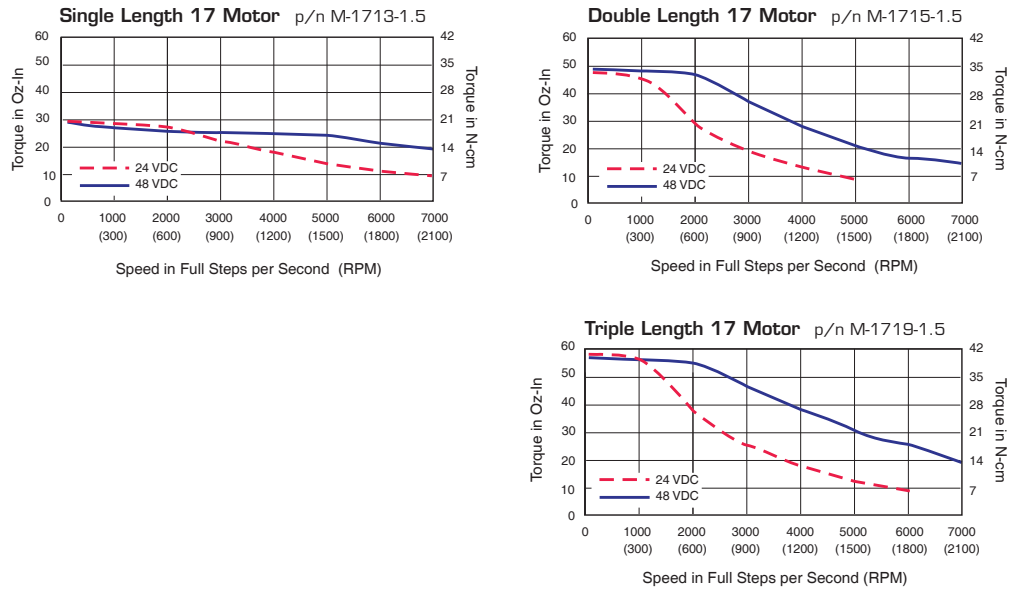

Figure 2.2 NEMA 17 Torque-Speed performance curves

NEMA 23 Size

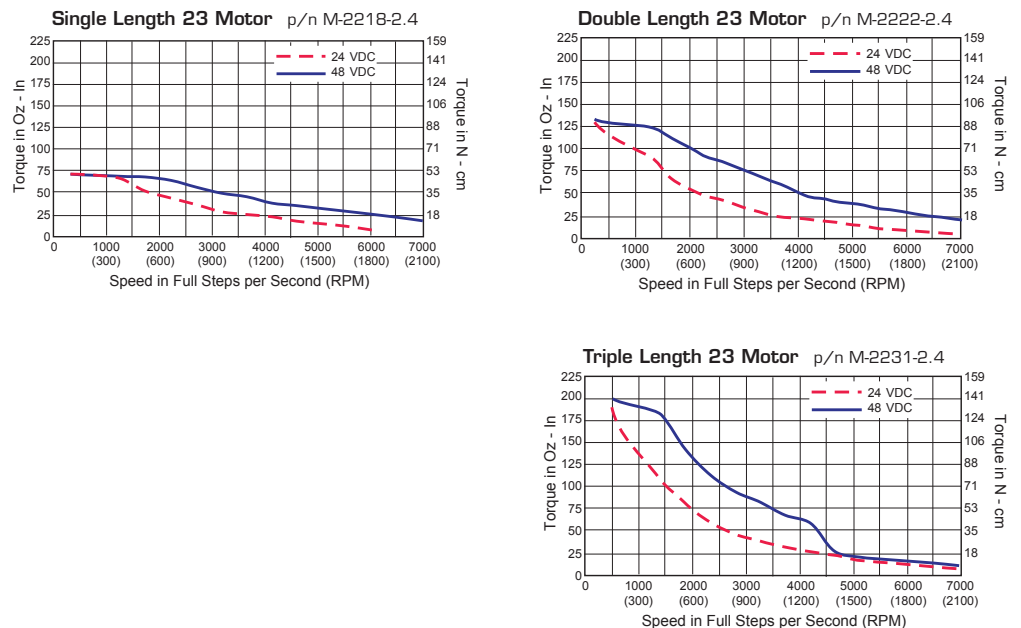

Figure 2.2 NEMA 17 Torque-Speed performance curves

Revision R060923

2.3 Connectivity specifications/pin assignments — Communications

2.3.1 RS-422/485 communications

10-pin friction lock wire crimp

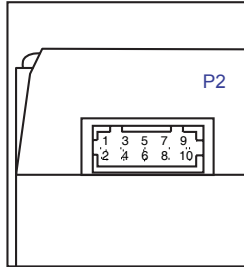

Connectivity Options
 USB to RS-422/485
 Converter:
MD-CC402-001

Mating connector kit:
CK-02

Mfg P/N:
 Shell
Hirose DF11-10DS-2C

Pins
Hirose: DF11-2428SC

Pin #	Function	Description
1	TX +	Transmit plus
2	Comm GND	Communications ground only. Do not ground aux-logic to this pin.
3	RX -	Receive minus
4	TX -	Transmit minus
5	Aux-Logic	Auxiliary logic maintains power to the logic circuitry in the absence of motor power. +12 to +24 VDC input
6	RX +	Receive plus
7	RX +	Receive plus
8	RX -	Receive minus
9	TX +	Transmit plus
10	TX -	Transmit minus

Table 2.8 P2 communications, 10-pin locking wire crimp

10-pin press-fit (IDC style)

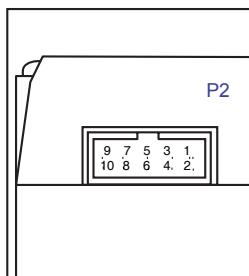

Connectivity Options
 USB to RS-422/485
 Converter:
MD-CC400-001

Mating connector kit:
CK-01

Mfg P/N:
 Shell
SAMTEC: TCSD-05-01-N

Ribbon cable
Tyco: 1-57051-9

Pin #	Function	Description
1	TX +	Transmit plus
2	TX -	Transmit minus
3	RX +	Receive plus
4	RX -	Receive minus
5	Aux-Logic	Auxiliary logic maintains power to the logic circuitry in the absence of motor power. +12 to +24 VDC input
6	RX +	Receive plus
7	RX -	Receive minus
8	TX -	Transmit minus
9	TX +	Transmit plus
10	Comm GND	Communications ground only. Do not ground aux-logic to this pin.

Table 2.9 P2 communications, 10-pin pressure fit IDC/SAMTEC

2.3.2 CANopen communications option

9-pin D-sub female (DB-9F)

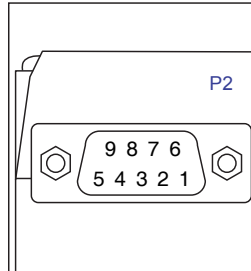

Connectivity Options
 USB to CANopen converter:
 MD-CC500-000

Pin #	Function	Description
1	N/C	Not connected
2	CAN low	CAN_L bus line (low dominant)
3	CAN -V	CAN communications ground
4	N/C	Not connected
5	Shield	Optional CAN shield
6	CAN -V	Optional ground
7	CAN high	CAN_H bus line (high dominant)
8	N/C	Not connected
9	CAN +V	+7 to +30 VDC power supply

Table 2.10 CANopen communications, P2: 9-pin D-sub female (DB-9F)

2.4 Connectivity specifications/pin assignments - Power and I/O

2.4.1 Power and I/O - standard I/O (Plus)

12" (304.8 mm) flying leads

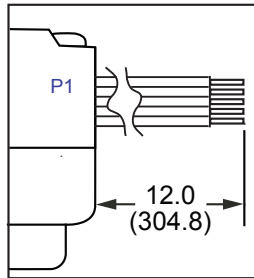

Wire Color	Function	Description
White/yellow	I/O 1	General purpose I/O point 1
White/orange	I/O 2	General purpose I/O point 2
White/violet	I/O 3	General purpose I/O point 3
White/blue	I/O 4	General purpose I/O point 4
Green	Analog input	0 to +5 VDC, 0 to +10 VDC, 4 to 20 mA, 0 to 20 mA
Black	GND	Power and auxiliary ground
Red	+V	Motor power

Table 2.11 Power and I/O interface - 12" (308.8mm) flying leads

7-pin pluggable terminal

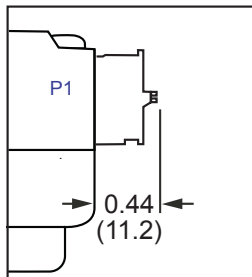

Pin #	Function	Description
1	I/O 1	General purpose I/O point 1
2	I/O 2	General purpose I/O point 2
3	I/O 3	General purpose I/O point 3
4	I/O 4	General purpose I/O point 4
5	Analog input	0 to +5 VDC, 0 to +10 VDC, 4 to 20 mA, 0 to 20 mA
6	GND	Power and auxiliary ground
7	+V	Motor power

Table 2.12 Power and I/O interface - 7-pin pluggable terminal

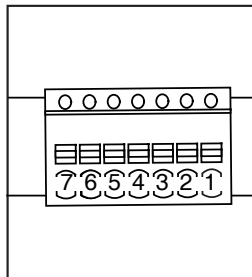

2.4.2 Power and I/O - expanded I/O (Plus²)

16-pin locking wire crimp

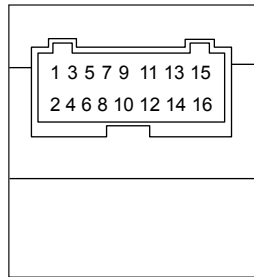
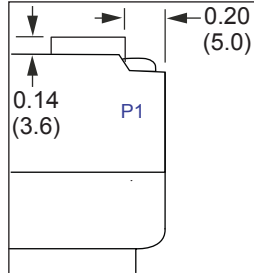

Connectivity Options
 Prototype development cable:
 PD16-1417-FL3

Mating connector kit:
 CK-10

Mfg P/N:
 Shell
 JST PADP-16V-1-S

Pins
 JST SPH-001T0.5L

Pin #	Function	Description
1	I/O power	I/O Power, used with sourcing inputs or outputs.
2	I/O GND	Non-isolated I/O Ground. Common with Power Ground.
3	I/O 1	0 to +24 VDC Programmable I/O Point 1
4	I/O 2	0 to +24 VDC Programmable I/O Point 2
5	I/O 3	0 to +24 VDC Programmable I/O Point 3
6	I/O 4	0 to +24 VDC Programmable I/O Point 4
7	I/O 9	0 to +24 VDC Programmable I/O Point 9
8	I/O 10	0 to +24 VDC Programmable I/O Point 10
9	I/O 11	0 to +24 VDC Programmable I/O Point 11
10	I/O 12	0 to +24 VDC Programmable I/O Point 12
11	Capture/trip I/O	High Speed Capture Input or Trip Output. +5 VDC Logic Level.
12	Analog in	0 to 10 V / 4 to 20 mA / 0 to 20 mA Analog Input.
13	Step/clock I/O	Step clock i/o. Can also be configured as quadrature or clock up/down. +5 VDC logic level.
14	Direction/clock I/O	Direction i/o. Can also be configured as quadrature or clock up/down. +5 VDC logic level.
15	+V	+12 to +48 VDC motor power supply input.
16	Power/aux ground	Power and auxiliary ground

Table 2.13 P1 Expanded I/O, 14-pin locking wire crimp

2.4.3 Power and I/O - remote encoder (Plus²)

16-pin locking wire crimp

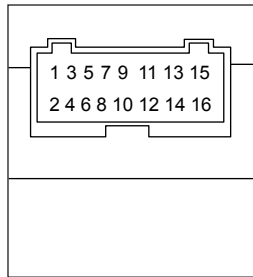
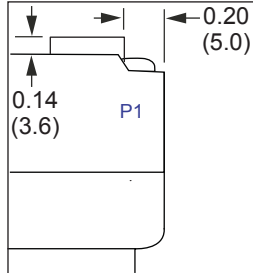

Connectivity Options
 Prototype development cable:
 PD16-1417-FL3

Mating connector kit:
 CK-10

Mfg P/N:
 Shell
 JST PADP-16V-1-S

Pins
 JST SPH-001T0.5L

Pin #	Function	Description
1	I/O power	I/O Power, used with sourcing inputs or outputs.
2	I/O GND	Non-isolated I/O Ground. Common with Power Ground.
3	I/O 1	0 to +24 VDC Programmable I/O Point 1
4	I/O 2	0 to +24 VDC Programmable I/O Point 2
5	I/O 3	0 to +24 VDC Programmable I/O Point 3
6	I/O 4	0 to +24 VDC Programmable I/O Point 4
7	CH A+	Channel A+ encoder input. +5 VDC logic level
8	CH A-	Channel A- encoder input. +5 VDC logic level
9	CH B+	Channel B+ encoder input. +5 VDC logic level
10	CH B-	Channel B- encoder input. +5 VDC logic level
11	Capture/trip I/O	High Speed Capture Input or Trip Output. +5 VDC Logic Level.
12	Analog in	0 to 10 V / 4 to 20 mA / 0 to 20 mA Analog Input.
13	IDX+	Index mark + encoder input. +5 VDC logic level
14	IDX-	Index mark - encoder input. +5 VDC logic level
15	+V	+12 to +48 VDC motor power supply input.
16	Power/aux ground	Power and auxiliary ground

Table 2.14 I/O and remote encoder interface - 16-pin locking wire crimp

2.5 Connectivity specifications/pin assignments - Motor

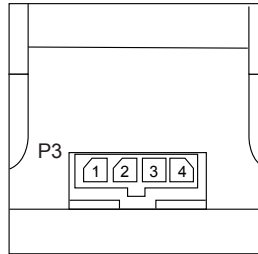

Pin #	Function	Description
1	ØA	Phase A return
2	ØA	Phase A output
3	ØB	Phase B return
4	ØB	Phase B output

Table 2.10 P3 motor, 4-pin locking wire crimp

Connectivity Options

Prototype development cable
 PD04-MF17-FL3

Mating connector kit:
 CK-06

Mfg P/N:
 Shell
 Tyco 1445022-4
 Pins
 Tyco 1-794610-1

2.6 Options

Drive Protection Module The function of the DPM75 Drive Protection Module is to limit the surge current and voltage to a safe level when DC input power is switched on and off to the MForce.

Remote Encoder (Plus² versions only) Motion Control MForce MicroDrive versions are available with differential encoder inputs for use with a remote encoder (not supplied).

2.7 Connectivity

QuickStart kit For rapid design verification, all-inclusive QuickStart Kits have communication converter, prototype development cable(s), instructions and CD for MForce initial functional setup and system testing.

Communication Converters Electrically isolated, in-line converters pre-wired with mating connectors to conveniently set/program communication parameters for a single MForce product via a PC's USB port. Length 12.0' (3.6m).

Mates to connector:

- P2 10-pin pressure-fit IDC MD-CC400-001
- P2 5-pin M12 circular MD-CC401-001
- P2 10-pin wire crimp MD-CC402-001

Prototype Development Cables Speed test/development with pre-wired mating connectors that have flying leads other end. Length 10.0' (3.0m).

Mates to connector:

- P2 10-pin wire crimp PD10-1434-FL3
- P1 16-pin wire crimp PD16-1417-FL3
- P1 19-pin M23 circular (straight) MD-CS100-000
- P1 19-pin M23 circular (right-angle) MD-CS101-000

Mating Connector Kits Use to build your own cables. Kit contains 5 mating shells with pins. Cable not supplied. Manufacturer's crimp tool recommended.

Mates to connector:

- P2 10-pin pressure-fit IDC CK-01
- P2 10-pin wire crimp CK-02
- P1 16-pin wire crimp CK-10

Revision R060923

Page intentionally left blank

3 Mounting and connection recommendations

⚠ DANGER**EXPOSED SIGNALS**

Hazardous voltage levels may be present if using an open frame power supply to power the product.

Failure to follow these instructions will result in death or serious injury.

⚠ CAUTION**SWITCHING DC POWER/HOT PLUGGING**

Do not connect or disconnect power, logic, or communications while the device is in a powered state.

Remove DC power by powering down at the AC side of the DC power supply.

Failure to follow these instructions can result in equipment damage.

⚠ CAUTION**LEAD RESTRAINT**

Some MForce MicroDrive mounting configurations require that the MForce MicroDrive move along the screw. Ensure that all cabling is properly restrained to provide strain relief on connection points..

Failure to follow these instructions can result in equipment damage.

⚠ CAUTION**THERMAL MANAGEMENT**

Do not remove the thermal pad attached to the mounting surface of the MForce MicroDrive. It is essential to maintaining a safe driver temperature at full current..

Failure to follow these instructions can result in equipment damage.

3.1 Mounting

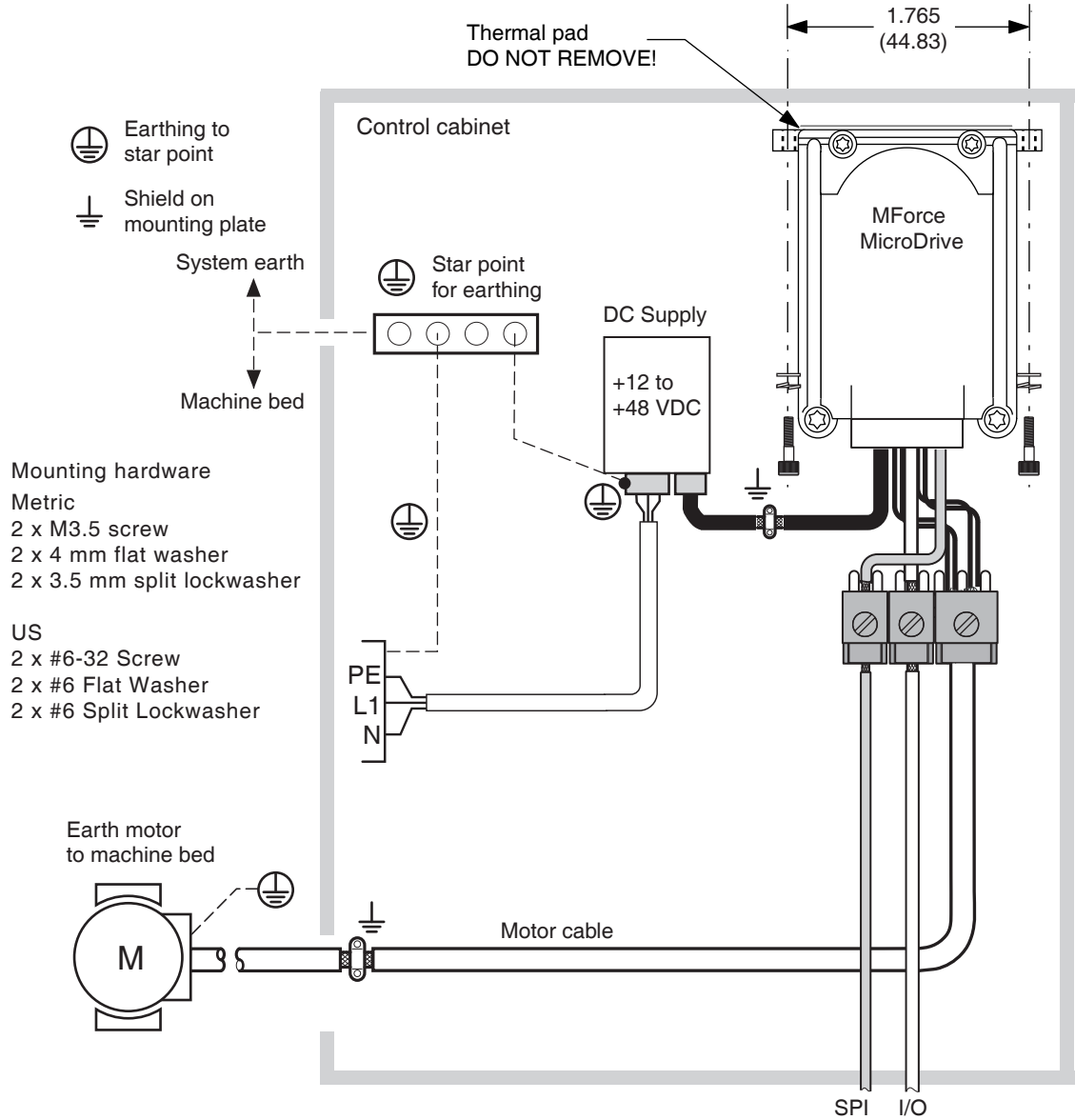

Figure 3.1 MForce Microstepping mounting and cabinet layout

3.2 Layout and interface guidelines

Logic level cables must not run parallel to power cables. Power cables will introduce noise into the logic level cables and make your system unreliable.

Logic level cables must be shielded to reduce the chance of EMI induced noise. The shield needs to be grounded at the signal source to earth. The other end of the shield must not be tied to anything, but allowed to float. This allows the shield to act as a drain.

Power supply leads to the MForce MicroDrive need to be twisted. If more than one driver is to be connected to the same power supply, run separate power and ground leads from the supply to each driver.

3.2.1 Rules of wiring

- Power Supply and Motor wiring should be shielded twisted pairs, and run separately from signal-carrying wires.
- A minimum of one twist per inch is recommended.
- Motor wiring should be shielded twisted pairs using 20 gauge, or for distances of more than 5 feet, 18 gauge or better.
- Power ground return should be as short as possible to established ground.
- Power supply wiring should be shielded twisted pairs of 18 gauge for less than 4 amps DC and 16 gauge for more than 4 amps DC.

3.2.2 Rules of shielding

- The shield must be tied to zero-signal reference potential. It is necessary that the signal be earthed or grounded, for the shield to become earthed or grounded. Earthing or grounding the shield is not effective if the signal is not earthed or grounded.
- Do not assume that Earth ground is a true Earth ground. Depending on the distance from the main power cabinet, it may be necessary to sink a ground rod at the critical location.
- The shield must be connected so that shield currents drain to signal-earth connections.
- The number of separate shields required in a system is equal to the number of independent signals being processed plus one for each power entrance.
- The shield should be tied to a single point to prevent ground loops.
- A second shield can be used over the primary shield; however, the second shield is tied to ground at both ends.

3.3 Recommended wiring

The following wiring/cabling is recommended for use with the MForce MicroDrive:

Logic Wiring.....	22 AWG
Wire Strip Length.....	0.25" (6.0 mm)
Power and Ground	20 AWG
Motor Wiring	20 AWG

3.3.1 Recommended mating connectors and pins

<i>Communications</i>	10-pin IDC (P2).....	SAMTEC TCSD-05-01-N
	Recommended ribbon cable.....	Tyco 1-57051-9

<i>Logic and Power</i>	The following mating connectors are recommended for the MForce	
	12-pin Locking Wire Crimp Connector Shell.....	Tyco 1-794617-2
	Crimp Pins	Tyco 794610-1

<i>Motor</i>	The following mating connectors are recommended for the MForce	
	4-pin Locking Wire Crimp Connector Shell.....	Tyco 1445022-4
	Crimp Pins	Tyco 1-794610-1

4 Connection and interface

 DANGER**EXPOSED SIGNALS**

Hazardous voltage levels may be present if using an open frame power supply to power the product.

Failure to follow these instructions will result in death or serious injury.

 CAUTION**SWITCHING DC POWER/HOT PLUGGING**

Do not connect or disconnect power, logic, or communications while the device is in a powered state.

Remove DC power by powering down at the AC side of the DC power supply.

Failure to follow these instructions can result in equipment damage.

4.1 Connector orientation

The illustration below shows the connector positions and orientation with regard to the location of pin 1.

All connector drawings in this section will show this orientation.

10-pin IDC

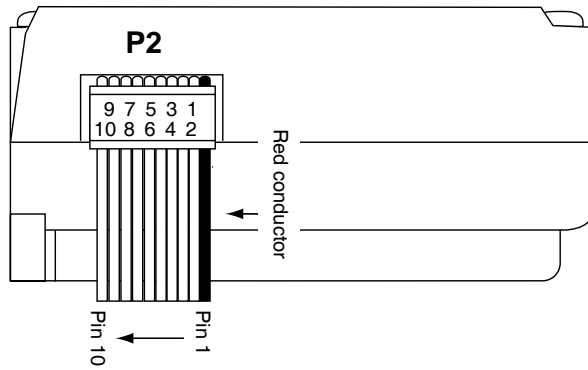

Pluggable terminal or flying leads

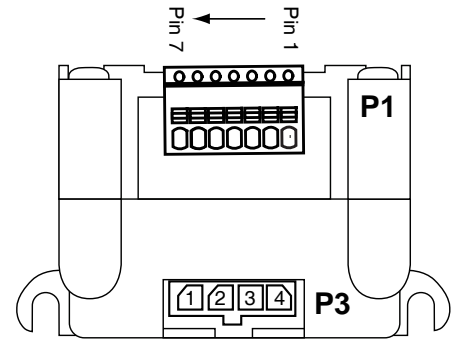

10-pin wire crimp

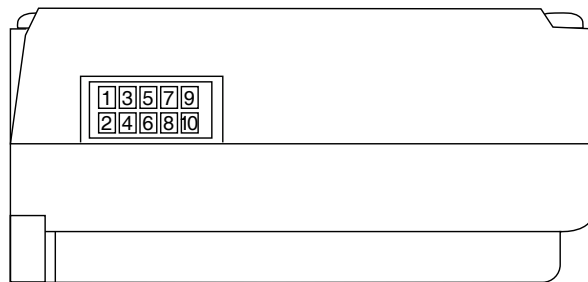

16-pin wire crimp

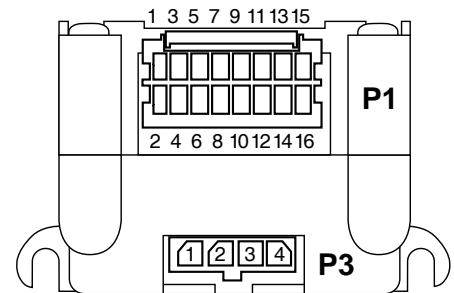

Figure 4.1 Connector orientation

4.2 Interfacing RS422-485 communications

For general RS422/485 single and party mode communications practices please see Part 1 Section 5 of this document.

⚠ CAUTION
COMMUNICATIONS GROUND LOOPS
To avoid ground loops in the system only connect communications ground to the first MForce in the system. Do not connect communications ground on subsequent MForces.
Failure to follow these instructions may result in damage to system components!

⚠ CAUTION
HOT PLUGGING!
Do not connect or disconnect communications while the device is in a powered state.
Failure to follow these instructions may result in damage to system components!

4.2.1 P2 — 10-pin pressure-fit IDC style connector

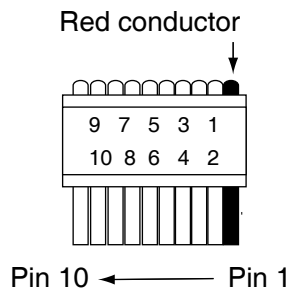

Pin #	Function	Description
1	TX +	Transmit plus
2	TX -	Transmit minus
3	RX +	Receive plus
4	RX -	Receive minus
5	Aux-Logic	Auxiliary logic maintains power to the logic circuitry in the absence of motor power. +12 to +24 VDC input
6	RX +	Receive plus
7	RX -	Receive minus
8	TX -	Transmit minus
9	TX +	Transmit plus
10	Comm GND	Communications ground only. Do not ground aux-logic to this pin.

Table 4.1 Communications connections, P2 - 10-pin IDC

Connectivity accessories

- Mating connector kit CK-01
(contains 5 connector shells, ribbon cable not included)
- Communications converter cable (10'/3.0 m) MD-CC400-001

Revision R060923

4.2.2 P2 — 10-pin friction lock wire crimp

----- Use to connect second device

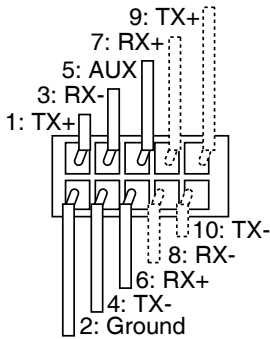

Pin #	Function	Description
1	TX +	Transmit plus
2	Comm GND	Communications ground only. Do not ground aux-logic to this pin.
3	RX -	Receive minus
4	TX -	Transmit minus
5	Aux-Logic	Auxiliary logic maintains power to the logic circuitry in the absence of motor power. +12 to +24 VDC input
6	RX +	Receive plus
7	RX +	Receive plus
8	RX -	Receive minus
9	TX +	Transmit plus
10	TX -	Transmit minus

Table 4.2 P2 communications, 10-pin locking wire crimp

Connectivity accessories

Mating connector kit CK-02
(contains 5 connector shells, ribbon cable not included)

Communications converter cable (10'/3.0 m) MD-CC402-001

4.3 Interfacing CANopen communications

4.3.1 P2 — 9-pin d-sub connector (female)

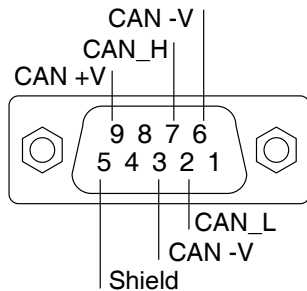

Pin #	Function	Description
1	N/C	Not connected
2	CAN low	CAN_L bus line (low dominant)
3	CAN -V	CAN communications ground
4	N/C	Not connected
5	Shield	Optional CAN shield
6	CAN -V	Optional ground
7	CAN high	CAN_H bus line (high dominant)
8	N/C	Not connected
9	CAN +V	+7 to +30 VDC power supply

Table 4.3 CANopen communications, P2: 9-pin D-sub female (DB-9F)

Connectivity accessories

Communications converter cable MD-CC500-000

4.4 Interfacing DC power

See part 1 of this document, section 3, for recommended power cable configurations.

⚠ CAUTION

OVER VOLTAGE

The DC voltage range for the MForce MicroDrive is +12 to +48 VDC. Ensure that motor back EMF is factored into your power supply size calculations.

Allow 3.0 A maximum power supply output current per MForce in the system. Actual power supply current will depend on voltage and load.

Failure to follow these instructions can result in equipment damage.

4.4.1 Recommended power supply characteristics

Voltage range	+12 to +48 VDC
Type	Unregulated linear
Ripple	± 5%
Output current	2.0 A (per MForce MicroDrive)

Table 4.4 Recommended power supply characteristics

4.4.2 Recommended wire gauge

Cable Length: Feet (meters)	10 (3.0)	25 (7.6)	50 (15.2)	75 (22.9)	100 (30.5)
Amps Peak	Minimum AWG				
1 Amp Peak	20	20	18	18	18
2 Amps Peak	20	18	16	14	14

Table 4.5 Recommended power supply wire gauge

4.4.3 P1 — 12' (30.5 cm) flying leads interface

<i>Wire Color</i>	
Red	Motor power supply
Black	Power ground

Table 4.6 Power and ground connections, flying leads

4.4.4 P1 — 7-pin pluggable terminal interface

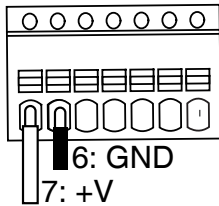

<i>Pin #</i>	
6	Power ground
7	Motor power supply

Table 4.7 Power and ground connections, 7-pin terminal

4.4.5 P1 — 16-pin locking wire crimp interface

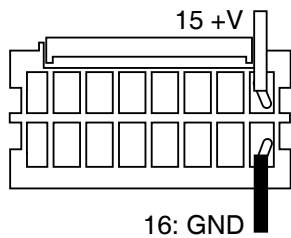

<i>Pin Numbers</i>	<i>Signal</i>	<i>Prototype development cable wire colors</i>
15	+12 to + 48 VDC	Red
16	Power and auxiliary ground	Black

Table 4.8 Power and ground connections, 16-pin locking wire crimp

Connectivity accessories

- Mating connector kitCK-10
(contains 5 connector shells and the appropriate quantity of pins to make 5 cables)
- Prototype development cable (10'/3.0 m)..... PD16-1417-FL3

Manufacturer (JST) part numbers

- Connector shell.....PADP-16V-1-S
- Pins.....SPH-001T0.5L04

4.4.6 Power Interface using Drive Protection Module DPM75

The DPM75 Drive Protection Module will limit surge currents for up to three (3) MForce MicroDrive units at up to 48 VDC to allow switching DC Power.

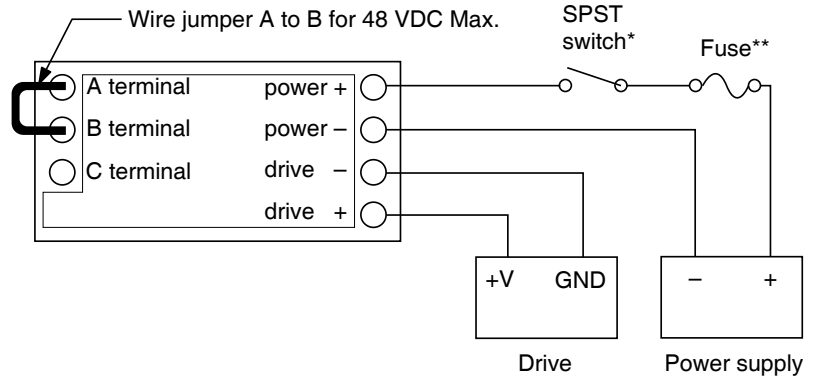

* Do not switch negative side of supply

**Fuse = 6.3 Amp slow blow (recommended: Bussman S505-6.3A or Littelfuse 215006.3). The fuse is optional.

Figure 4.2 DPM75 Drive Protection Module

4.5 Interfacing I/O

See part 1 of this document, section 4, for I/O interface configurations and methods.

CAUTION
ELECTRICAL OVERSTRESS
The general purpose I/O is tolerant to +24 VDC. The following listed I/O point is TTL level and only tolerant to +5 VDC:
<ol style="list-style-type: none"> 1) Capture/Trip 2) Step/Direction 3) Remote encoder inputs
Do not exceed +5 VDC on these points.
Failure to follow these instructions can result in equipment damage.

4.5.1 P1 — 12' (30.5 cm) flying leads interface

<i>Wire Color</i>	<i>Signal</i>
White/yellow	General purpose I/O 1
White/orange	General purpose I/O 2
White/violet	General purpose I/O 3
White/blue	General purpose I/O 4
Green	Analog input

Table 4.9 I/O connections, flying leads

4.5.2 P1 — 7-pin pluggable terminal interface

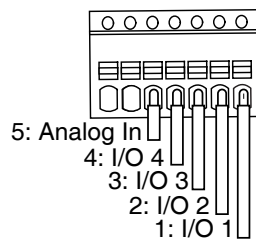

<i>Pin number</i>	<i>Signal</i>
1	General purpose I/O 1
2	General purpose I/O 2
3	General purpose I/O 3
4	General purpose I/O 4
5	Analog input

Table 4.10 I/O connections, 7-pin terminal

4.5.3 P1 — 16-pin locking wire crimp interface (Plus² expanded features)

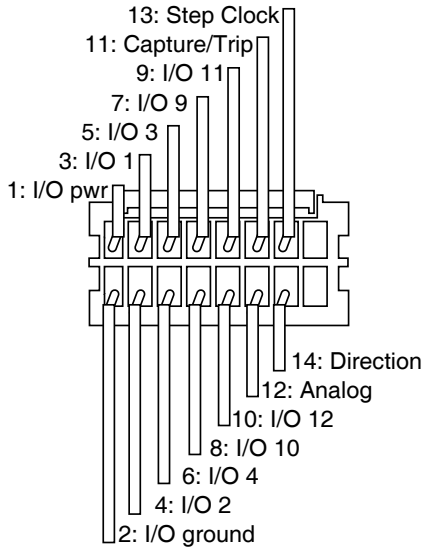

Pin Numbers	Signal	Prototype development cable wire colors (twisted pairs)
1	I/O power	Red
2	I/O ground	White
3	General purpose I/O 1	Orange
4	General purpose I/O 2	Black
5	General purpose I/O 3	Brown
6	General purpose I/O 4	Black
7	General purpose I/O 9	Yellow
8	General purpose I/O 10	Black
9	General purpose I/O 11	Blue
10	General purpose I/O 12	Black
11	Capture output/trip input	Green
12	Analog input	Black
13	Step clock I/O	White
14	Direction clock I/O	Black

Table 4.11 I/O connections, 16-pin locking wire crimp

Connectivity accessories

Mating connector kit CK-10
 (contains 5 connector shells and the appropriate quantity of pins to make 5 cables)

Prototype development cable (10'/3.0 m)..... PD16-1417-FL3

Manufacturer (JST) part numbers

Connector shell..... PADP-16V-1-S

Pins..... SPH-001T0.5L

4.5.4 P1 — 16-pin locking wire crimp interface (remote encoder)

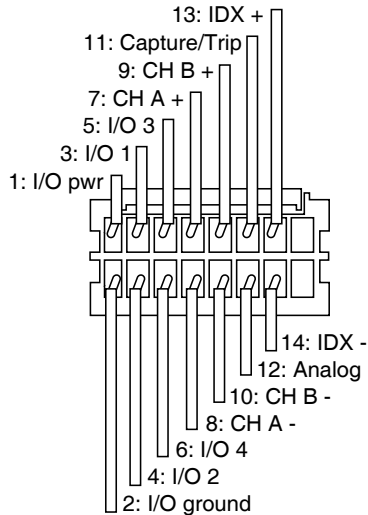

Pin Numbers	Signal	Prototype development cable wire colors (twisted pairs)
1	I/O power	Red
2	I/O ground	White
3	General purpose I/O 1	Orange
4	General purpose I/O 2	Black
5	General purpose I/O 3	Brown
6	General purpose I/O 4	Black
7	Channel A +	Yellow
8	Channel A -	Black
9	Channel B +	Blue
10	Channel B -	Black
11	Capture output/trip input	Green
12	Analog input	Black
13	Index +	White
14	Index -	Black

Table 4.12 I/O and remote encoder connections, 16-pin locking wire crimp

Connectivity accessories

Mating connector kitCK-10
(contains 5 connector shells and the appropriate quantity of pins to make 5 cables)

Prototype development cable (10'/3.0 m)..... PD16-1417-FL3

Manufacturer (JST) part numbers

Connector shell.....PADP-16V-1-S

Pins.....SPH-001T0.5L

4.6 Interfacing the motor

See part 1 of this document, section 5, for motor selection and interface configurations.

4.6.1 P1 — 4-pin locking wire crimp interface

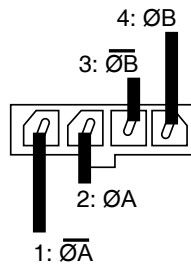

Connectivity accessories

Pin Numbers	Signal	Prototype development cable wire colors
1	Phase A return	White
2	Phase A output	Green
3	Phase B return	Black
4	Phase B output	Red

Table 4.13 Motor connections, 4-pin locking wire crimp

Manufacturer (Tyco) part numbers

Mating connector kit	CK-06 (contains 5 connector shells and the appropriate quantity of pins to make 5 cables)
Prototype development cable (3,0 m).....	PD04-MF17-FL3
Connector shell.....	Tyco 1445022-4
Pins.....	Tyco 1-794610-1

4.7 Connectivity accessory details

4.7.1 RS-422/485 communications converter cables

USB to 10-pin IDC connector P2
P/N: MD-CC400-001

Electrically isolated in-line USB to RS-422/485 converter pre-wired with mating connector to conveniently program and set configuration parameters

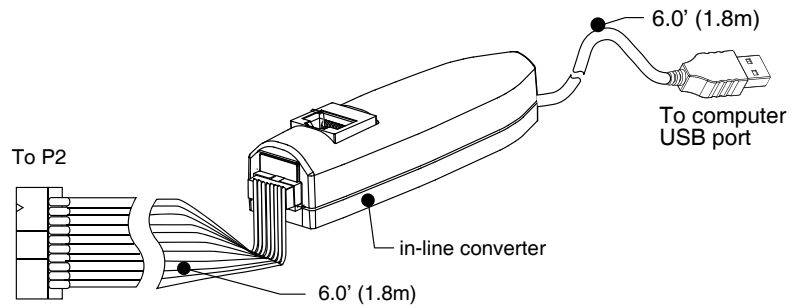

Figure 4.3 MD-CC400-000 communications converter cable

USB to 10-pin wire crimp connector P2
P/N: MD-CC402-001

Electrically isolated in-line USB to RS-422/485 converter pre-wired with mating connector to conveniently program and set configuration parameters

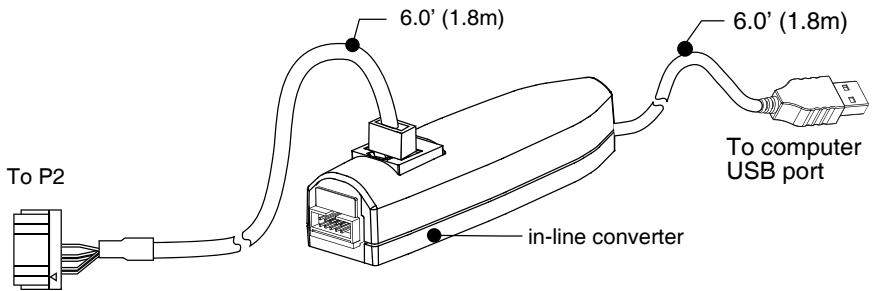

Figure 4.4 MD-CC402-001 communications converter cable

4.7.2 Prototype development cables

Flying leads to 10-pin wire crimp connector
 P2 -P/N: PD10-1434-FL3

Used in conjunction with the MD-CC402-001 communications converter cable to facilitate multi-drop RS-422/485 communications.

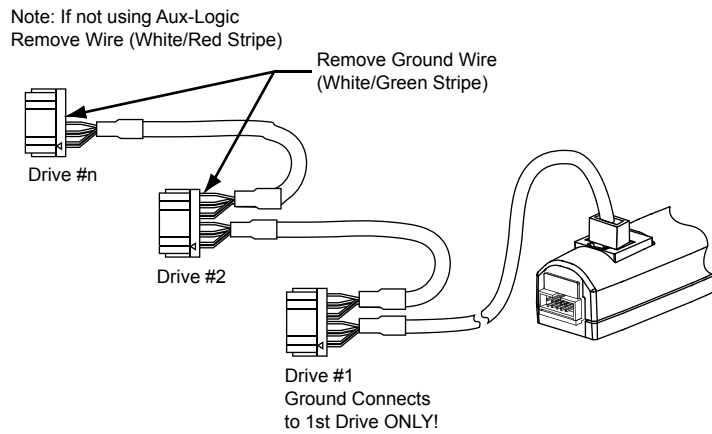
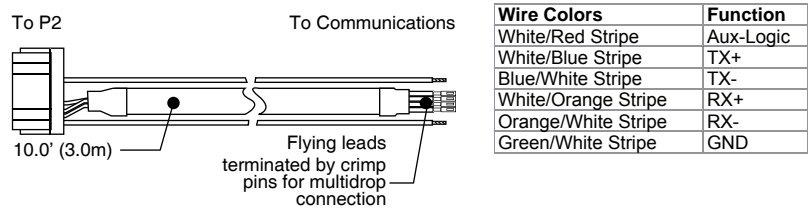

Figure 4.5 Multi-drop communications using the PD10-1434-FL3

Procedure

- 1) Remove ground wire (unless this is the first system MForce, green/white stripe)
- 2) Remove aux-logic (if not used, red/white stripe)
- 3) Connect pre-crimped flying leads as shown in Figure 4.6 below

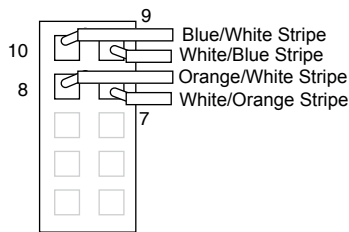

Figure 4.6 Wiring a second PD10-1434-FL3 into the 10-pin wire crimp connector.

Flying leads to 16-pin locking wire crimp connector P2 -P/N: PD16-1417-FL3

The PD16-1417-FL3 prototype development cable is used to rapidly interface the MForce to the users controller. This 10' (3.0 m) cable consists of a 16-pin locking wire crimp connector to plug directly into the MForce P1 connector with flying leads on the opposite end to interface to power, i/o and/or remote encoder.

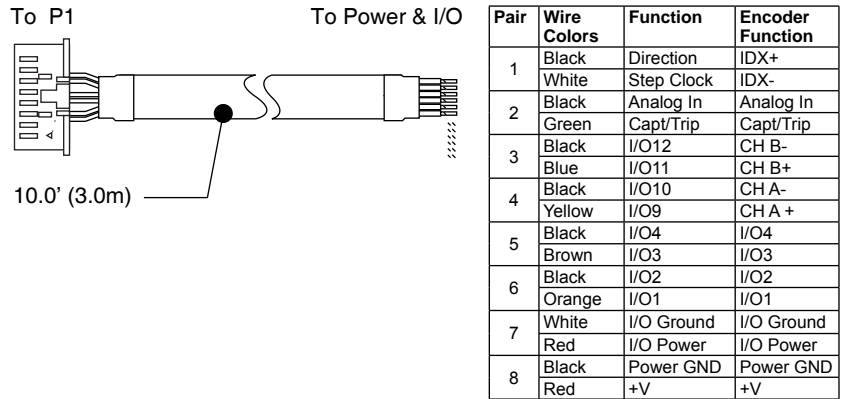

Figure 4.7 Prototype development cable PD16-1417-FL3

Prototype development cable PD04-MF17-FL3

Description: Pre-wired mating connector interfaces to an MForce 4-pin wire crimp connector, with flying leads other end, for quick test/development.

Function: Motor Interface.

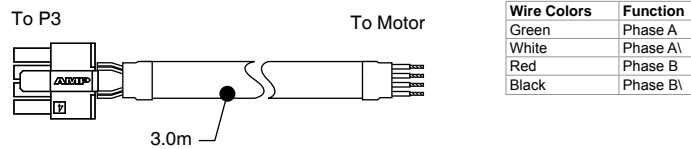

Figure 4.8 Prototype development cable PD04-MF17-FL3

4.7 Mating connector kits

Use to build your own cables. Kit contains 5 mating shells with pins. Cable not supplied. Manufacturer's crimp tool recommended.

Mates to connector:

P2 10-pin pressure-fit IDC	CK-01
P2 10-pin wire crimp.....	CK-02
P1 16-pin wire crimp.....	CK-10
P3 4-pin wire crimp.....	CK-06

This page intentionally left blank

Motion Control MForce PowerDrive



1. Introduction
2. Specifications
3. Mounting Recommendations
4. Interface and Connectivity

This page intentionally left blank

Table of Contents

1	Introduction.....	1-1
1.1	MForce PowerDrive unit overview.....	1-1
1.2	Product identification.....	1-2
1.3	Documentation reference.....	1-2
1.4	Product software.....	1-2
2	Specifications	2-1
2.1	Mechanical specifications.....	2-1
2.2	General specifications.....	2-2
2.2.1	Electrical specifications.....	2-2
2.2.2	Standard I/O specifications (plus).....	2-2
2.2.3	Expanded I/O specifications (Plus ² expanded features).....	2-3
2.2.4	Communications specifications.....	2-4
2.2.5	Thermal specifications.....	2-4
2.2.6	Motion specifications.....	2-5
2.2.7	Software specifications.....	2-5
2.2.8	Performance curves.....	2-6
2.3	Connectivity specifications/pin assignments — Communications.....	2-7
2.3.1	RS-422/485 communications.....	2-7
2.3.2	CANopen communications option.....	2-8
2.4	Connectivity specifications/pin assignments - Power and ... I/O.....	2-9
2.4.1	Power and I/O - standard I/O.....	2-9
2.4.2	DC motor power.....	2-10
2.4.3	I/O - expanded I/O (Plus ² expanded features).....	2-10
2.4.4	I/O - remote encoder (Plus ²).....	2-11
2.4	Connectivity specifications/pin assignments - Motor.....	2-12
2.5	Options.....	2-13
2.6	Connectivity.....	2-13
3	Mounting and connection recommendations.....	3-1
3.1	Mounting.....	3-2
3.2	Layout and interface guidelines.....	3-3
3.2.1	Rules of wiring.....	3-3
3.2.2	Rules of shielding.....	3-3
3.3	Recommended wiring.....	3-4
3.3.1	Recommended mating connectors and pins.....	3-4
4	Connection and interface	4-1
4.1	Connector orientation.....	4-2
4.2	Interfacing RS422-485 communications.....	4-3
4.2.1	P2 — 10-pin pressure-fit IDC style connector ...	4-3
4.2.2	P2 — 10-pin friction lock wire crimp.....	4-4
4.3	Interfacing CANopen communications.....	4-4
4.3.1	P2 — 9-pin d-sub connector (female).....	4-4
4.4	Interfacing DC power.....	4-5
4.4.1	Recommended power supply characteristics.....	4-5
4.4.2	Recommended wire gauge.....	4-5
4.4.3	P1 — 12' (30.5 cm) flying leads interface.....	4-6
4.4.4	P3 — 2-pin locking wire crimp interface.....	4-6

- 4.4.5 Power Interface using Drive Protection Module
DPM75.....4-6
- 4.5 Interfacing I/O.....4-7
 - 4.5.1 P1 — 12' (30.5 cm) flying leads interface4-7
 - 4.5.2 P1 — 14-pin locking wire crimp interface
(expanded I/O).....4-8
 - 4.5.3 P1 — 20-pin locking wire crimp interface (remote .
encoder).....4-9
- 4.6 Interfacing the motor4-10
 - 4.6.1 P1 — 4-pin locking wire crimp interface4-10
- 4.7 Connectivity accessory details4-11
 - 4.7.1 Communications converter cables.....4-11
 - 4.7.2 Prototype development cables4-12
- 4.8 Mating connector kits4-14

List of Figures

- Figure 1.1 Standard product options 1-2
- Figure 2.1 Standard and Expanded features mechanical specifications 2-1
- Figure 2.2 Speed-torque curves2-6
- Figure 3.1 MForce PowerDrive mounting3-2
- Figure 4.1 Connector orientation4-2
- Figure 4.2 DPM75 Drive Protection Module4-6
- Figure 4.3 MD-CC400-000 communications converter cable.....4-11
- Figure 4.4 MD-CC402-001 communications converter cable.....4-11
- Figure 4.3 Multi-drop communications using the PD10-1434-FL34-12
- Figure 4.4 Wiring a second PD10-1434-FL3 into the 10-pin wire crimp
connector. 4-12
- Figure 4.5 Prototype development cable PD14-2334-FL34-13
- Figure 4.6 Prototype development cable PD20-3400-FL34-13
- Figure 4.7 Prototype development cable PD02-3400-FL34-14
- Figure 4.8 Prototype development cablePD04-3400-FL34-14

List of Tables

Table 2.1	Electrical specifications	2-2
Table 2.2	I/O specifications	2-2
Table 2.3	Expanded I/O specifications.....	2-3
Table 2.4	Communications specifications.....	2-4
Table 2.5	Thermal specifications.....	2-4
Table 2.6	Motion specifications	2-5
Table 2.7	Software specifications.....	2-5
Table 2.9	P2 communications, 10-pin locking wire crimp	2-7
Table 2.10	P2 communications, 10-pin pressure fit IDC/SAMTEC	2-7
Table 2.11	CANopen communications, P2: 9-pin D-sub female (DB-9F).....	2-8
Table 2.12	Power and I/O interface - 12" (308.8mm) flying leads.....	2-9
Table 2.13	P3 DC power, 2-pin locking wire crimp	2-10
Table 2.14	P1 Expanded I/O, 14-pin locking wire crimp	2-10
Table 2.15	I/O and remote encoder interface - 20-pin locking wire crimp.....	2-11
Table 2.7	P4 motor, 4-pin locking wire crimp	2-12
Table 4.1	Communications connections, P2 - 10-pin IDC.....	4-3
Table 4.2	P2 communications, 10-pin locking wire crimp	4-4
Table 4.3	CANopen communications, P2: 9-pin D-sub female (DB-9F).....	4-4
Table 4.4	Recommended power supply specifications	4-5
Table 4.51	Recommended power supply wire gauge	4-5
Table 4.6	Power and ground connections, flying leads.....	4-6
Table 4.7	Power and ground connections, 12-pin locking wire crimp ...	4-6
Table 4.8	I/O connections, flying leads	4-7
Table 4.9	I/O connections, 16-pin locking wire crimp.....	4-8
Table 4.20	I/O and remote encoder connections, 16-pin locking wire crimp.....	4-9
Table 4.11	Motor connections, 4-pin locking wire crimp	4-10

Page intentionally left blank

1 Introduction

The **Motion Control MForce PowerDrive** offers system designers a cost effective, full featured programmable motion controller integrated with a +12 up to +75 VDC* microstepping driver.

1.1 MForce PowerDrive unit overview

The unsurpassed smoothness and performance delivered by the Motion Control MForce PowerDrive are achieved through advanced 2nd generation current control. By applying innovative techniques to control current flow through the motor, resonance is significantly dampened over the entire speed range and audible noise is reduced.

The MForce PowerDrive accepts a broad input voltage range from +12 up to +75 VDC*, delivering enhanced performance and speed. Oversized input capacitors are used to minimize power line surges, reducing problems that can occur with long cable runs and multiple drive systems. An extended operating range of -40° to $+85^{\circ}\text{C}$ provides long life, trouble free service in demanding environments.

Standard features of all Motion Control MForce PowerDrive include four +5 to +24 volt general purpose I/O lines, one 10 bit analog input, 0 to 5MHz step clock rate, 20 microstep resolutions up to 51,200 steps per revolution, and full featured easy-to-program instruction set.

Expanded features of MForce PowerDrive versions include up to eight +5 to +24 volt general purpose I/O lines and the capability of electronic gearing by following a rotary or linear axis at an electronically controlled ratio, or an output clock can be generated fixed to the internal step clock.

For an expanded choice of line counts and resolutions with MForce PowerDrive versions only, closed loop control is available with an interface to a remotely mounted user-supplied external encoder.

The MForce communicates over RS-422/485 which allows for point-to-point or multiple unit configurations utilizing one communication port. Addressing and hardware support up to 62 uniquely addressed units communicating over a single line. Baud rate is selectable from 4.8 to 115.2kbps.

Optional communication protocols include CANopen. The CAN bus is 2.0B active (11 and/or 29 bit) and is capable of all standard frequencies from 10kHz to 1MHz. CANopen features include node guarding, heartbeat producer, SDOs and PDOs. Highlights include variable PDO mapping and extended node identifier.

Numerous connector styles give you choices for the best fit and features. Select from 12.0" (30.5cm) flying leads, pluggable terminal strip, locking wire crimp connectors, and M12/M23 circular connectors on IP65 sealed versions.

MForce connectivity has never been easier with options ranging from all-inclusive QuickStart Kits to individual interfacing cables and mating connector kits to build your own cables.

The MForce PowerDrive is a compact, powerful and cost effective motion control solution that will reduce system cost, design and assembly time for a large range of brushless step motor applications.

1.2 Product identification

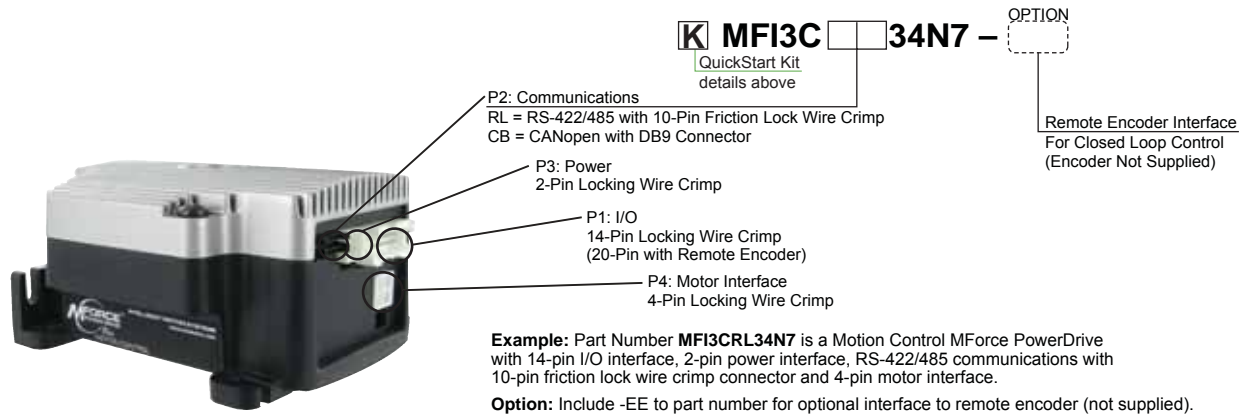

Figure 1.1 Standard product options

1.3 Documentation reference

The following User's manuals are available for the MForce PowerDrive:

- Product manuals, describes the technical data, installation, configuration and programming of the product.
- Quick Reference, describes the basic wiring, connection and use of this product. The quick reference is shipped in printed form with the product.

This documentation is also available for download from the IMS web site at www.novantaims.com

1.4 Product software

The Motion Control MForce PowerDrive integrated motor and driver may be programmed using any standard ASCII txt editor and ANSI terminal emulated. The recommended environment is the Novanta IMS Terminal Interface, which is a combined terminal/program editor tailored for use with motion control products. This free software may be downloaded from <https://novantaims.com/downloads/>.

Installation and usages instructions are to be found in the MCode Programming Manual, which is correlated to this document.

2 Specifications

2.1 Mechanical specifications

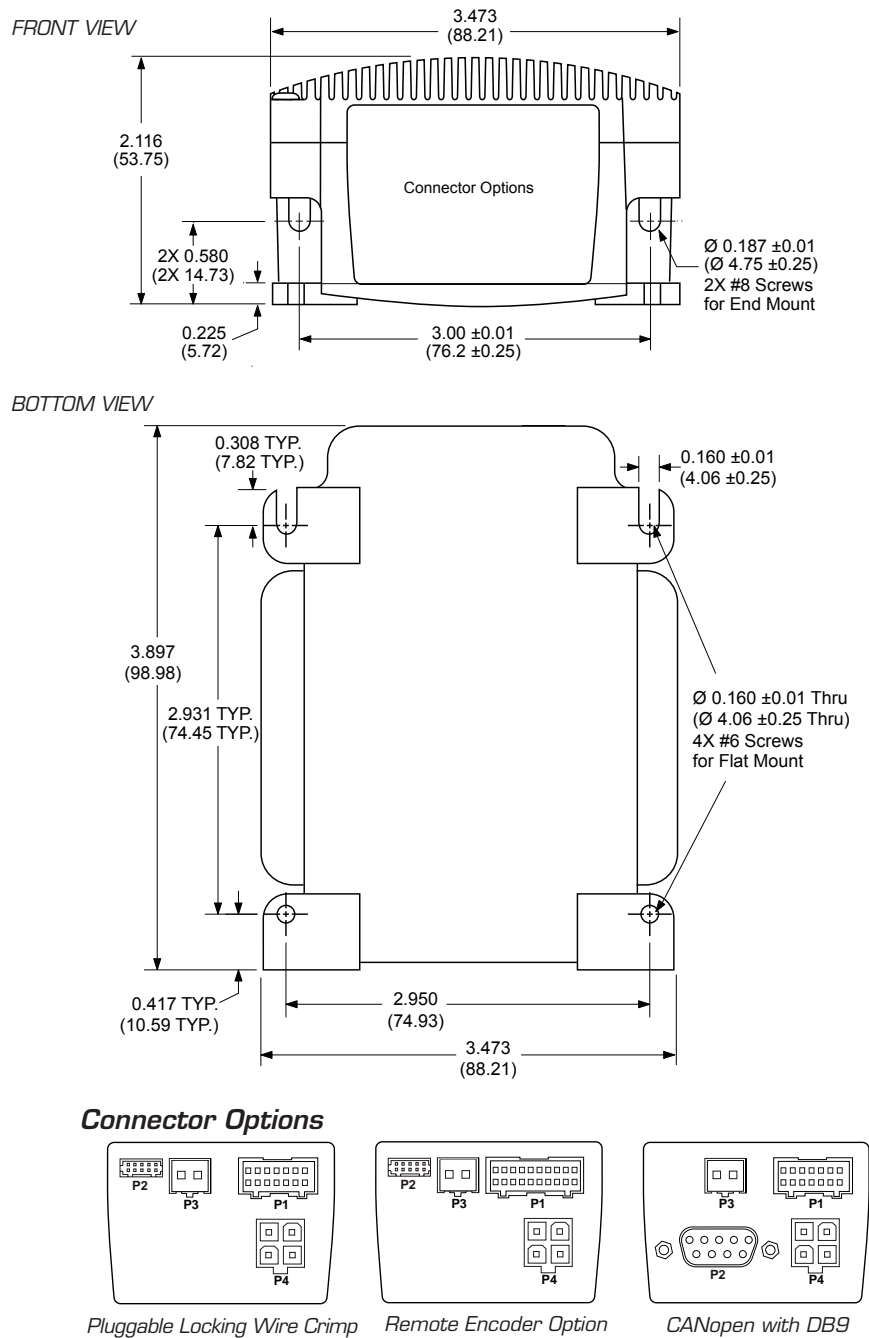

Figure 2.1 Standard and Expanded features mechanical specifications

2.2 General specifications

2.2.1 Electrical specifications

	Condition	Min	Typ	Max	Unit
Input voltage range	—	+12	—	+75	VDC
Max power supply current	—	—	—	4.0*	A
Output Current	RMS	—	—	5.0	A
	Peak	—	—	7.0	A

*per MForce PowerDrive, Actual current depends on voltage and load.

** Maintains power to control and feedback circuits [only] when input voltage is removed

Table 2.1 Electrical specifications

2.2.2 Standard I/O specifications (plus)

	Condition	Min	Typ	Max	Unit
General Purpose I/O - Number and Type					
I/O Points 1-4	—	4 I/O points configurable as sinking or sourcing inputs or sinking outputs			
General Purpose I/O - Electrical					
Inputs	—	TTL	—	+24	VDC
Sinking Outputs	—	—	—	+24	VDC
Output Sink Current	One channel	—	—	600	mA
Logic Threshold	Logic 0	—	—	< 0.8	VDC
	Logic 1	—	—	> 2.2	VDC
Protection	Sinking	Over temp, short circuit			
	Sourcing	Transient Over Voltage, Inductive Clamp			
Analog Input					
Resolution	—				
Range	Voltage Mode	0 to +5 VDC, 0 to +10 VDC			
	Current Mode	4 to 20 mA, 0 to 20mA			
Clock I/O					
Types	—	Step/Direction, Up/Down, Quadrature			
Logic Threshold	—	+5 VDC TTL Input, TTL Output (with 2 kΩ Load to Ground)			
Trip Output/Capture Input					
Logic Threshold	—	+5 VDC TTL Input, TTL Output (with 2 kΩ Load to Ground)			

Table 2.2 I/O specifications

2.2.3 Expanded I/O specifications (Plus² expanded features)

	Condition	Min	Typ	Max	Unit
General Purpose I/O - Number and Type					
I/O Points 1-8	—	8 I/O points (4 if configured for remote encoder) configurable as sinking or sourcing inputs or outputs			
General Purpose I/O - Electrical					
Inputs	Sinking or Sourcing	TTL	—	+24	VDC
Outputs	Sinking	—	—	+24	VDC
	Sourcing	+12	—	+24	VDC
Output Sink Current	One channel	—	—	600	mA
Motion I/O					
Electronic gearing	Range	0.001	—	2.000	
	Resolution	—	—	32	bit
	Threshold	—	—	TTL	VDC
	Filter range	50 nS to 12.9 μS (10 MHz to 38.8 kHz)			
	Secondary clock out ratio	1:1			
High speed position capture	Filter range	50 nS to 12.9 μS (10 MHz to 38.8 kHz)			
	Resolution	—	—	32	bit
High speed trip output	Speed	—	—	150	nS
	Resolution	—	—	32	bit
	Threshold	—	—	TTL	VDC
Optional remote encoder (closed loop)*					
Type	User supplied differential encoder				
Steps per revolution	See motion specifications table				
Resolution	User defined . Note: microsteps/rev = 2X the encoder counts/rev minimum.				

*Remote encoder inputs replace I/O points 4-8 and step and direction I/O

Table 2.3 Expanded I/O specifications

2.2.4 Communications specifications

	Condition	Min	Typ	Max	Unit
RS-422/485 (standard)					
BAUD rate	—	4.8		115.2	kbps
CANopen (optional)					
Type					2.0B active
BAUD rate	—	10 kHz	—	1 MHz	—
Application layer	Version 3.0				DS-301
Device profile	Version 2.0				DSP-402
ID	—				11 or 29 bit
Isolation	—				Galvanic

Table 2.4 Communications specifications

2.2.5 Thermal specifications

		Min	Typ	Max	Unit
Heat sink temperature	non-condensing humidity	-40	—	+85	°C
Motor temperature	non-condensing humidity	-40	—	+100	°C

Table 2.5 Thermal specifications

2.2.6 Motion specifications

Microstep Resolution - Open Loop									
Number of microstep resolutions									20
Available microsteps per revolution									
200	400	800	1000	1600	2000	3200	5000	6400	10000
12800	20000	25000	25600	40000	50000	51200	36000 ¹	21600 ²	25400 ³
1=0.01 deg/μstep 2=1 arc minute/μstep *3=0.001 mm/μstep * 1" per revolution lead screw									
Counters									
Counter 1 (C1) Type									Position
Counter 2 (C2) Type									Encoder
Resolution									32 bit
Maximum Edge Rate									5 MHz
Velocity									
Range									±5,000,000 Steps/Sec.
Resolution									0.5961 Steps/Sec.
Acceleration/Deceleration									
Range									1.5 x 10 ⁹ Steps/Sec. ²
Resolution									90.9 Steps/Sec. ²

Table 2.6 Motion specifications

2.2.7 Software specifications

Program Storage Type/Size	Flash/6384 Bytes
User Registers	(4) 32 Bit
User Program Labels and Variables	192
Math, Logic and Conditional Functions	+, -, x, ÷, <, >, =, ≤, ≥, AND, OR, XOR, NOT
Branch Functions	Branch and Call (Conditional)
Party Mode Addresses	62
Encoder Functions	Stall Detect, Position Maintenance, Find Index
Predefined I/O Functions	
Input Functions	Home, Limit+, Limit -, Go, Stop, Pause, Jog+, Jog-, Analog Input
Output Functions	Moving, Fault, Stall, Velocity Changing
Trip Functions	Trip on Input, Trip on Position, Trip on Time, Trip Capture

Table 2.7 Software specifications

2.2.8 Performance curves

Motor performance curves were generated using stock motors sold by Novanta IMS. For performance information specific to the motor you are using see the manufacturer documentation.

NEMA 23 — 2.4 Amps RMS

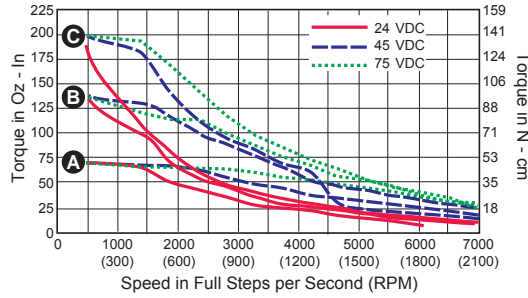

NEMA 23 — 3.0 Amps RMS

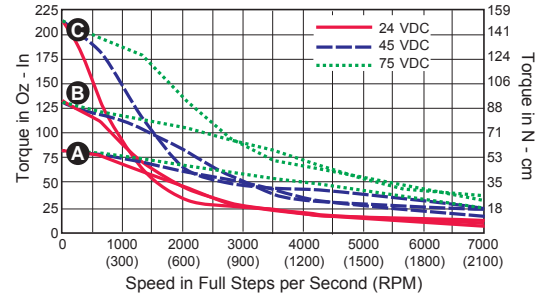

NEMA 23 — 6.0 Amps RMS

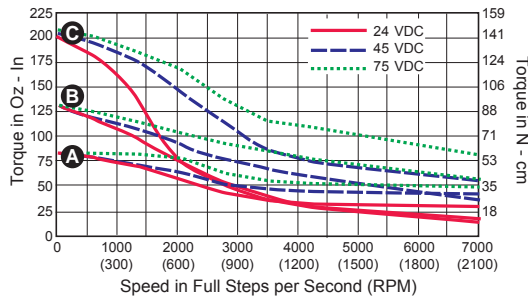

NEMA 34 — 6.3 Amps RMS

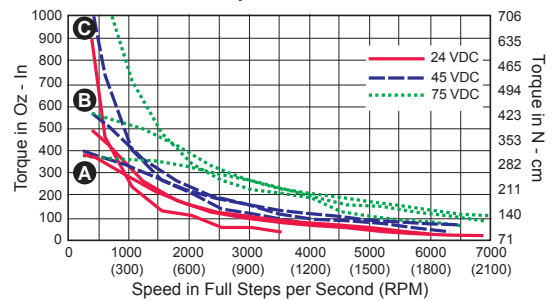

A Single Stack **B** Double Stack **C** Triple Stack

Figure 2.2 Speed-torque curves

2.3 Connectivity specifications/pin assignments — Communications

2.3.1 RS-422/485 communications

10-pin friction lock wire crimp (only available on pluggable connector versions)

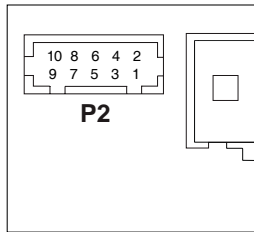

Connectivity Options
 USB to RS-422/485
 Converter:
 MD-CC402-001

Mating connector kit:
 CK-02

Mfg P/N:
 Shell
 Hirose DF11-10DS-2C

Pins
 Hirose: DF11-2428SC

Pin #	Function	Description
1	TX +	Transmit plus
2	Comm GND	Communications ground only. Do not ground aux-logic to this pin.
3	RX -	Receive minus
4	TX -	Transmit minus
5	Aux-Logic	Auxiliary logic maintains power to the logic circuitry in the absence of motor power. +12 to +24 VDC input
6	RX +	Receive plus
7	RX +	Receive plus
8	RX -	Receive minus
9	TX +	Transmit plus
10	TX -	Transmit minus

Table 2.9 P2 communications, 10-pin locking wire crimp

10-pin press-fit (IDC style) Only available on flying leads versions

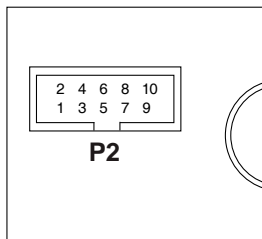

Connectivity Options
 USB to RS-422/485
 Converter:
 MD-CC400-001

Mating connector kit:
 CK-01

Mfg P/N:
 Shell
 SAMTEC: TCSD-05-01-N

Ribbon cable
 Tyco: 1-57051-9

Pin #	Function	Description
1	TX +	Transmit plus
2	TX -	Transmit minus
3	RX +	Receive plus
4	RX -	Receive minus
5	Aux-Logic	Auxiliary logic maintains power to the logic circuitry in the absence of motor power. +12 to +24 VDC input
6	RX +	Receive plus
7	RX -	Receive minus
8	TX -	Transmit minus
9	TX +	Transmit plus
10	Comm GND	Communications ground only. Do not ground aux-logic to this pin.

Table 2.10 P2 communications, 10-pin pressure fit IDC/SAMTEC

2.3.2 CANopen communications option

9-pin D-sub female (DB-9F)

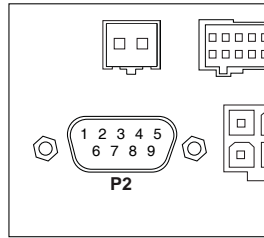

Connectivity Options
 USB to CANopen converter:
 MD-CC500-000

Pin #	Function	Description
1	N/C	Not connected
2	CAN low	CAN_L bus line (low dominant)
3	CAN -V	CAN communications ground
4	N/C	Not connected
5	Shield	Optional CAN shield
6	CAN -V	Optional ground
7	CAN high	CAN_H bus line (high dominant)
8	N/C	Not connected
9	CAN +V	+7 to +30 VDC power supply

Table 2.11 CANopen communications, P2: 9-pin D-sub female (DB-9F)

2.4 Connectivity specifications/pin assignments - Power and I/O

2.4.1 Power and I/O - standard I/O

12" (304.8 mm) flying leads

Wire Color	Function	Description
White/yellow	I/O 1	General purpose I/O point 1
White/orange	I/O 2	General purpose I/O point 2
White/violet	I/O 3	General purpose I/O point 3
White/blue	I/O 4	General purpose I/O point 4
Green	Analog input	0 to +5 VDC, 0 to +10 VDC, 4 to 20 mA, 0 to 20 mA
Black	GND	Power and auxiliary ground
Red	+V	Motor power

Table 2.12 Power and I/O interface - 12" (308.8.mm) flying leads

2.4.2 DC motor power

2-pin friction lock wire crimp

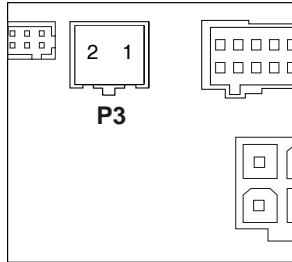

Pin #	Function	Description
1	+V	+12 to +60 VDC motor power
2	Ground	Power supply return (ground)

Table 2.13 P3 DC power, 2-pin locking wire crimp

Connectivity Options
 Prototype development cable PD-02-3400-FL3

 Mating connector kit: CK-05

 Mfg P/N:
 Shell
 Molex 751067-0200

 Pins
 Molex 750217-9101

2.4.3 I/O - expanded I/O (Plus² expanded features)

14-pin locking wire crimp

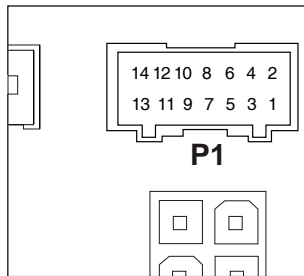

Pin #	Function	Description
1	I/O power	I/O Power, used with sourcing inputs or outputs
2	I/O GND	Non-isolated I/O Ground. Common with Power Ground
3	I/O 1	0 to +24 VDC Programmable I/O Point 1
4	I/O 2	0 to +24 VDC Programmable I/O Point 2
5	I/O 3	0 to +24 VDC Programmable I/O Point 3
6	I/O 4	0 to +24 VDC Programmable I/O Point 4
7	I/O 9	0 to +24 VDC Programmable I/O Point 9
8	I/O 10	0 to +24 VDC Programmable I/O Point 10
9	I/O 11	0 to +24 VDC Programmable I/O Point 11
10	I/O 12	0 to +24 VDC Programmable I/O Point 12
11	Capture/trip I/O	High Speed Capture Input or Trip Output. +5 VDC Logic Level
12	Analog in	0 to 10 V / 4 to 20 mA / 0 to 20 mA Analog Input
13	Step/clock I/O	Step clock i/o. Can also be configured as quadrature or clock up/down. +5 VDC logic level.
14	Direction/clock I/O	Direction i/o. Can also be configured as quadrature or clock up/down. +5 VDC logic level.

Table 2.147 P1 Expanded I/O, 14-pin locking wire crimp

Connectivity Options
 Prototype development cable:: PD14-2334-FL3

 Mating connector kit: CK-09

 Mfg P/N:
 Shell
 JST PADP-14V-1-S

 Pins
 JST SPH-001T0.5L

Revision R060923

2.4.4 I/O - remote encoder (Plus²)

20-pin locking wire crimp

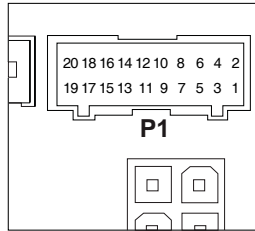

Connectivity Options
 Prototype development cable::
PD20-3400-FL3

Mating connector kit:
CK-11

Mfg P/N:
 Shell
JST PADP-20V-1-S

Pins
JST SPH-001T0.5L

Pin #	Function	Description
1	I/O power	I/O Power, used with sourcing inputs or outputs
2	I/O GND	Non-isolated I/O Ground. Common with Power Ground
3	I/O 1	0 to +24 VDC Programmable I/O Point 1
4	I/O 2	0 to +24 VDC Programmable I/O Point 2
5	I/O 3	0 to +24 VDC Programmable I/O Point 3
6	I/O 4	0 to +24 VDC Programmable I/O Point 4
7	I/O 9	0 to +24 VDC Programmable I/O Point 9
8	I/O 10	0 to +24 VDC Programmable I/O Point 10
9	I/O 11	0 to +24 VDC Programmable I/O Point 11
10	I/O 12	0 to +24 VDC Programmable I/O Point 12
11	Capture/trip I/O	High Speed Capture Input or Trip Output. +5 VDC Logic Level
12	Analog in	0 to 10 V / 4 to 20 mA / 0 to 20 mA Analog Input
13	Step/clock I/O	Step clock i/o. Can also be configured as quadrature or clock up/down. +5 VDC logic level.
14	Direction/clock I/O	Direction i/o. Can also be configured as quadrature or clock up/down. +5 VDC logic level.
15	CH A+	Channel A+ encoder input. +5 VDC logic level
16	CH A-	Channel A- encoder input. +5 VDC logic level
17	CH B+	Channel B+ encoder input. +5 VDC logic level
18	CH B-	Channel B- encoder input. +5 VDC logic level
19	IDX+	Index mark + encoder input. +5 VDC logic level
20	IDX-	Index mark - encoder input. +5 VDC logic level

Table 2.15 I/O and remote encoder interface - 20-pin locking wire crimp

2.4 Connectivity specifications/pin assignments - Motor

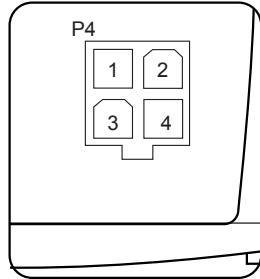

Pin #	Function	Description
1	ØA	Phase A output
2	ØA	Phase A return
3	ØB	Phase B output
4	ØB	Phase B return

Table 2.7 P4 motor, 4-pin locking wire crimp

Connectivity Options
 Prototype development cable
PD02-3400-FL3

Mating connector kit:
CK-07

Mfg P/N:
 Shell
Molex 39-01-2045
 Pins
Molex 44476-3112

2.5 Options

Drive Protection Module The function of the DPM75 Drive Protection Module is to limit the surge current and voltage to a safe level when DC input power is switched on and off to the MForce).

2.6 Connectivity

QuickStart kit For rapid design verification, all-inclusive QuickStart Kits have communication converter, prototype development cable(s), instructions and CD for MForce initial functional setup and system testing.

Communication Converters Electrically isolated, in-line converters pre-wired with mating connectors to conveniently set/program communication parameters for a single MForce product via a PC's USB port. Length 12.0' (3.6m).

Mates to connector:

P2 10-pin pressure-fit IDC MD-CC400-001

P2 10-pin wire crimp MD-CC402-001

P2 9-pin DSub (CANopen) MD-CC500-000

Prototype Development Cables Speed test/development with pre-wired mating connectors that have flying leads other end. Length 10.0' (3.0m).

Mates to connector:

P2 10-pin wire crimp PD10-1434-FL3

P1 20-pin wire crimp PD20-3400-FL3

3400P1 14-pin wire crimp PD14-2334-FL3

P3 2-pin wire crimp PD02-3400-FL3

Mating Connector Kits Use to build your own cables. Kit contains 5 mating shells with pins. Cable not supplied. Manufacturer's crimp tool recommended.

Mates to connector:

P2 10-pin pressure-fit IDC CK-01

P2 10-pin wire crimp CK-02

P1 14-pin wire crimp CK-09

P1 20-pin wire crimp CK-11

P3 2-pin wire crimp CK-05

Page intentionally left blank

3 Mounting and connection recommendations

⚠ DANGER**EXPOSED SIGNALS**

Hazardous voltage levels may be present if using an open frame power supply to power the product.

Failure to follow these instructions will result in death or serious injury.

⚠ CAUTION**SWITCHING DC POWER/HOT PLUGGING**

Do not connect or disconnect power, logic, or communications while the device is in a powered state.

Remove DC power by powering down at the AC side of the DC power supply.

Failure to follow these instructions can result in equipment damage.

⚠ CAUTION**LEAD RESTRAINT**

Some MForce mounting configurations require that the drive move along a screw. Ensure that all cabling is properly restrained to provide strain relief on connection points..

Failure to follow these instructions can result in equipment damage.

⚠ CAUTION**THERMAL MANAGEMENT**

Do not remove the thermal pad attached to the mounting surface of the MForce PowerDrive. It is essential to maintaining a safe driver temperature at full current..

Failure to follow these instructions can result in equipment damage.

3.1 Mounting

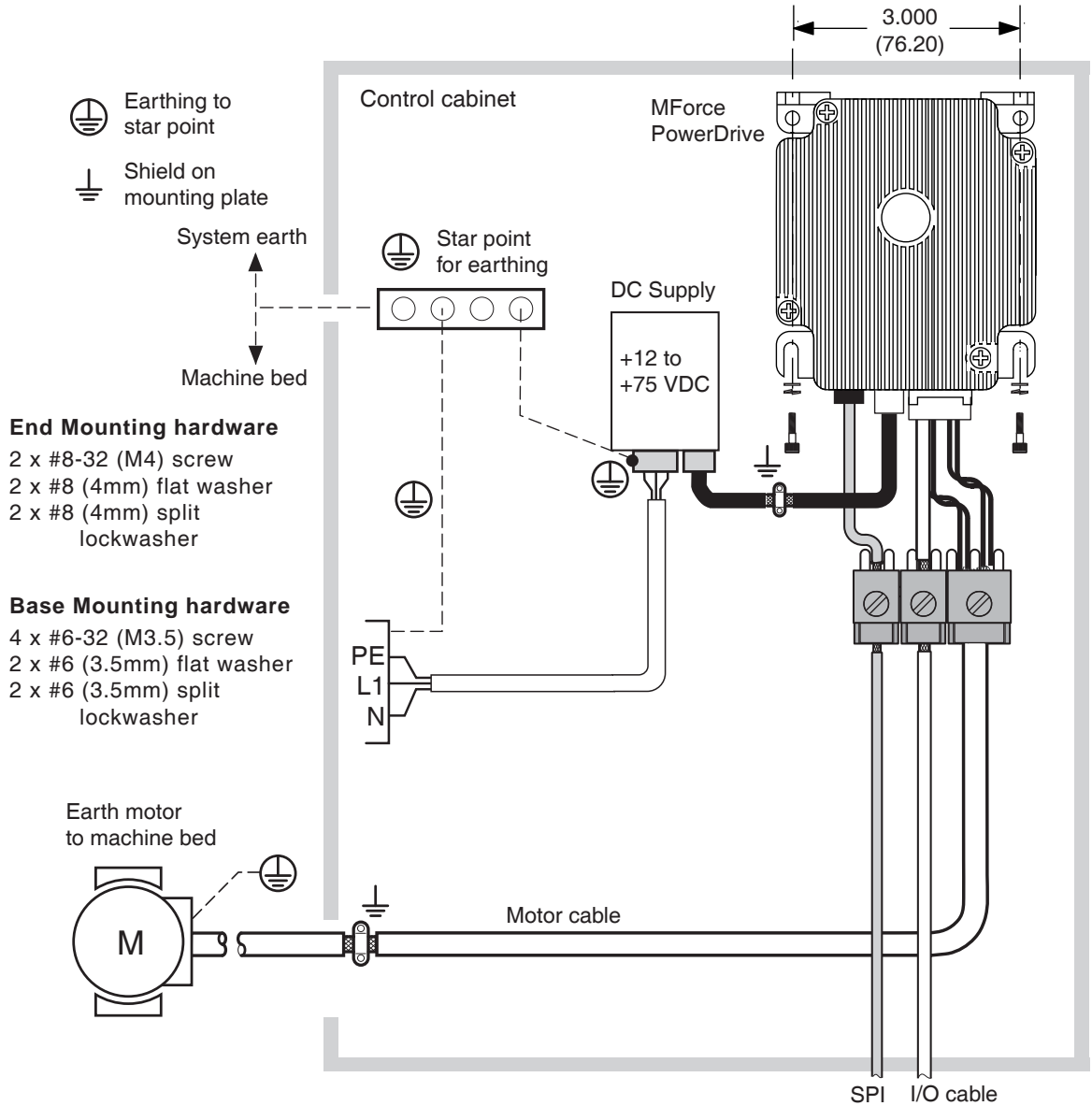

Figure 3.1 MForce PowerDrive mounting

3.2 Layout and interface guidelines

Logic level cables must not run parallel to power cables. Power cables will introduce noise into the logic level cables and make your system unreliable.

Logic level cables must be shielded to reduce the chance of EMI induced noise. The shield needs to be grounded at the signal source to earth. The other end of the shield must not be tied to anything, but allowed to float. This allows the shield to act as a drain.

Power supply leads to the MForce PowerDrive need to be twisted. If more than one driver is to be connected to the same power supply, run separate power and ground leads from the supply to each driver.

3.2.1 Rules of wiring

- Power supply and motor wiring should be shielded twisted pairs, and run separately from signal-carrying wires.
- A minimum of one twist per inch is recommended.
- Motor wiring should be shielded twisted pairs using 20 gauge, or for distances of more than 2 m, 18 gauge or better.
- Power ground return should be as short as possible to established ground.
- Power supply wiring should be shielded twisted pairs of 18 gauge for less than 4 amps DC and 16 gauge for more than 4 amps DC.

3.2.2 Rules of shielding

- The shield must be tied to zero-signal reference potential. It is necessary that the signal be earthed or grounded, for the shield to become earthed or grounded. Earthing or grounding the shield is not effective if the signal is not earthed or grounded.
- Do not assume that Earth ground is a true Earth ground. Depending on the distance from the main power cabinet, it may be necessary to sink a ground rod at the critical location.
- The shield must be connected so that shield currents drain to signal-earth connections.
- The number of separate shields required in a system is equal to the number of independent signals being processed plus one for each power entrance.
- The shield should be tied to a single point to prevent ground loops.
- A second shield can be used over the primary shield; however, the second shield is tied to ground at both ends.

3.3 Recommended wiring

The following wiring/cabling is recommended for use with the MForce PowerDrive:

Logic Wiring..... 22 AWG
 Wire Strip Length..... 0.25" (6.0 mm)
 Power, GroundSee Part 1 Section 3 of this document

3.3.1 Recommended mating connectors and pins

Communications

Press-Fit IDC - P2 (MForce PowerDrive Only)

10-Pin IDC Samtec: TCSD-05-01-N
 Ribbon Cable Tyco: 1-57051-9

Friction Lock Wire Crimp - P2

10-pin Friction Lock (MDI34Plus2) Hirose DF11-10DS-2C
 Crimp Contact for 10-pin Friction Lock (22 AWG) DF11-22SC
 Crimp Contact for 10-pin Friction Lock (24 - 28 AWG)DF11-2428SC
 Crimp Contact for 10-pin Friction Lock (30 AWG) DF11-30SC

I/O, and Power

The following mating connectors are recommended:

Manufacturer PNs

14-pin Locking Wire Crimp Connector Shell JST PN PADP-14V-1-S
 Crimp Pins JST PN SPH-001T-P0.5L
 20-pin Locking Wire Crimp Shell JST PN PADP-20V-1-S
 Crimp Pins JST PN SPH-001T-P0.5L
 2-pin Locking Wire Crimp Connector Shell..... Molex 51067-0200
 Crimp Pins Molex 50217-9101 Brass

Motor

4-pin locking wire crimp connector shell..... Molex 39-01-2045
 Crimp pins Molex 44476-3112

4 Connection and interface

 DANGER**EXPOSED SIGNALS**

Hazardous voltage levels may be present if using an open frame power supply to power the product.

Failure to follow these instructions will result in death or serious injury.

 CAUTION**SWITCHING DC POWER/HOT PLUGGING**

Do not connect or disconnect power, logic, or communications while the device is in a powered state.

Remove DC power by powering down at the AC side of the DC power supply.

Failure to follow these instructions can result in equipment damage.

4.1 Connector orientation

The illustration below shows the connector positions and orientation with regard to the location of pin 1.

All connector drawings in this section will show this orientation.

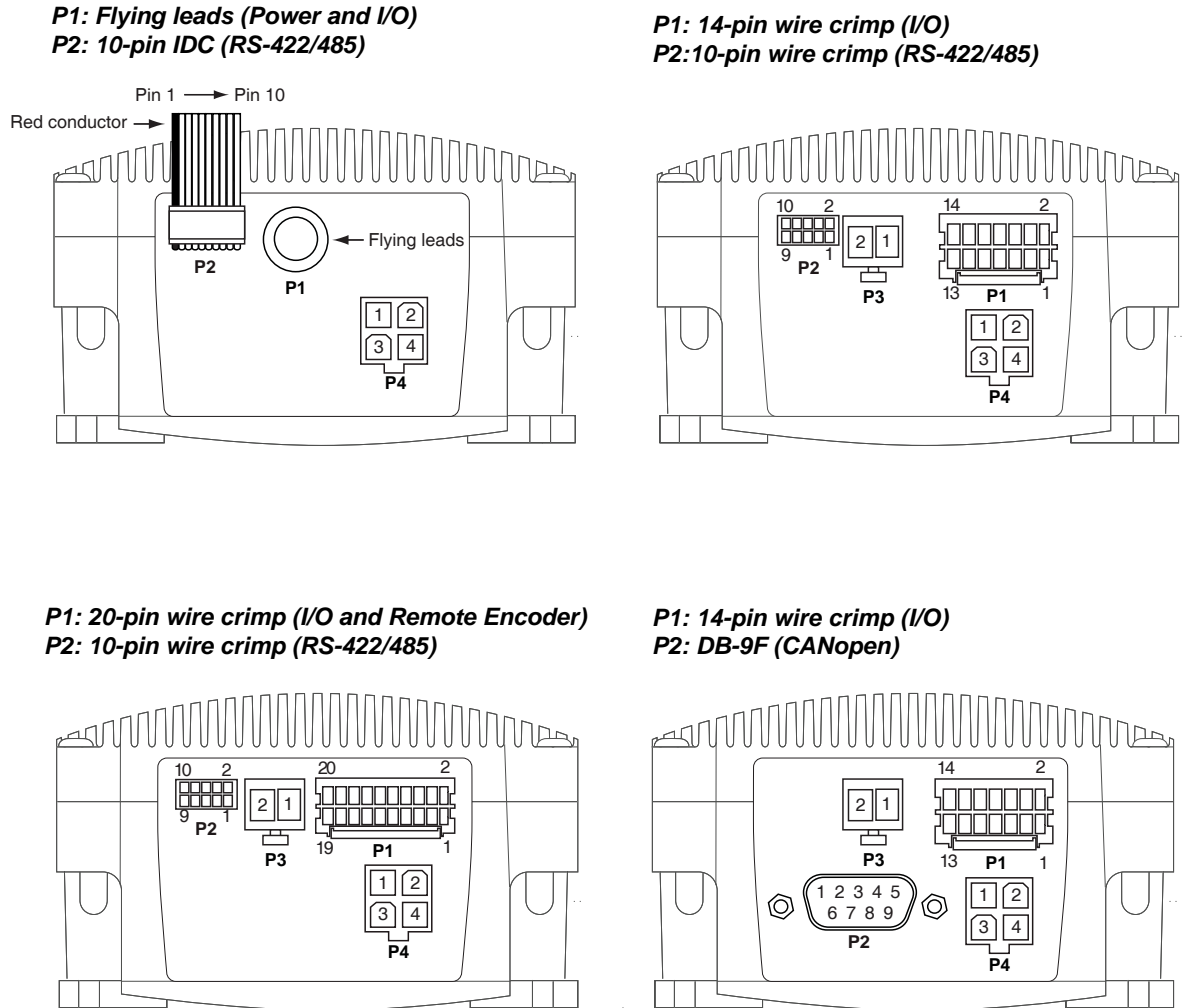

Figure 4.1 Connector orientation

4.2 Interfacing RS422-485 communications

For general RS422/485 single and party mode communications practices please see Part 1 Section 5 of this document.

⚠ CAUTION
COMMUNICATIONS GROUND LOOPS
To avoid ground loops in the system only connect communications ground to the first MForce in the system. Do not connect communications ground on subsequent MForces.
Failure to follow these instructions may result in damage to system components!

⚠ CAUTION
HOT PLUGGING!
Do not connect or disconnect communications while the device is in a powered state.
Failure to follow these instructions may result in damage to system components!

4.2.1 P2 — 10-pin pressure-fit IDC style connector

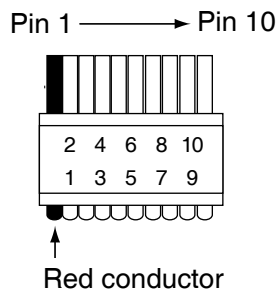

Pin #	Function	Description
1	TX +	Transmit plus
2	TX -	Transmit minus
3	RX +	Receive plus
4	RX -	Receive minus
5	Aux-Logic	Auxiliary logic maintains power to the logic circuitry in the absence of motor power. +12 to +24 VDC input
6	RX +	Receive plus
7	RX -	Receive minus
8	TX -	Transmit minus
9	TX +	Transmit plus
10	Comm GND	Communications ground only. Do not ground aux-logic to this pin.

Table 4.1 Communications connections, P2 - 10-pin IDC

Connectivity accessories

- Mating connector kit CK-01 (contains 5 connector shells, ribbon cable not included)
- Communications converter cable (10'/3.0 m) MD-CC400-001

4.2.2 P2 — 10-pin friction lock wire crimp

..... Use to connect second device

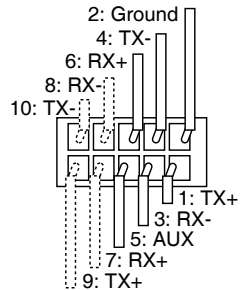

Pin #	Function	Description
1	TX +	Transmit plus
2	Comm GND	Communications ground only. Do not ground aux-logic to this pin.
3	RX -	Receive minus
4	TX -	Transmit minus
5	Aux-Logic	Auxiliary logic maintains power to the logic circuitry in the absence of motor power. +12 to +24 VDC input
6	RX +	Receive plus
7	RX +	Receive plus
8	RX -	Receive minus
9	TX +	Transmit plus
10	TX -	Transmit minus

Table 4.2 P2 communications, 10-pin locking wire crimp

Connectivity accessories

Mating connector kit CK-02
(contains 5 connector shells, ribbon cable not included)

Communications converter cable (10'/3.0 m) MD-CC402-001

4.3 Interfacing CANopen communications

4.3.1 P2 — 9-pin d-sub connector (female)

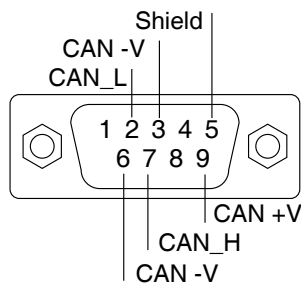

Pin #	Function	Description
1	N/C	Not connected
2	CAN low	CAN_L bus line (low dominant)
3	CAN -V	CAN communications ground
4	N/C	Not connected
5	Shield	Optional CAN shield
6	CAN -V	Optional ground
7	CAN high	CAN_H bus line (high dominant)
8	N/C	Not connected
9	CAN +V	+7 to +30 VDC power supply

Table 4.3 CANopen communications, P2: 9-pin D-sub female (DB-9F)

Connectivity accessories

Communications converter cable MD-CC500-000

4.4 Interfacing DC power

See part 1 of this document, section 3, for recommended power cable configurations.

⚠ CAUTION

OVER VOLTAGE

The DC voltage range for the MForce23Plus is +12 to +60 VDC. Ensure that motor back EMF is factored into your power supply size calculations.

Allow 3.0 A maximum power supply output current per MForce in the system. Actual power supply current will depend on voltage and load.

Failure to follow these instructions can result in equipment damage.

4.4.1 Recommended power supply characteristics

Voltage range	+12 to +75 VDC
Type	Unregulated linear
Ripple	± 5%
Output current	4.0 A (per MForce PowerDrive)

Table 4.4 Recommended power supply specifications

4.4.2 Recommended wire gauge

Cable Length: Feet (meters)	10 (3.0)	25 (7.6)	50 (15.2)	75 (22.9)	100 (30.5)
Amps Peak	Minimum AWG				
1 Amp Peak	20	20	18	18	18
2 Amps Peak	20	18	16	14	14
3 Amps Peak	18	16	14	12	12
4 Amps Peak	16	14	12	12	12

Table 4.51 Recommended power supply wire gauge

4.4.3 P1 — 12' (30.5 cm) flying leads interface

Wire Color	
Red	Motor power supply
Black	Power ground

Table 4.6 Power and ground connections, flying leads

4.4.4 P3 — 2-pin locking wire crimp interface

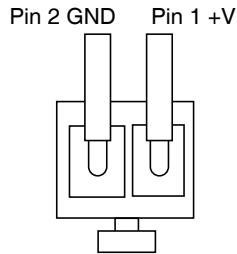

Pin #	Signal	Novanta IMS cable wire colors
		PD02-3400-FL3
1	+12 to +75 VDC supply	Red
2	Power ground	Black

Table 4.7 Power and ground connections, 12-pin locking wire crimp

Connectivity accessories

Mating connector kit CK-05
(contains 5 connector shells and the appropriate quantity of pins to make 5 cables)

Prototype development cable (10'/3.0 m)..... PD02-3400-FL3

Manufacturer (Molex) part numbers

Connector shell..... 51067-0200

Pins..... 50217-9101

4.4.5 Power Interface using Drive Protection Module DPM75

The DPM75 Drive Protection Module will limit surge currents for one (1) MForce PowerDrive at 75 VDC to allow switching DC Power.

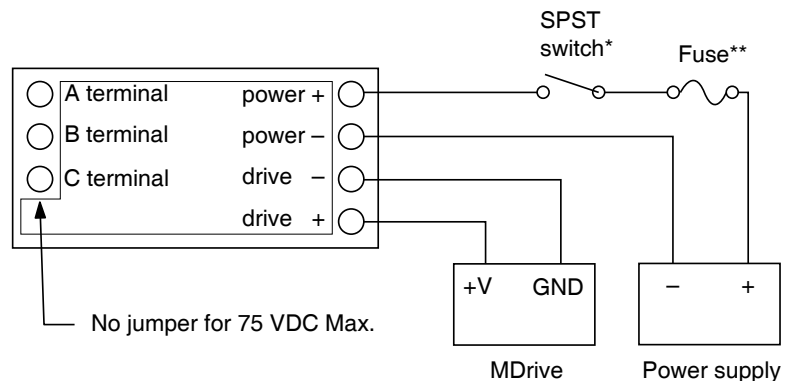

* Do not switch negative side of supply

**Fuse = 6.3 Amp slow blow (recommended: Bussman S505-6.3A or Littelfuse 215006.3). The fuse is optional.

Figure 4.2 DPM75 Drive Protection Module

4.5 Interfacing I/O

See part 1 of this document, section 4, for I/O interface configurations and methods.

 CAUTION
<p>ELECTRICAL OVERSTRESS</p> <p>The general purpose I/O is tolerant to +24 VDC. The following listed I/O point is TTL level and only tolerant to +5 VDC:</p> <ol style="list-style-type: none"> 1) Capture/Trip 2) Step/Direction 3) Remote encoder inputs <p>Do not exceed +5 VDC on these points.</p> <p>Failure to follow these instructions can result in equipment damage.</p>

4.5.1 P1 — 12' (30.5 cm) flying leads interface

<i>Wire Color</i>	<i>Signal</i>
White/yellow	General purpose I/O 1
White/orange	General purpose I/O 2
White/violet	General purpose I/O 3
White/blue	General purpose I/O 4
Green	Analog input

Table 4.8 I/O connections, flying leads

4.5.2 P1 — 14-pin locking wire crimp interface (expanded I/O)

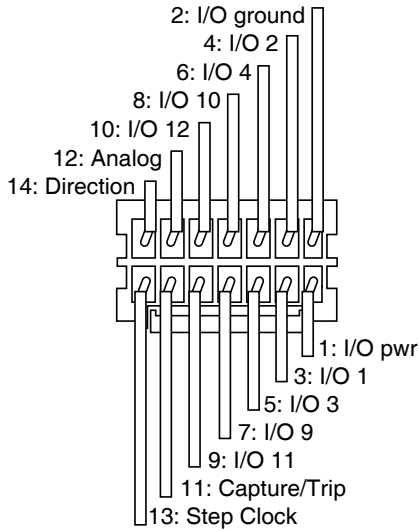

Pin Numbers	Signal	Prototype development cable wire colors (twisted pairs)
1	I/O power	Red
2	I/O ground	Black
3	General purpose I/O 1	Orange
4	General purpose I/O 2	Black
5	General purpose I/O 3	Brown
6	General purpose I/O 4	Black
7	General purpose I/O 9	Yellow
8	General purpose I/O 10	Black
9	General purpose I/O 11	Blue
10	General purpose I/O 12	Black
11	Capture output/trip input	Green
12	Analog input	Black
13	Step clock I/O	White
14	Direction clock I/O	Black

Table 4.9 I/O connections, 16-pin locking wire crimp

Connectivity accessories

Mating connector kit CK-09
(contains 5 connector shells and the appropriate quantity of pins to make 5 cables)

Prototype development cable (10'/3.0 m)..... PD14-2334-FL3

Manufacturer (JST) part numbers

Connector shell..... PADP-14V-1-S

Pins..... SPH-001T0.5L

4.5.3 P1 — 20-pin locking wire crimp interface (remote encoder)

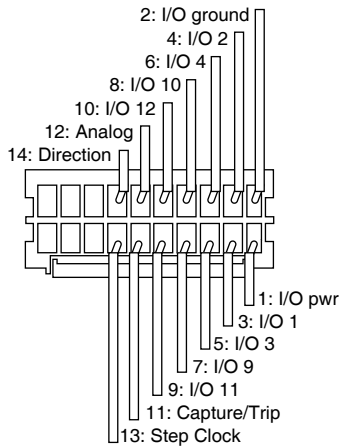

I/O Connections

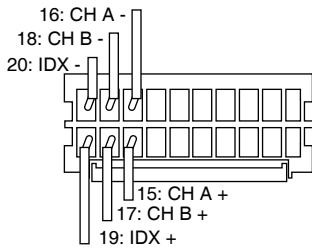

Remote Encoder Connections

Pin Numbers	Signal	Prototype development cable wire colors (twisted pairs)
I/O: Cable 1		
1	I/O power	Red
2	I/O ground	Black
3	General purpose I/O 1	Orange
4	General purpose I/O 2	Black
5	General purpose I/O 3	Brown
6	General purpose I/O 4	Black
7	General purpose I/O 9	Yellow
8	General purpose I/O 10	Black
9	General purpose I/O 11	Blue
10	General purpose I/O 12	Black
11	Capture output/trip input	Green
12	Analog input	Black
13	Step clock I/O	White
14	Direction clock I/O	Black
Remote Encoder: Cable 2		
15	Channel A +	White/blue
16	Channel A -	Blue/White
17	Channel B +	White/orange
18	Channel B -	Orange/White
19	Index +	White/green
20	Index -	Green/white

Table 4.20 I/O and remote encoder connections, 16-pin locking wire crimp

Connectivity accessories

Mating connector kit CK11 (contains 5 connector shells and the appropriate quantity of pins to make 5 cables)

Prototype development cable (10'/3.0 m)..... PD20-3400-FL3

Manufacturer (JST) part numbers

Connector shell..... PADP-20V-1-S

Pins..... SPH-001T0.5L

4.6 Interfacing the motor

See part 1 of this document, section 5, for motor selection and interface configurations.

4.6.1 P1 — 4-pin locking wire crimp interface

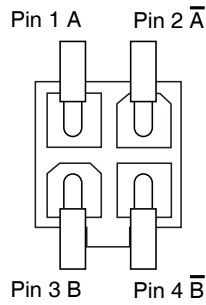

<i>Pin Numbers</i>	<i>Signal</i>	<i>Prototype development cable wire colors (twisted pairs are labeled)</i>
1	Phase A output	Black (pair 2)
2	Phase A return	White (pair 2)
3	Phase B output	Black (pair 1)
4	Phase B return	White (pair 1)

Table 4.11 Motor connections, 4-pin locking wire crimp

Connectivity accessories

Mating connector kitCK-07
(contains 5 connector shells and the appropriate quantity of pins to make 5 cables)

Prototype development cable (10'/3.0 m)..... PD04-3400-FL3

Manufacturer (Molex) part numbers

Connector shell.....39-01-2045

Pins.....44476-3112

4.7 Connectivity accessory details

4.7.1 Communications converter cables

USB to 10-pin IDC connector P2
P/N: MD-CC400-001

Electrically isolated in-line USB to RS-422/485 converter pre-wired with mating connector to conveniently program and set configuration parameters

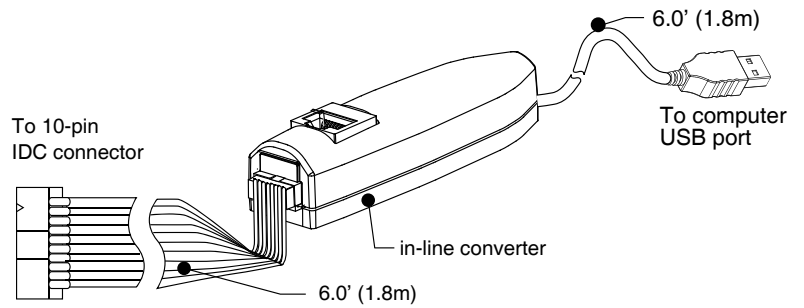

Figure 4.3 MD-CC400-000 communications converter cable

USB to 10-pin wire crimp connector P2
P/N: MD-CC402-001

Electrically isolated in-line USB to RS-422/485 converter pre-wired with mating connector to conveniently program and set configuration parameters

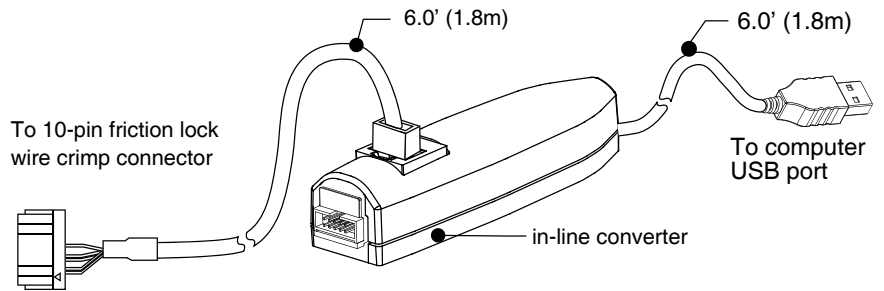

Figure 4.4 MD-CC402-001 communications converter cable

CANopen communications converter cable
MD-CC500-000

See Part 1, Section 6 of this document for CANopen connectivity instructions and MD-CC500-000 details.

4.7.2 Prototype development cables

Flying leads to 10-pin wire crimp connector
 P2 -P/N: PD10-1434-FL3

Used in conjunction with the MD-CC402-001 communications converter cable to facilitate multi-drop RS-422/485 communications.

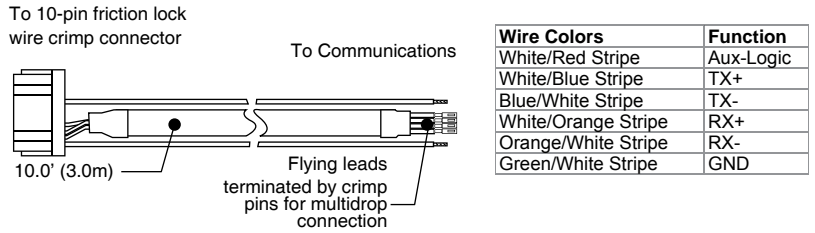

Note: If not using Aux-Logic
 Remove Wire (White/Red Stripe)

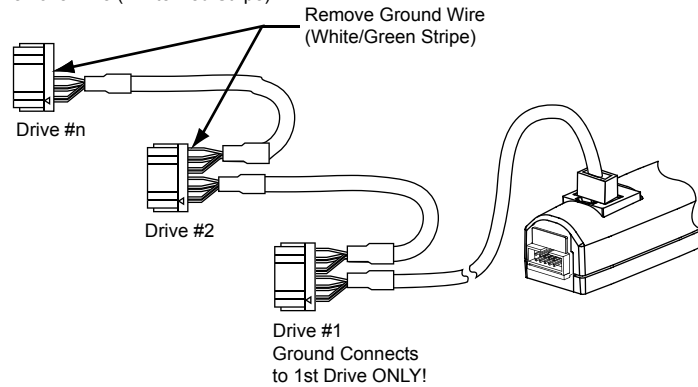

Figure 4.3 Multi-drop communications using the PD10-1434-FL3

Procedure

- 1) Remove ground wire (unless this is the first system MForce, green/white stripe)
- 2) Remove aux-logic (if not used, red/white stripe)
- 3) Connect pre-crimped flying leads as shown in Figure 5.7 below

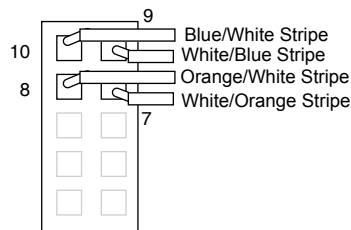
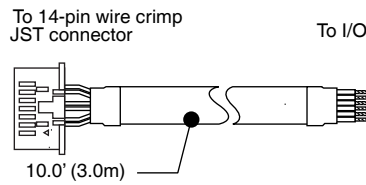

Figure 4.4 Wiring a second PD10-1434-FL3 into the 10-pin wire crimp connector.

Flying leads to 14-pin locking wire crimp connector P1 -P/N: PD14-2334-FL3

The PD14-2334-FL3 prototype development cable is used to rapidly interface the MForce PowerDrive to the users controller. This 10' (3.0 m) cable consists of a 14-pin locking wire crimp connector to plug directly into the MForce P1 connector with flying leads on the opposite end to interface to I/O devices.



Pair	Wire Colors	Function	Encoder Function
1	Black	Direction	IDX+
	White	Step Clock	IDX-
2	Black	Analog In	Analog In
	Green	Capt/Trip	Capt/Trip
3	Black	I/O12	CH B-
	Blue	I/O11	CH B+
4	Black	I/O10	CH A-
	Yellow	I/O9	CH A +
5	Black	I/O4	I/O4
	Brown	I/O3	I/O3
6	Black	I/O2	I/O2
	Orange	I/O1	I/O1
7	Black	I/O Ground	I/O Ground
	Red	I/O Power	I/O Power

Figure 4.5 Prototype development cable PD14-2334-FL3

Flying leads to 20-pin locking wire crimp connector P1 -P/N: PD20-3400-FL3

The PD20-3400-FL3 prototype development cable is used to rapidly interface the MForce PowerDrive to the users controller. This 10' (3.0 m) cable consists of a 20-pin locking wire crimp connector to plug directly into the MForce P1 connector with flying leads on the opposite end to interface to I/O devices.

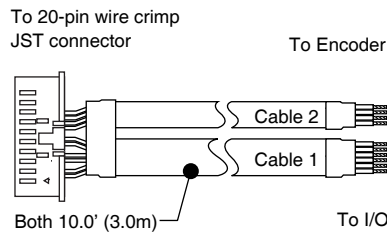

Pair	Wire Colors	Function
Cable 1		
1	Black	Direction
	White	Step Clock
2	Black	Analog In
	Green	Capt/Trip
3	Black	I/O12
	Blue	I/O11
4	Black	I/O10
	Yellow	I/O9
5	Black	I/O4
	Brown	I/O3
6	Black	I/O2
	Orange	I/O1
7	Black	I/O Ground
	Red	I/O Power

Pair	Wire Colors	Function
Cable 2		
1	White w/Blue Stripe	CH A+
	Blue w/White Stripe	CH A-
	White w/Orange Stripe	CH B+
2	Orange w/White Stripe	CH B-
	White w/Green Stripe	IDX+
3	Green w/White Stripe	IDX-

Figure 4.6 Prototype development cable PD20-3400-FL3

Flying leads to 2-pin locking wire crimp connector P3 -P/N: PD02-3400-FL3

The PD02-3400-FL3 prototype development cable is used to rapidly interface the MForce PowerDrive to the users DC power supply. This 10' (3.0 m) cable consists of a 2-pin locking wire crimp connector to plug directly into the MForce P3 connector with flying leads on the opposite end to interface to DC power.

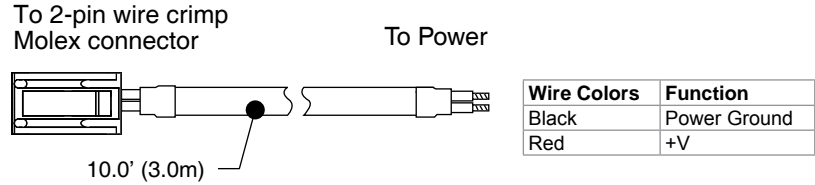

Figure 4.7 Prototype development cable PD02-3400-FL3

Flying leads to 4-pin locking wire crimp connector P4-P/N: PD04-3400-FL

Description: Pre-wired mating connector interfaces to the 4-pin wire crimp connector, with flying leads other end, for quick test/development.

Function: Motor Interface.

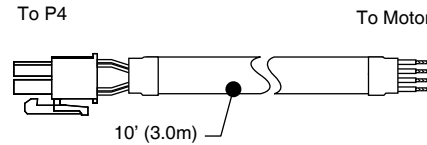

Figure 4.8 Prototype development cable PD04-3400-FL3

4.8 Mating connector kits

Use to build your own cables. Kit contains 5 mating shells with pins. Cable not supplied. Manufacturer's crimp tool recommended.

Mates to connector:

- P2 10-pin pressure-fit IDC CK-01
- P2 10-pin wire crimp CK-02
- P1 14-pin wire crimp CK-09
- P3 2-pin wire crimp CK-05
- P4 4-pin wire crimp CK-07

WARRANTY

TWENTY-FOUR (24) MONTH LIMITED WARRANTY

Novanta IMS warrants only to the purchaser of the Product from Novanta IMS (the "Customer") that the product purchased from Novanta IMS (the "Product") will be free from defects in materials and workmanship under the normal use and service for which the Product was designed for a period of 24 months from the date of purchase of the Product by the Customer. Customer's exclusive remedy under this Limited Warranty shall be the repair or replacement, at Company's sole option, of the Product, or any part of the Product, determined by Novanta IMS to be defective. In order to exercise its warranty rights, Customer must notify Company in accordance with the instructions described under the heading "Obtaining Warranty Service".

NOTE: MDrive Motion Control electronics are not removable from the motor in the field. The entire unit must be returned to the factory for repair.

This Limited Warranty does not extend to any Product damaged by reason of alteration, accident, abuse, neglect or misuse or improper or inadequate handling; improper or inadequate wiring utilized or installed in connection with the Product; installation, operation or use of the Product not made in strict accordance with the specifications and written instructions provided by Novanta IMS; use of the Product for any purpose other than those for which it was designed; ordinary wear and tear; disasters or Acts of God; unauthorized attachments, alterations or modifications to the Product; the misuse or failure of any item or equipment connected to the Product not supplied by Novanta IMS; improper maintenance or repair of the Product; or any other reason or event not caused by Novanta IMS.

NOVANTA IMS HEREBY DISCLAIMS ALL OTHER WARRANTIES, WHETHER WRITTEN OR ORAL, EXPRESS OR IMPLIED BY LAW OR OTHERWISE, INCLUDING WITHOUT LIMITATION, ANY WARRANTIES OF MERCHANTABILITY OR FITNESS FOR ANY PARTICULAR PURPOSE. CUSTOMER'S SOLE REMEDY FOR ANY DEFECTIVE PRODUCT WILL BE AS STATED ABOVE, AND IN NO EVENT WILL NOVANTA IMS BE LIABLE FOR INCIDENTAL, CONSEQUENTIAL, SPECIAL OR INDIRECT DAMAGES IN CONNECTION WITH THE PRODUCT.

This Limited Warranty shall be void if the Customer fails to comply with all of the terms set forth in this Limited Warranty. This Limited Warranty is the sole warranty offered by Novanta IMS with respect to the Product. Novanta IMS does not assume any other liability in connection with the sale of the Product. No representative of Novanta IMS is authorized to extend this Limited Warranty or to change it in any manner whatsoever. No warranty applies to any party other than the original Customer.

Novanta IMS and its directors, officers, employees, subsidiaries and affiliates shall not be liable for any damages arising from any loss of equipment, loss or distortion of data, loss of time, loss or destruction of software or other property, loss of production or profits, overhead costs, claims of third parties, labor or materials, penalties or liquidated damages or punitive damages, whatsoever, whether based upon breach of warranty, breach of contract, negligence, strict liability or any other legal theory, or other losses or expenses incurred by the Customer or any third party.

OBTAINING WARRANTY SERVICE

If the Product was purchased from a Novanta IMS Distributor, please contact that Distributor to obtain a Returned Material Authorization (RMA). If the Product was purchased directly from Novanta IMS, please contact Customer Service at custservicegroup@novanta.com or 860-295-6102 (Eastern Time Zone).

Customer shall prepay shipping charges for Products returned to Novanta IMS for warranty service and Novanta IMS shall pay for return of Products to Customer by ground transportation. However, Customer shall pay all shipping charges, duties and taxes for Products returned to Novanta IMS from outside the United States.

Novanta IMS
370 N. Main Street
Marlborough, CT 06447
860-295-6102
www.novanataims.com

© Novanta IMS All Rights Reserved. *Product Disclaimer and most recent product information at www.novantaims.com*

REV060923

