

REV.	Description	Initiator	Date
01P	INITIAL ISSUE	DSS	06/05/2025

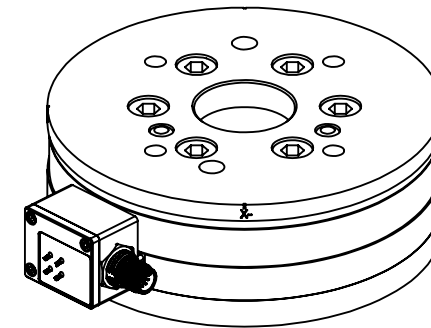
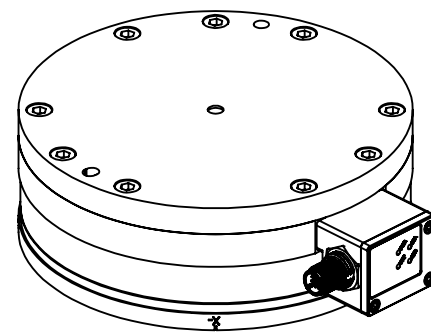
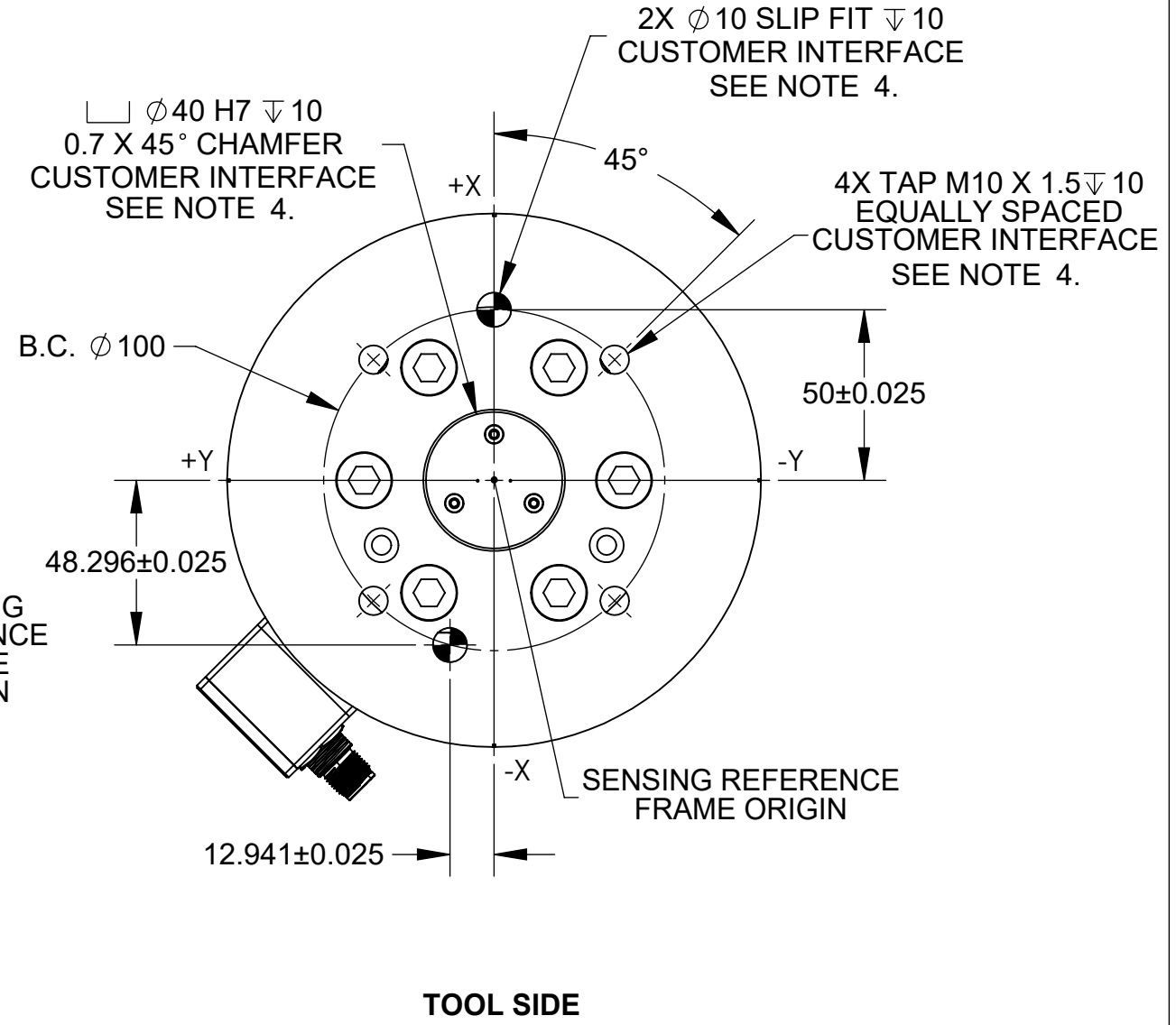
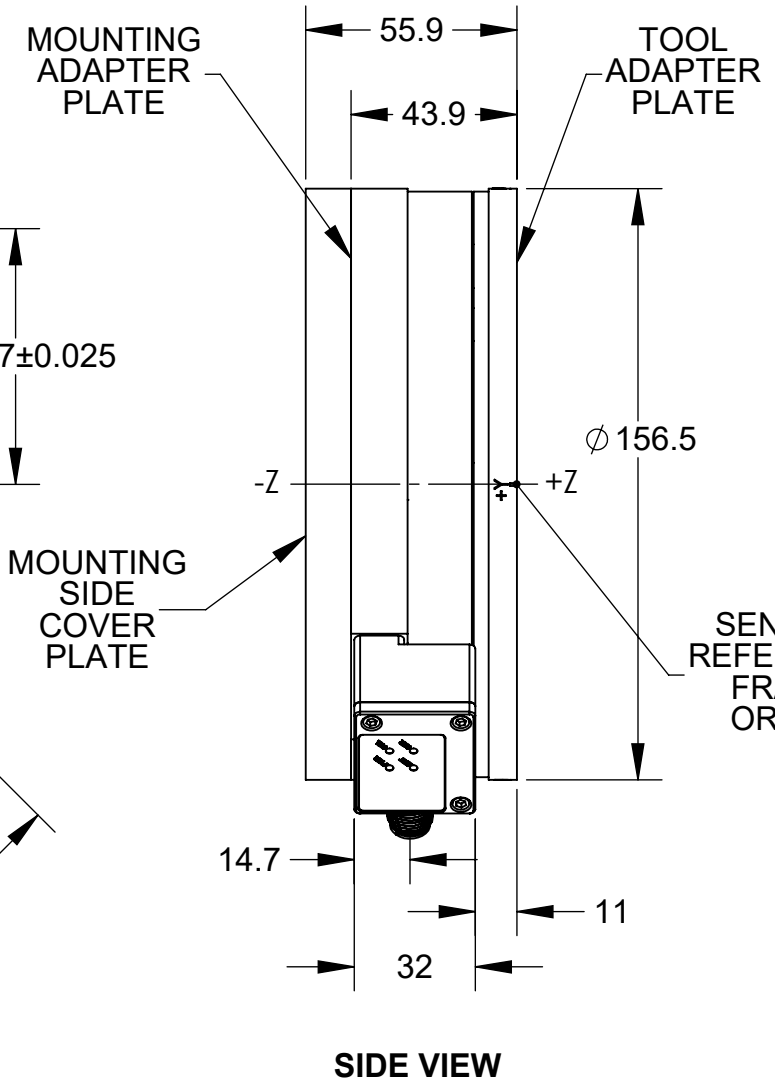
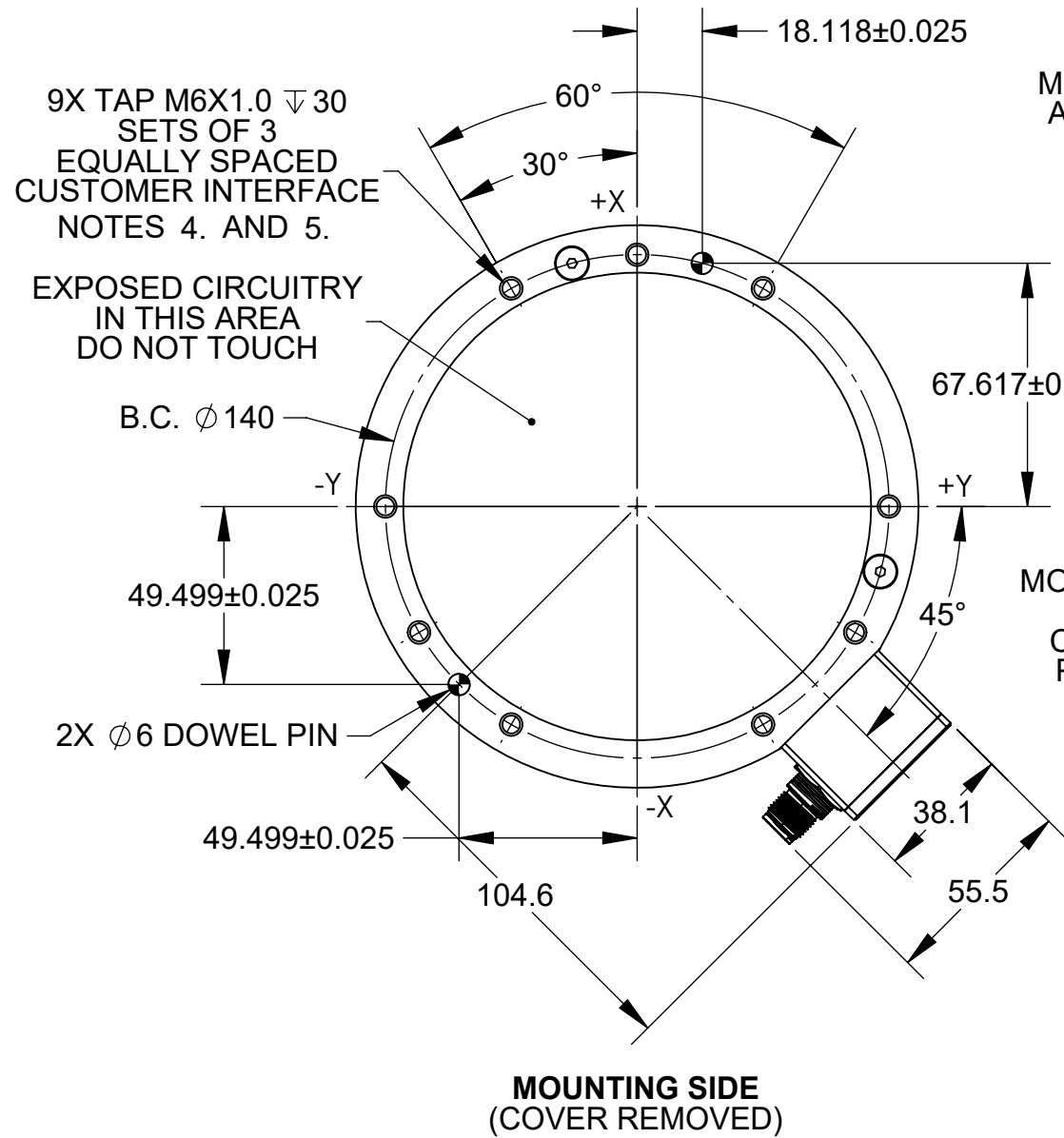

- NOTES:
- MATERIAL: STAINLESS STEEL AND ALUMINUM
  - SENSING REFERENCE FRAME ORIGIN AT SURFACE CENTER OF TOOL ADAPTER.
  - DO NOT TOUCH INTERNAL ELECTRONICS OR INSTRUMENTATION. THIS COULD DAMAGE THE TRANSDUCER AND WILL VOID THE WARRANTY.**
  - DO NOT EXCEED INTERFACE DEPTH, MAY CAUSE DAMAGE.**
  - NO THREADS PRESENT FIRST 15MM OF INTERFACE
  - ALL NON-TOLERANCED DIMENSIONS ARE FOR REFERENCE ONLY.
  - REMOVE MOUNTING SIDE COVER PLATE TO MOUNT SENSOR TO INTERFACE PLATE.

NOTES: UNLESS OTHERWISE SPECIFIED.

DO NOT SCALE DRAWING. ALL DIMENSIONS ARE IN MILLIMETERS.

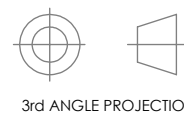

1031 Goodworth Drive, Apex, NC 27539, USA  
 Tel: +1.919.772.0115 www.ati-ia.com  
 Fax: +1.919.772.8259 ISO 9001 Registered Company

PROPERTY OF ATI INDUSTRIAL AUTOMATION, INC. NOT TO BE REPRODUCED IN ANY MANNER EXCEPT ON ORDER OR WITH PRIOR WRITTEN AUTHORIZATION OF ATI.

DRAWN BY: D. Swanson 6/5/25		TITLE	
CHECKED BY: T. Dean 6/20/25		Gen3 Omega160 Customer Drawing	
PROJECT #	SHEET 1 OF 1	SCALE	SIZE
		1:2	B
DRAWING NUMBER		REVISION	
9630-05-0057		01P	